

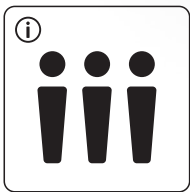

DISREGARD OTHER FRAME MANUAL

FULL ASSEMBLY PG.14
RETROFIT ASSEMBLY PG.50



MINIMUM OF THREE PEOPLE REQUIRED TO ASSEMBLE THIS PRODUCT.

ATTENTION!

SAFETY INFORMATION, INSTALLATION, CARE AND MAINTENANCE INSTRUCTIONS. READ PRIOR TO ASSEMBLING AND USING THE PRODUCT.

Vuly cares about safety.
Adult supervision is required at all times whilst equipment is in use.

If you have any feedback regarding our instructions, feel free to email instructions@vulyplay.com so that we can continue to improve.



Scan this QR code
or visit vulyplay.us/install for
step-by-step video instructions



Disclaimer

The following Conditions of Sale will apply to, and bind the purchaser of, any Vuly USA Operations Corp (3666901) product.

NOTICE TO USER:

Please read this agreement carefully before purchase or assembly. By purchasing, opening and assembling this product you acknowledge that you have read this agreement, understand it and agree to be bound by its conditions. If you are making a purchase on behalf of another person, you agree that you are making the purchase as their agent.

LEGAL RIGHTS – PLEASE READ:

EXCLUSION OF LIABILITY – WAIVER OF RIGHT TO SUE – YOUR ASSUMPTION OF RISK – THESE CONDITIONS AFFECT YOUR LEGAL RIGHTS.

Vuly USA Operations Corp. (3666901) (“Vuly”), as supplier of trampolines and accessories (“Products”), sells all Products subject to the following conditions:

1. To the maximum extent permitted by the law, Vuly, its employees, directors and agents will not be liable to the customer, their dependents or legal representatives for damage to property, personal injury or death suffered by the customer because the Product was not manufactured or supplied with due care and skill, the Product is not reasonably fit for its purpose or because of negligence, breach of contract, breach of statute or breach of statutory duty by Vuly.
2. Vuly, its employees, directors and agents are not liable to the customer, their dependents or legal representatives for personal injury or death suffered by the customer because the Product was not:
 - a. installed in accordance with the Vuly instruction manual. It is the customer’s responsibility to check all boxes to confirm that all components are included and in the correct condition before assembly.
 - b. installed with due care and skill, by a the customer or a third party assembly service; and
 - c. in the same condition as when the Product was supplied, due to wear and tear – including, but not limited to, weather damage, deterioration of the net, spring stretch, UV deterioration or rust.
1. The customer acknowledges that using the Product can be dangerous, with inherent risks and hazards. As a consequence, personal injury or death may occur. The customer assumes and accepts all such risks, and hereby – to the full extent permitted by law – waives the right of action against, and fully releases Vuly for, loss, damages, personal injury or death in any way caused by, or relating to, the customer’s participation in such activities.

This includes – without limitation – liability for any negligent or tortuous acts or omission, breach of duty, breach of contract or breach of statutory duty on the part of Vuly, its office bearers, directors, employees or agents.

WARNING!

To reduce the risk of injury while using the system, enforce the following:

- Minimum user age – 6 years.
- Maximum number of users – 4.
- Adult assembly required.
- Adult supervision required at all times.
- Ensure that the system is secured with anchors or bolts before use.
- Exercise caution at heights. Maximum fall height is 7.22ft.
- Three adults required for assembly.
- Strong winds and wild weather can cause products to lift up and move, to avoid danger please secure your product

You will need these for assembly:

- Ladder
- Rubber mallet
- Tape measure or ruler

Vuly Play

95 Ingleston Rd, Brisbane QLD 4154

AU: 1300 667 514

US: 1-833-333-8888

www.vulyplay.us



Contents

Read and follow all instructions in this manual before using your system, and do not use it in any way that is not described in this manual.

Responsibility rests with the owner and supervisors of the product to make sure that all users are aware of the practices specified in this manual.

1.0. Care and Maintenance.....	2
1.1. General care.....	2
1.2. Rust and corrosion	2
1.3. Textile deterioration.....	2
1.4. Weather care.....	2
2.0. Usage and behaviour	3
2.1. Safe use information	3
2.2. Safe use instructions.....	3
3.0. Pre-assembly	4
3.1. Size Reference.....	4
3.2. Tips & Tricks	4
3.3. Parts and components	7
4.0. Assembly Instructions.....	14
4.1. Full Assembly Instructions.....	14
4.2. Retrofit Assembly Instructions	50
5.0. Product registration	79
6.0. Half-price replacement parts.....	79
7.0. Warranty.....	79
7.1. Warranty periods	79
7.2. Inclusions	79
7.3. Exclusions	79
7.4. Warranty Claims	80
7.5. Consumer Law.....	81
8.0. Missing parts	81



1.0. Care and Maintenance

Improper maintenance or lack of care can lead to your system deteriorating earlier than expected and causing injury. Please follow these instructions to ensure that your product lasts for as long as possible.

1.1. General care

- Retain this Manual.
- Inspect before and after each use.
- Replace any worn, deteriorated, defective or missing parts immediately and only through Vuly.
- Tighten all hardware, including elements that secure the system to the ground.
- Keep away objects that could damage textile components.
- Ensure that moving steel components remain well lubricated.
- Use only parts and accessories recommended by Vuly.

1.2. Rust and corrosion

- Be aware of, and check, areas that are particularly prone to rusting:
 - Places where water is easily trapped.
 - Hollow sections of steel (which can appear in good condition on the outside, while hiding rust on the inside).
 - Sections where steel components join together.
- Inspect the inside of all tubes every 6 months – as well as after rain – and remove any water from the inside surfaces.
- Use general-purpose grease on steel connection areas.
- Avoid cleaning steel components excessively; it may reduce the effectiveness of their protective coatings.

1.3. Textile deterioration

- Remove textile parts, and store them – in their original packaging – in a cool, dry and dark place when the system will be unused for over 1 month. Prolonged exposure to UV sunlight can shorten the lifespan of textile materials.

1.4. Weather care

Components are susceptible to deterioration from use and environmental conditions – such as sunlight, rain, salt and heat – to varying degrees.

If your system will be unused for any extended period, disassemble it, return it to its original packaging and store it in a dry place.



RAIN: Remove any fallen debris after rain and wipe off residual water with a dry cloth.



WIND: Disconnect any accessories, and cover the frame with a storm cover.



HEAT: Cover when not in use to minimise UV damage.

COMPONENTS WILL DETERIORATE OVER TIME.

Record your date of purchase:

	/	/
---	---	---



WARNING: Strong winds and wild weather can cause products to lift up and move, to avoid danger please secure your product

2.0. Usage and behaviour

Improper maintenance or lack of care can lead to your system deteriorating earlier than expected and causing injury. Please follow these instructions to ensure that your product lasts for as long as possible.

2.1. Safe use information

- Maximum user weight: 176.3 lbs.
- User limitation: Do not exceed more than two users on one side at any time.
- Domestic and outdoor use only.
- Suitable for ages 6 and over.
- Maximum users at one time: 4
- Minimum 3 adults required for assembly.

2.2. Safe use instructions



Adult supervision is required at all times whilst equipment is in use. Vuly cares about safety.



WARNING: To reduce the risk of injury while using the system, enforce the following.

- Ensure that the system has been assembled by an adult, in accordance with the assembly instructions.
- Ensure that the system has been checked over before use, and that all attachments are secure.
- Do not use in strong wind conditions or wet weather, and keep the system secure.
- Ensure active and competent adult supervision at all times while children are using the system.
- Wear comfortable clothing, which allows full and free movement, and closed-in footwear.
- Ensure that the system has been checked over before use, and that all attachments are secure.
 - Do not wear jewellery, drawstrings, cords, loops, buckles or anything that could entangle in components and become a strangulation hazard, a contact hazard or damage the system
 - Empty pockets and hands before use
- Exercise caution at heights.
- Make sure that the areas around, underneath and above the system are clear.
- Demonstrate safe use for children before allowing them onto the system.
- Do not walk close to, in front of, behind, or between moving items.
- Do not to attach items that are not specifically designed for use with the system, such as – but not limited to – jump ropes, clothesline, pet leashes, cables and chains.
- Install the system on level ground and in a well-lit area, no less than 2 m (6 ft) from any structure or obstruction – such as a fence, garage, house, overhanging branches, laundry lines, or electrical wires.
- Ensure that your chosen surface allows the system to be firmly embedded with the included Anchor Kit or with strong bolts.
- Preference installing the system on a surface with impact-attenuating properties – such as grass. A fall onto a hard surface can result in serious injury or death to the equipment user.
- Check that you have all parts required for assembly.
- Lock nuts and bolts securely.
- Children must not use the equipment until properly installed.



3.0. Pre-assembly

3.1. Size Reference

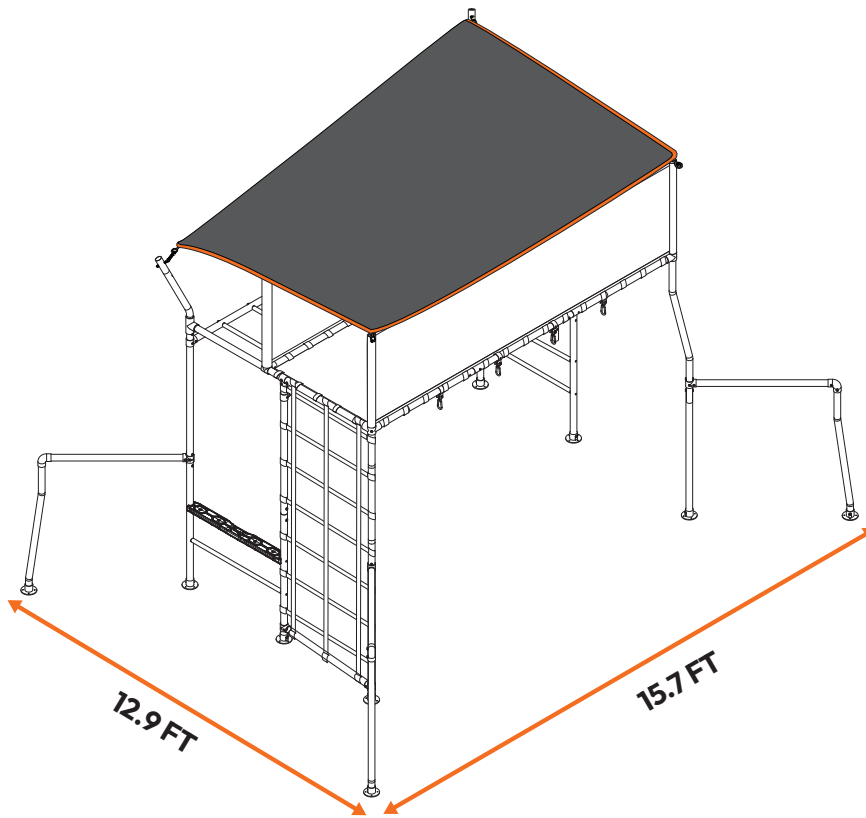

3.2. Tips & Tricks

3.2.1. Joiner Fitting

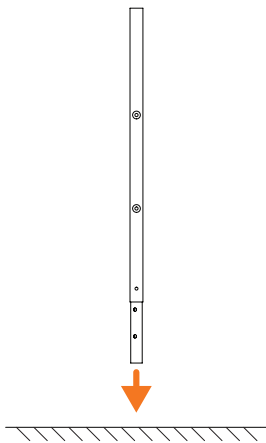

Difficulty in inserting joiners to frame tubes can be resolved by inverting the tube and tapping the internal joiner against a scrap piece of wood.

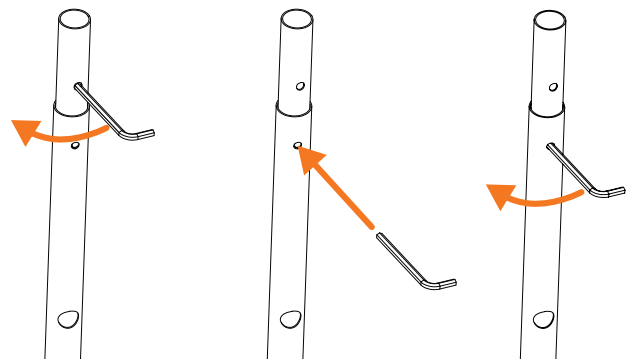

To align the joiner holes with the holes in the frame tube, take the large 6mm Allen key and insert it into the top hole in the joiner tube then twist until the holes align. If further alignment is required, remove the Allen key and place it through the holes in the joiner and the tube. Use the Allen key to lever the holes into alignment.



3.2.2. Uneven Ground

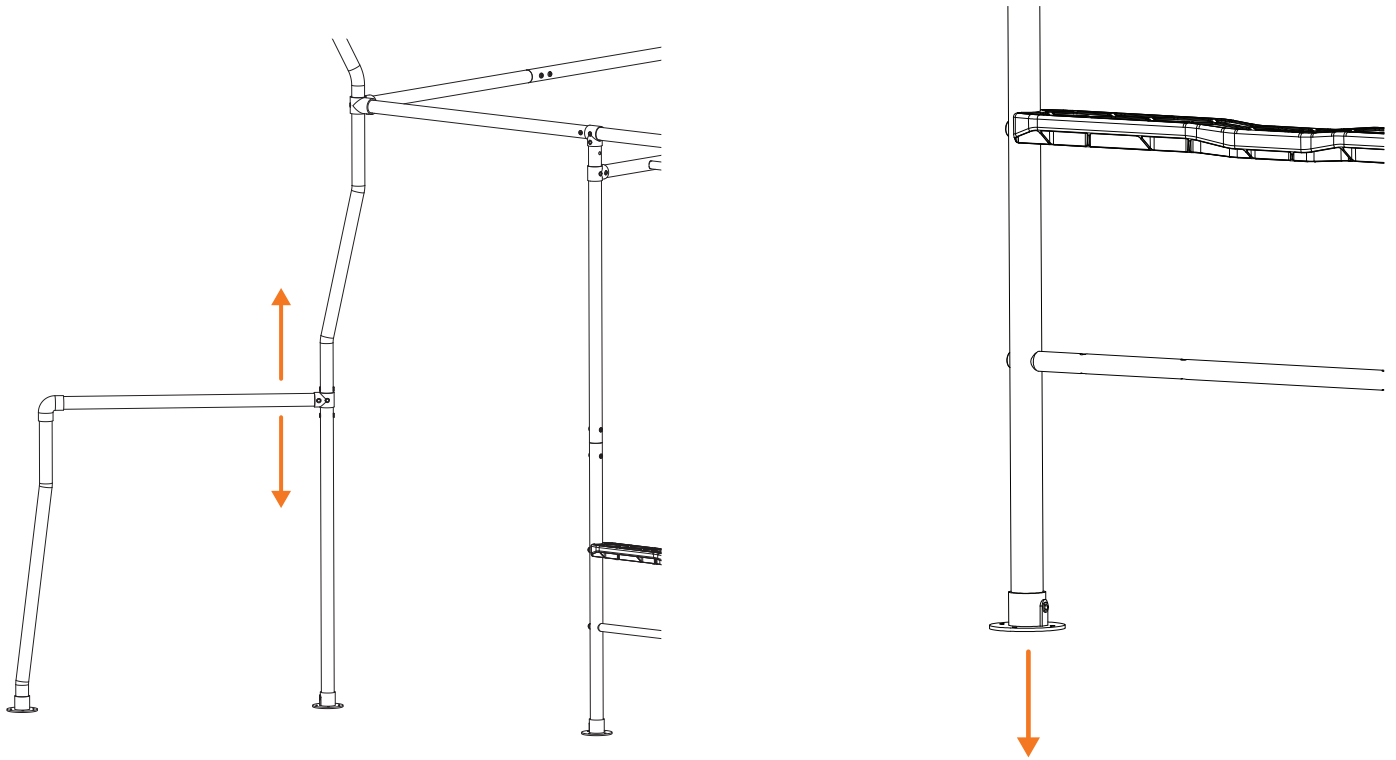

Ensure that ground at the installation location is level and clear of obstructions. Installing on an uneven surface can cause misalignment and instability.



**FULL ASSEMBLY
GO TO: PAGE 14**



**IF YOU HAVE ASSEMBLED A QUEST FRAME, GO TO:
PAGE 50**



3.3. Parts and components

BOX A

A1 x2

A2 x2

A3 x2

A4 x2

A5 x2

A6 x2

A7 x3

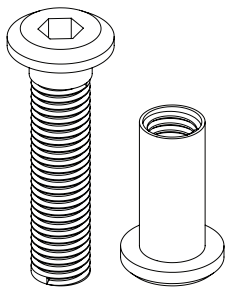

x8
A8

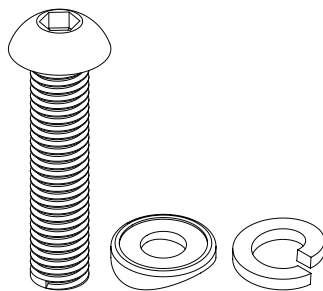

x18
A9

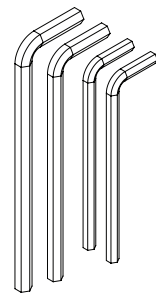

x1
A10



BOX B

B1 x4

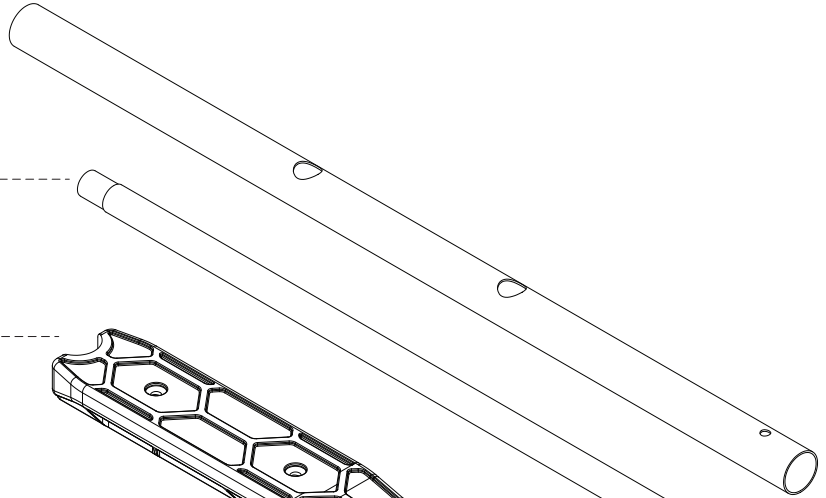

B2 x3

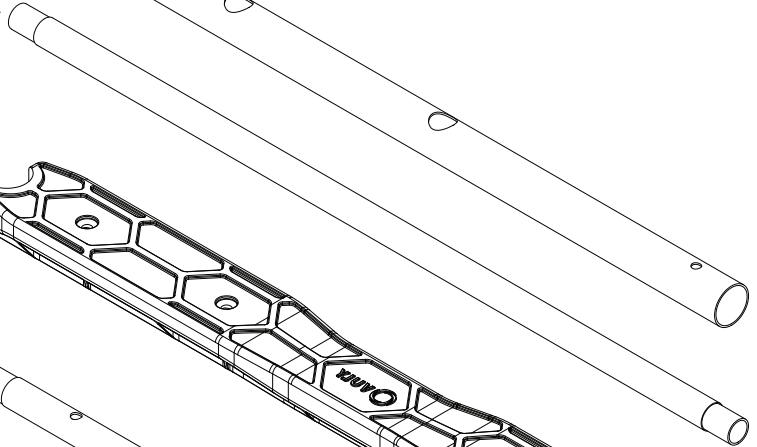

B3 x1

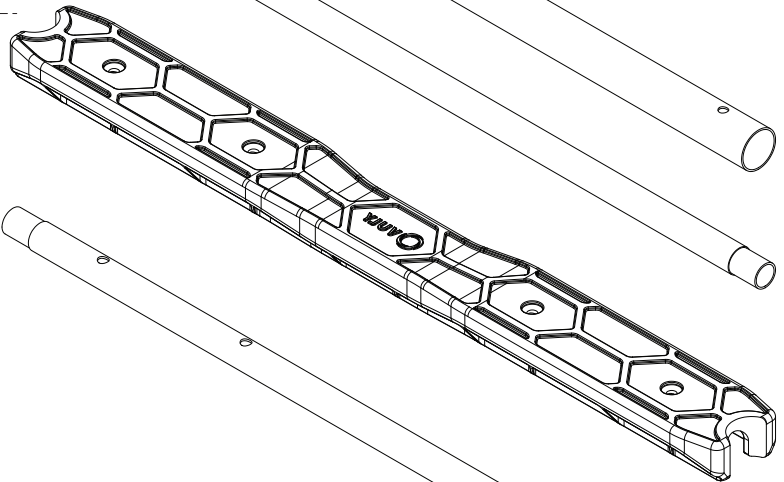

B4 x1

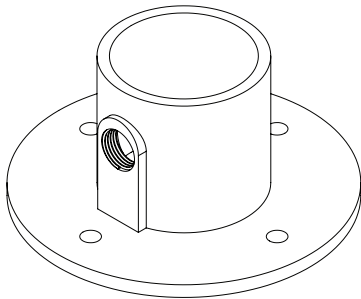
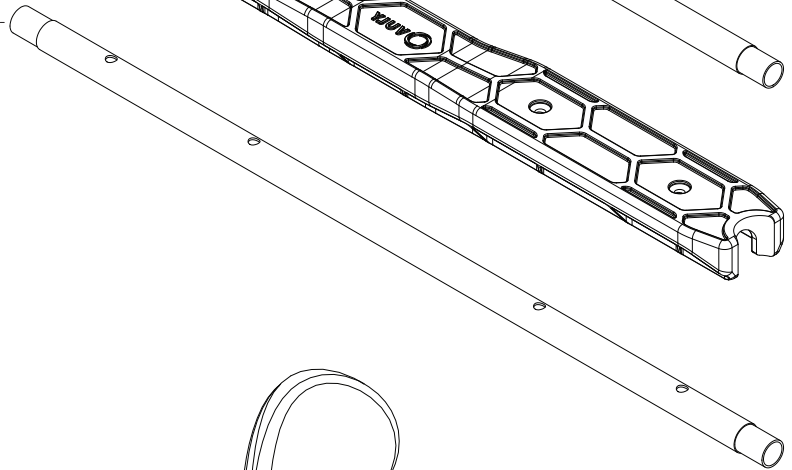

**x8
B5**

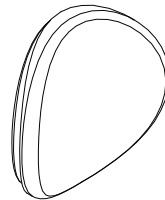

**x2
B8**

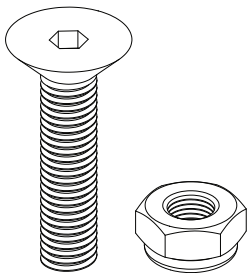

**x4
B6**

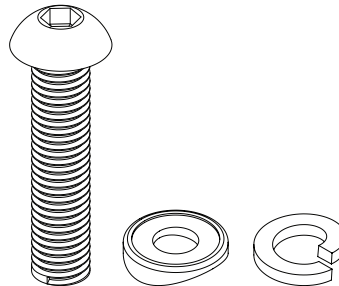

**x8
B7**



BOX C

C1 x4

C2 x4

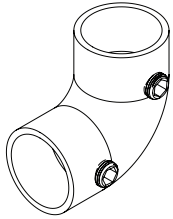

x4
C3

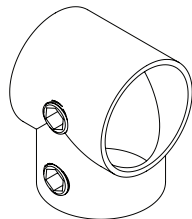

x4
C4

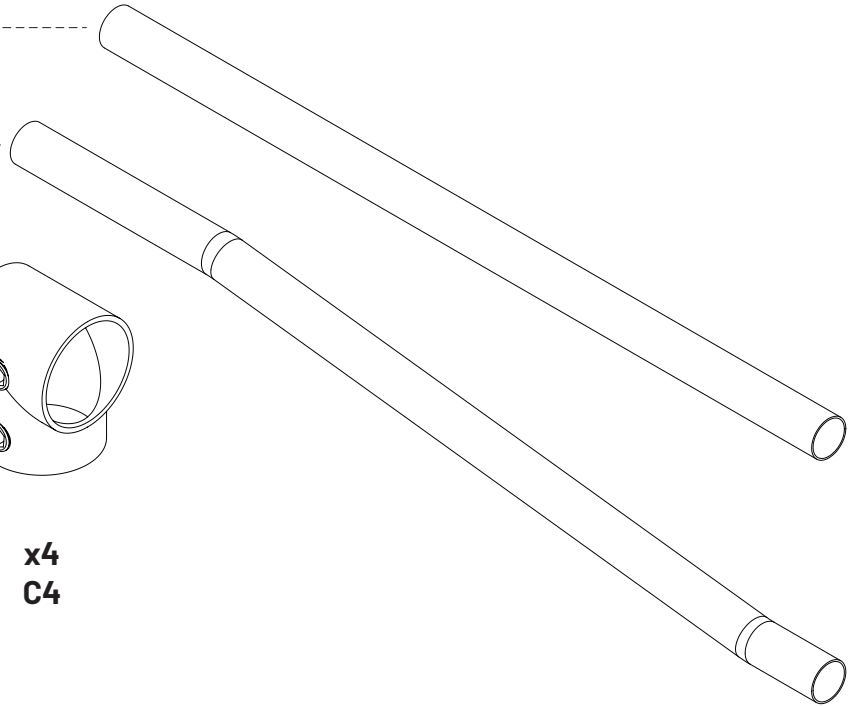

BOX E

E4 x1

E3 x1

E1 x2

E2 x1

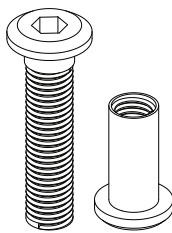

x6
E5

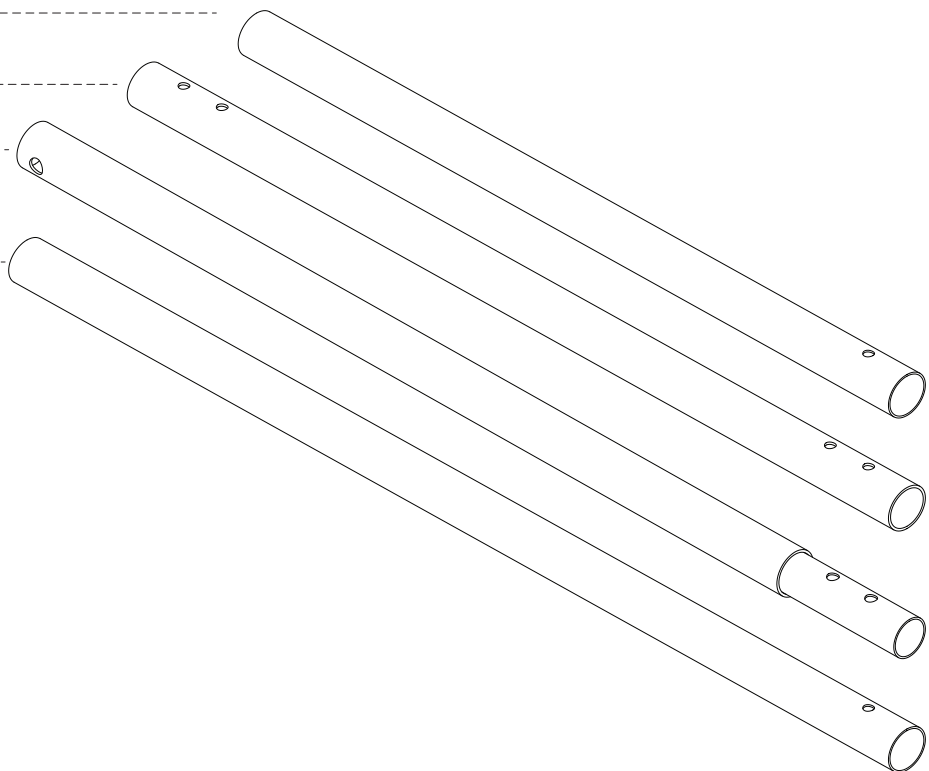

BOX F

F2 x2

F3 x2

F1 x2

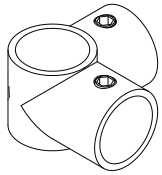

x2
F4

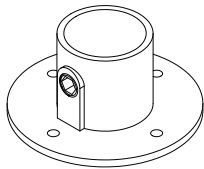

x2
F5



x7
F6

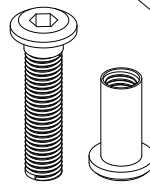

x4
F7

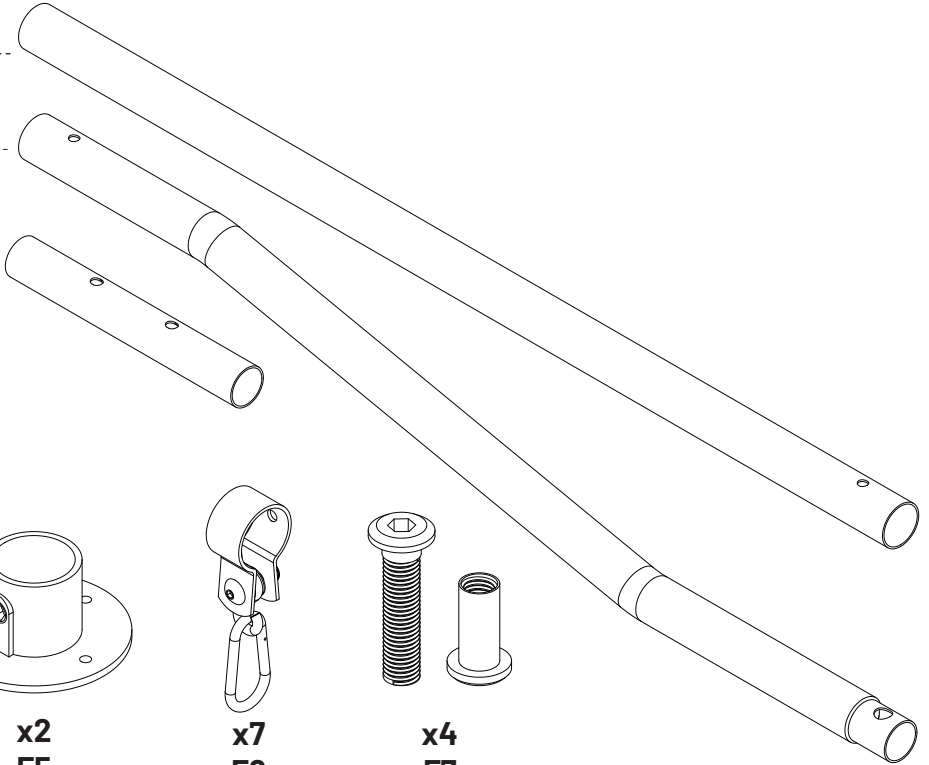

BOX G

G1 x4

G2 x2

G3 x4

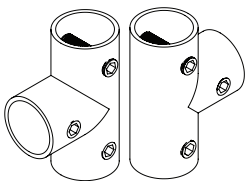

x1
G4

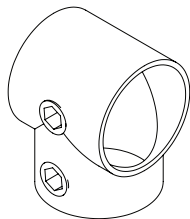

x6
G5

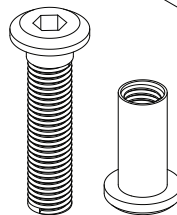

x8
G6

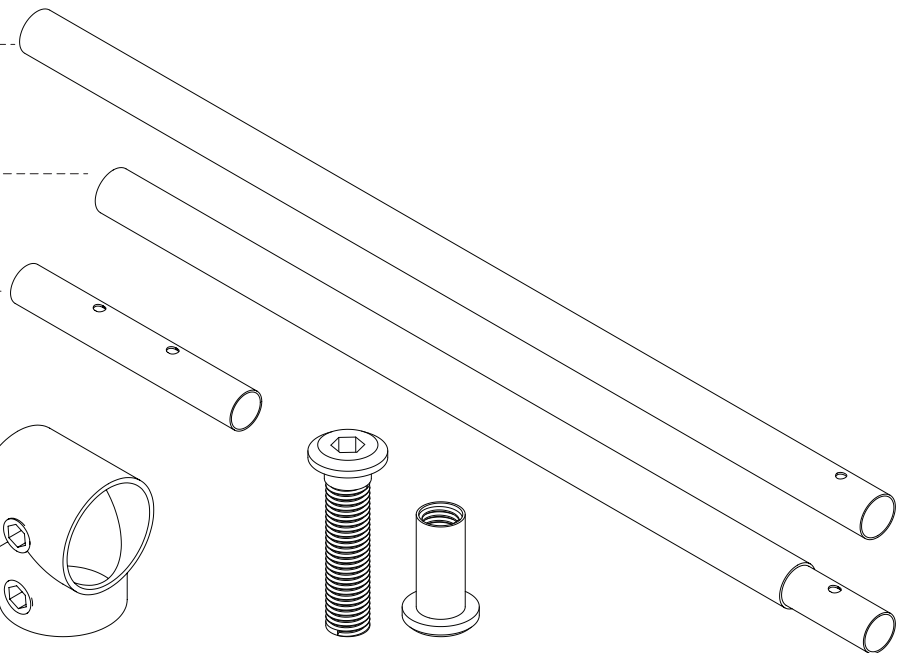

BOX SHADE COVER

L1 x1

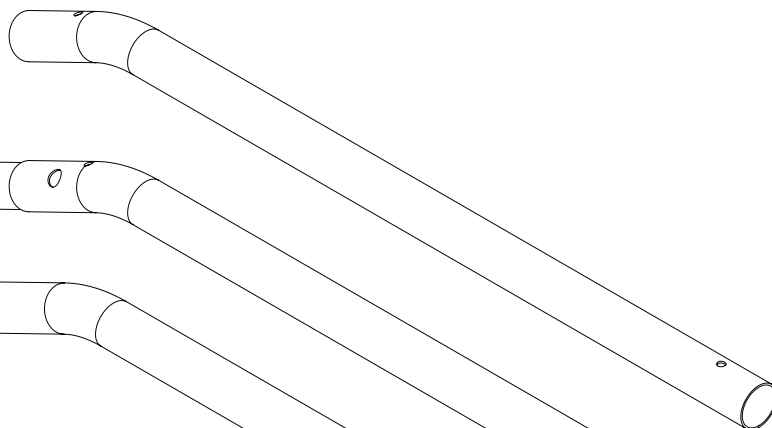

L2 x1

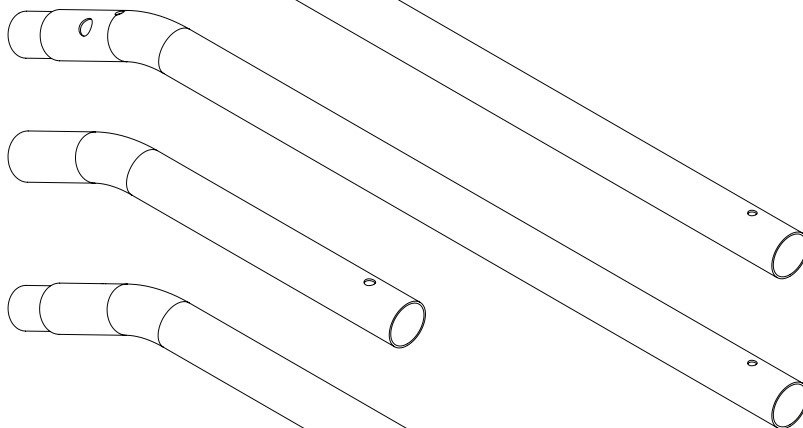

L3 x1

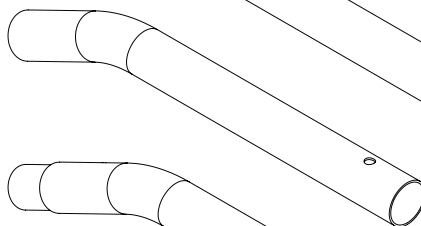

L4 x1

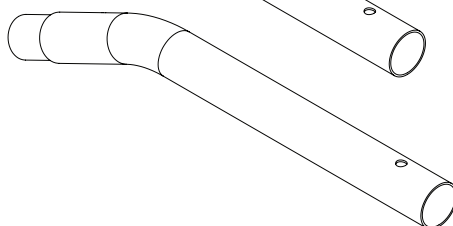

x40
L5

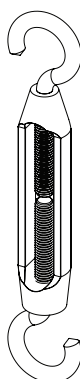

x5
L6

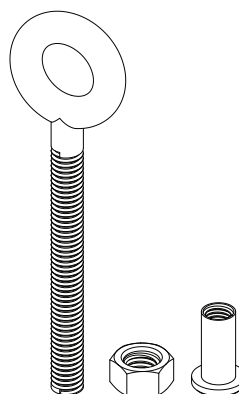

x5
L7

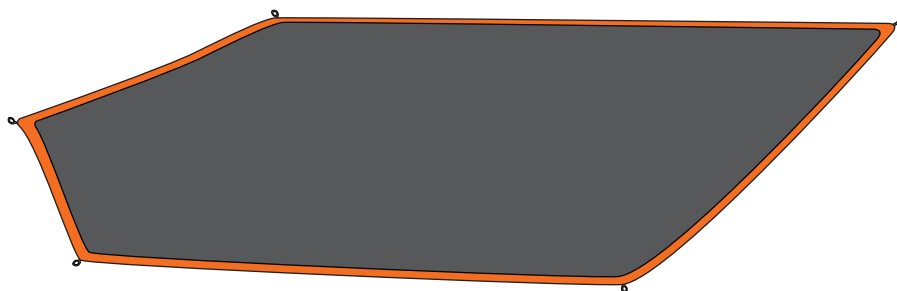

x1
SHADE COVER



BOX I

12 x2

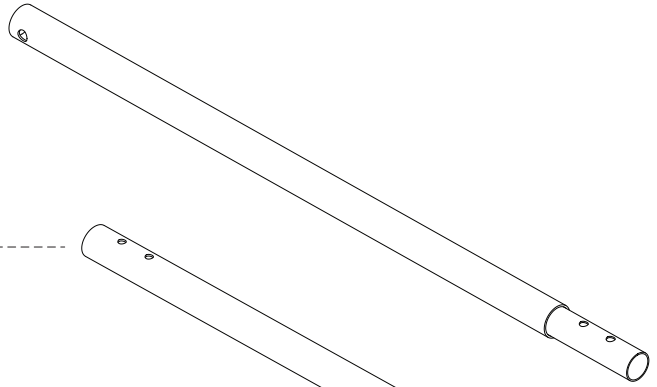

13 x1

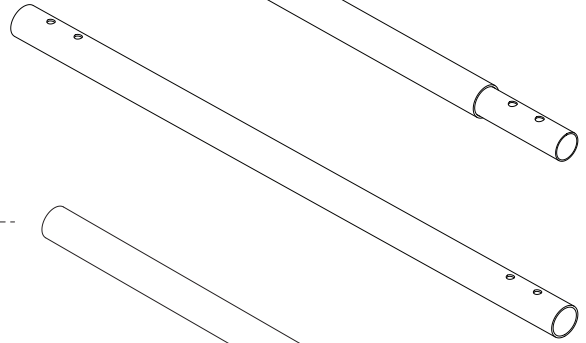

14 x1

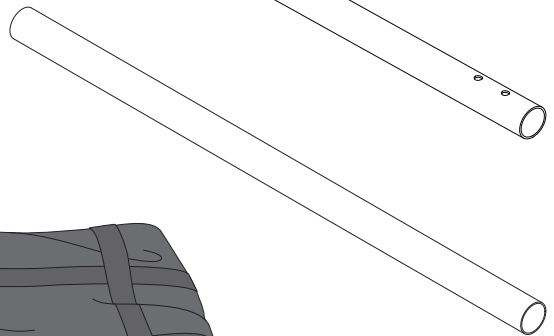

x2
15



x2
16



x2
17

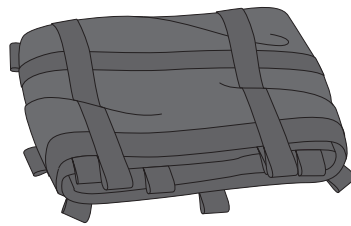

x1
19



x2
110



x2
111

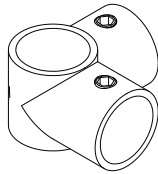

x2
18



x8
112

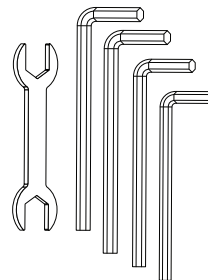

x1
113



BOX J

J1 x2

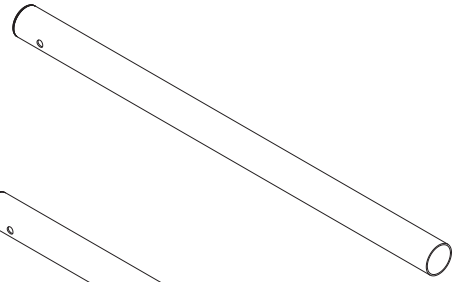

J2 x2

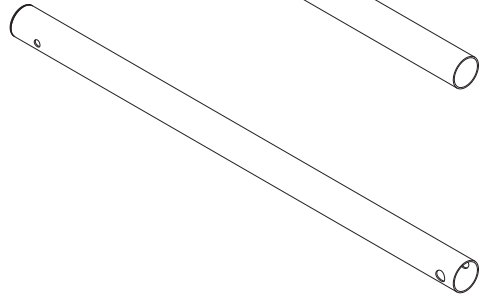

J3 x1

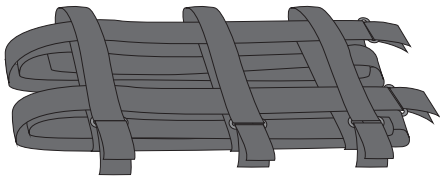
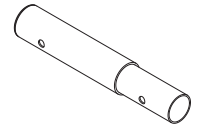

x1
J4

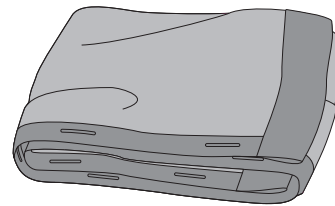

x1
J5

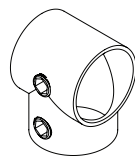

x2
J6



x1
J7



4.0. Assembly Instructions

4.1. Full Assembly Instructions

1

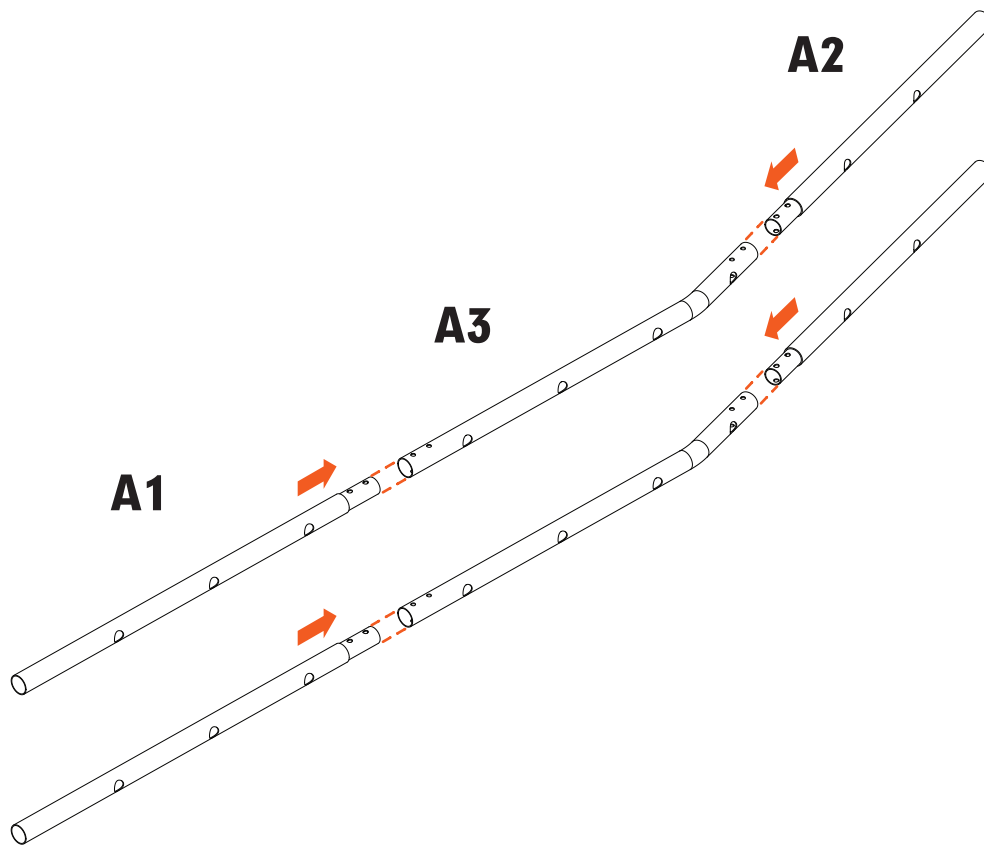

2

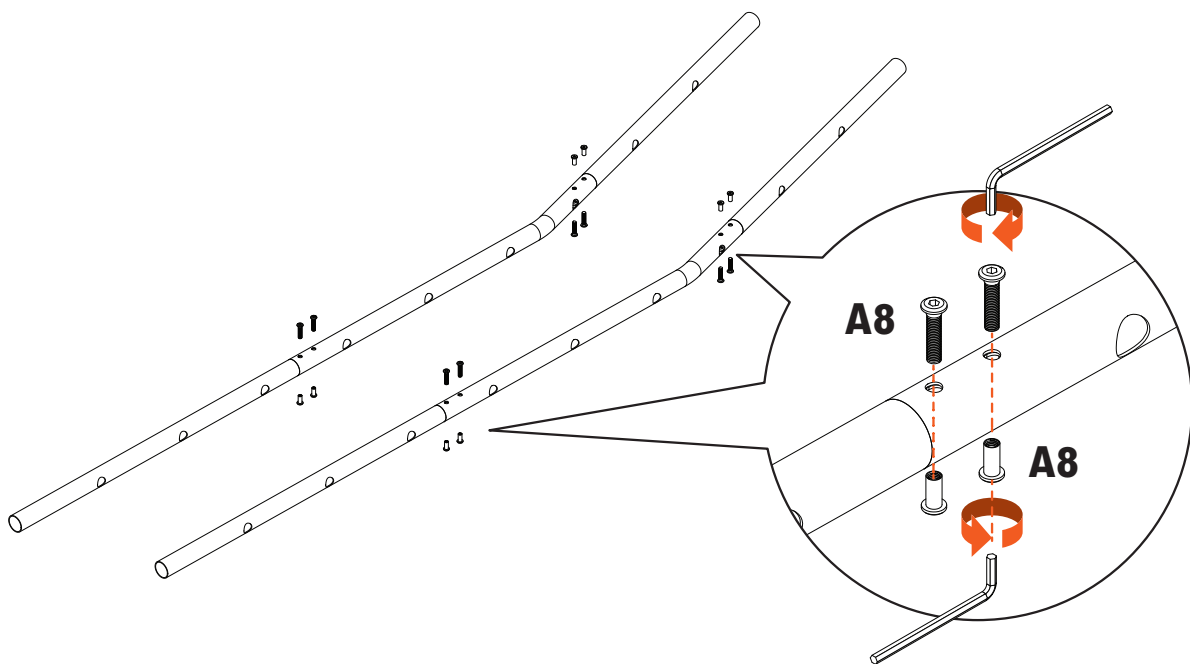

3

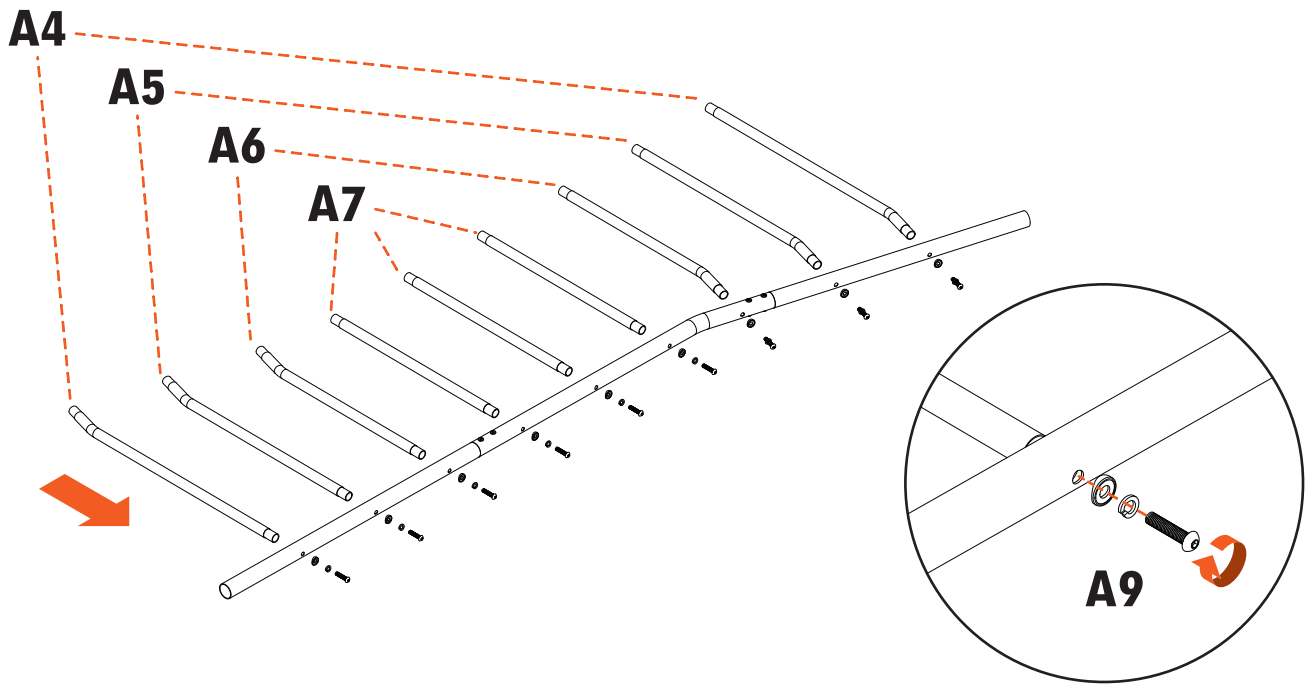

WARNING! ONLY HAND TIGHTEN BOLTS AND ENSURE THEY ARE VERY LOOSE! You may need to rotate some Monkey Bars to fit into the remaining Climbing Rail. **!**

4

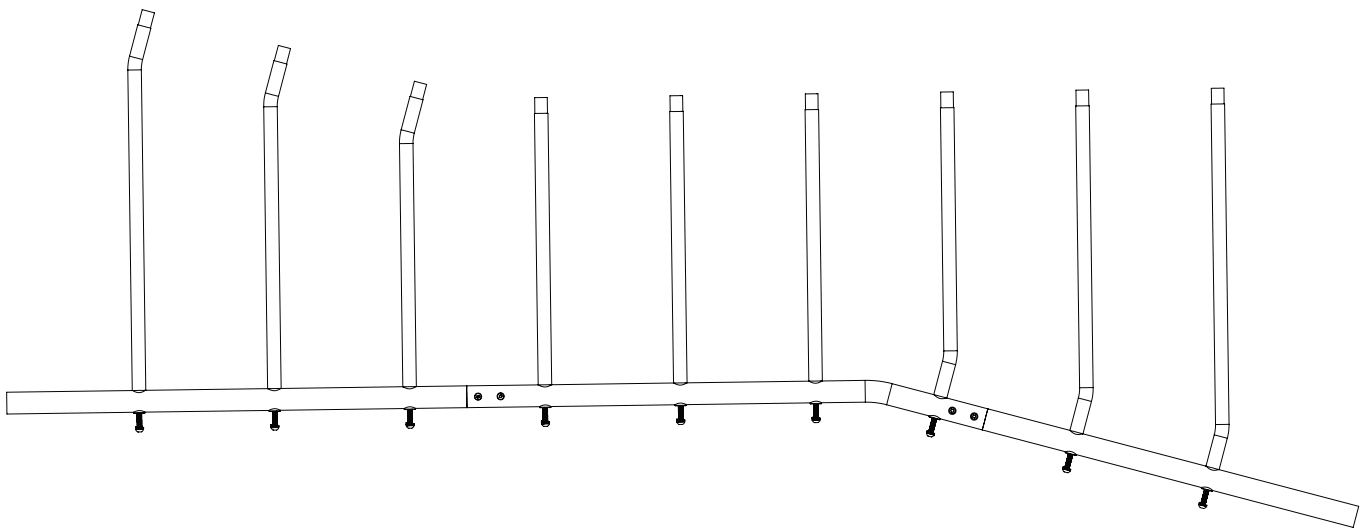

WARNING! Ensure Straight Climbing Bars A7 are in the middle; and Angle Climbing Bars A4, A5, A6 are on either ends of the Climbing Rails as indicated. **!**



5

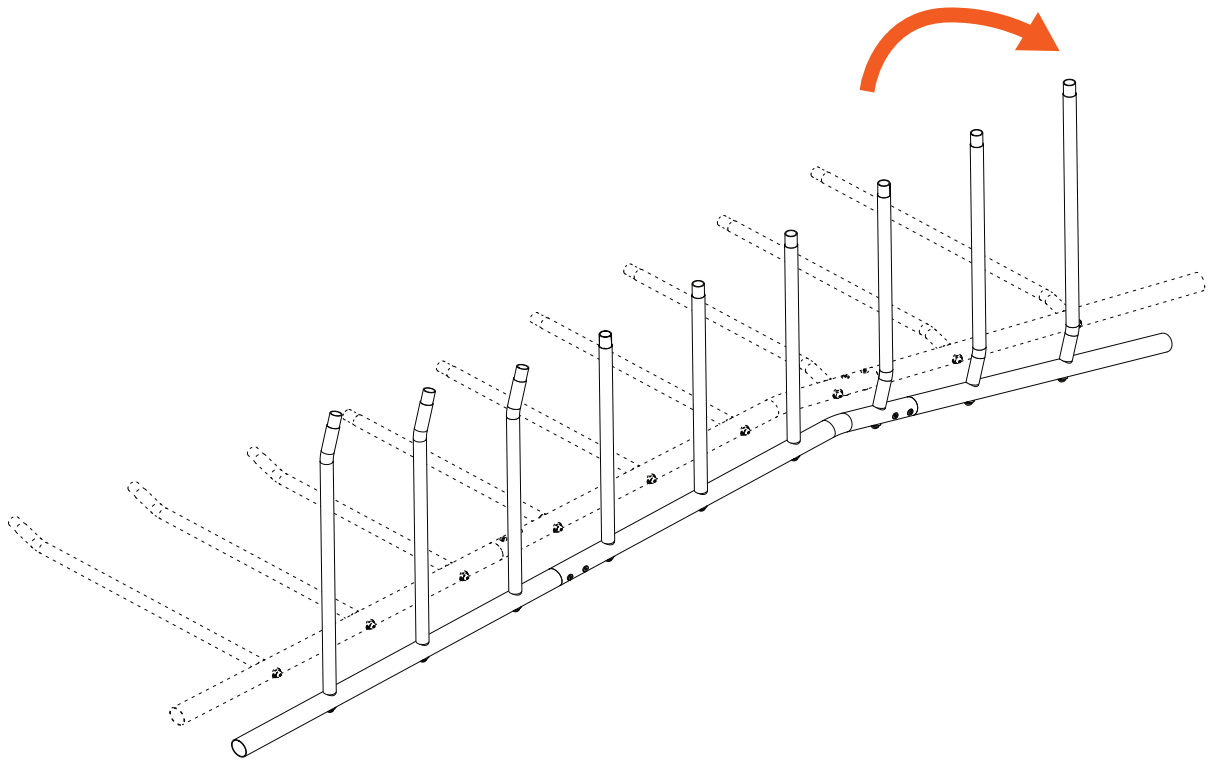

6

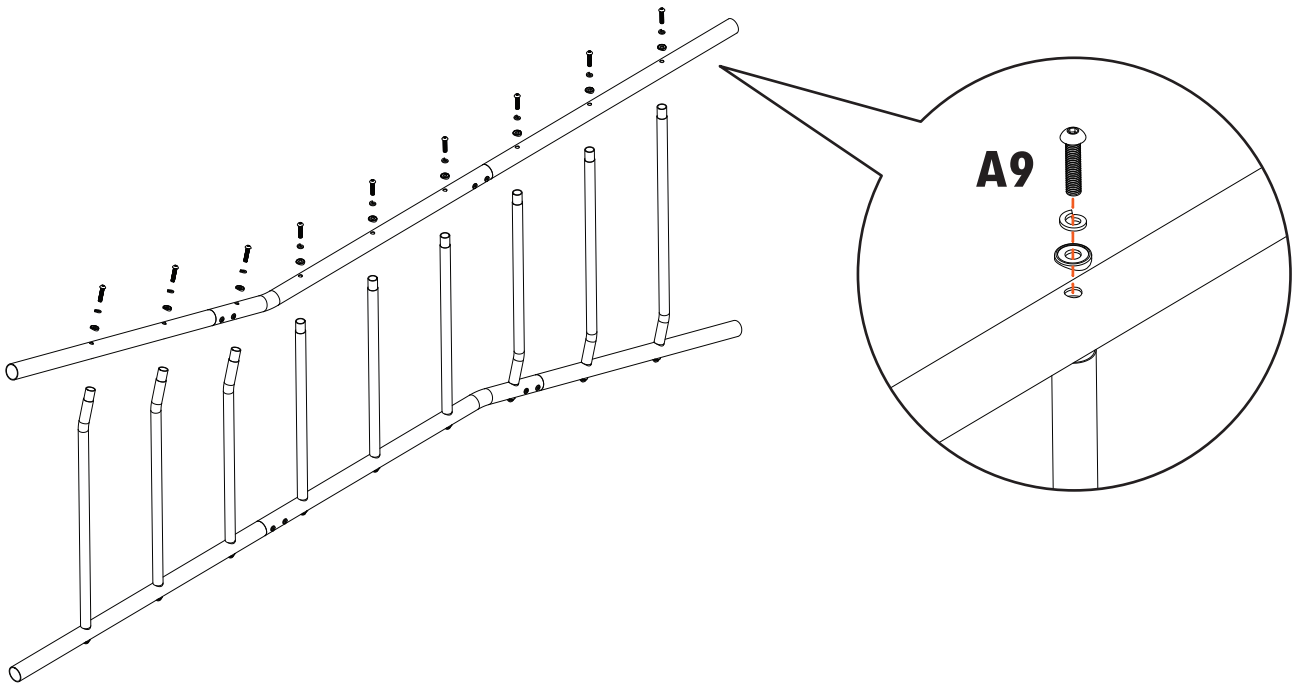

WARNING! ONLY HAND TIGHTEN BOLTS AND ENSURE THEY ARE VERY LOOSE! If having difficulties to get the Climbing Bars into the Climbing Rails, double check all bolts done in Step 3 are very loose.



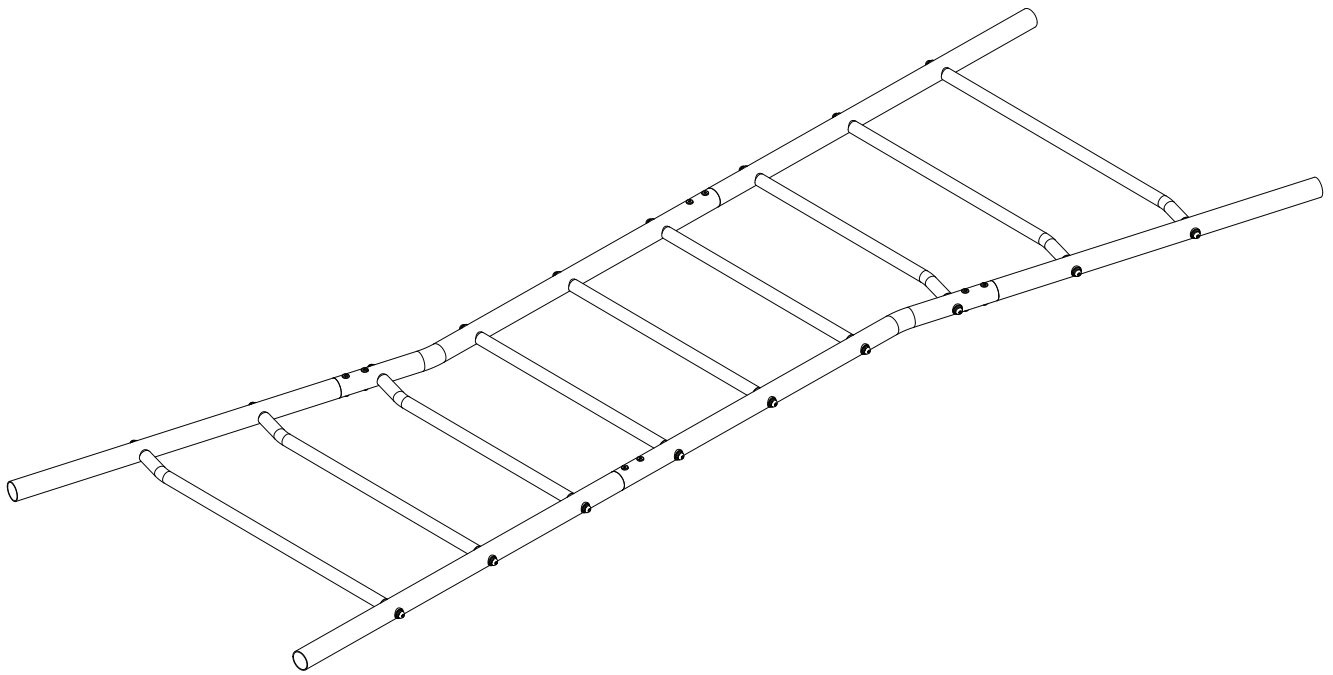

NOTE: Once all of the Climbing Bars are loosely threaded into the Climbing Rails, tighten all of the bolts to make sure the climbing section is secure.

7 x4

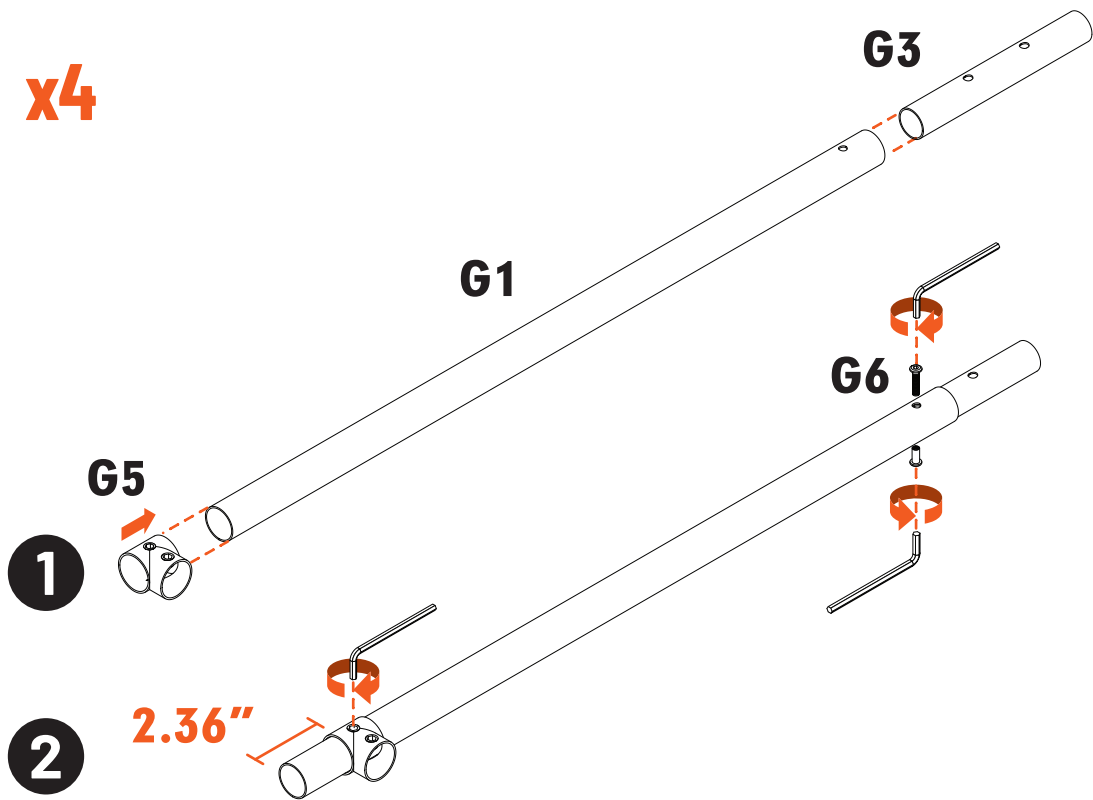

8

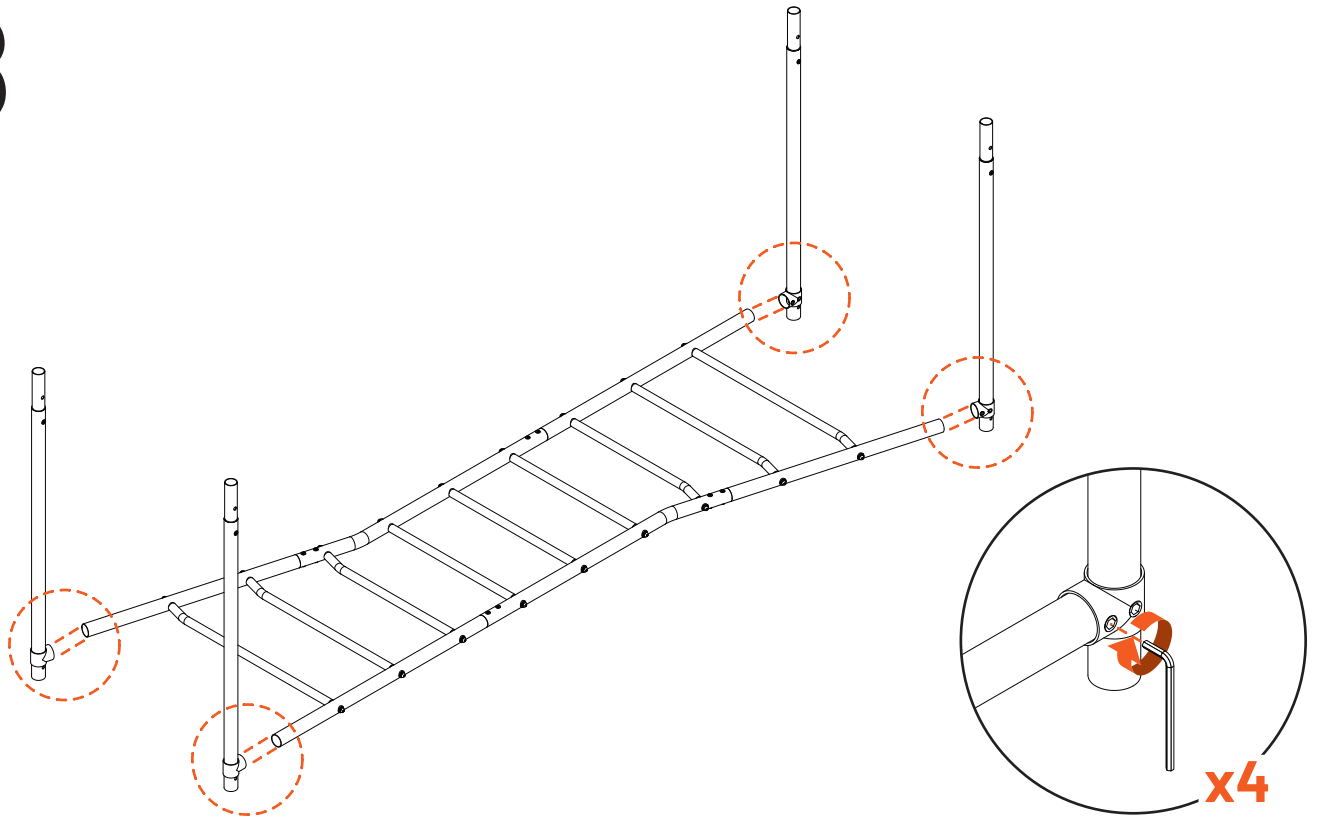

WARNING! Ensure all bolts are securely fastened before proceeding to the next step.

9

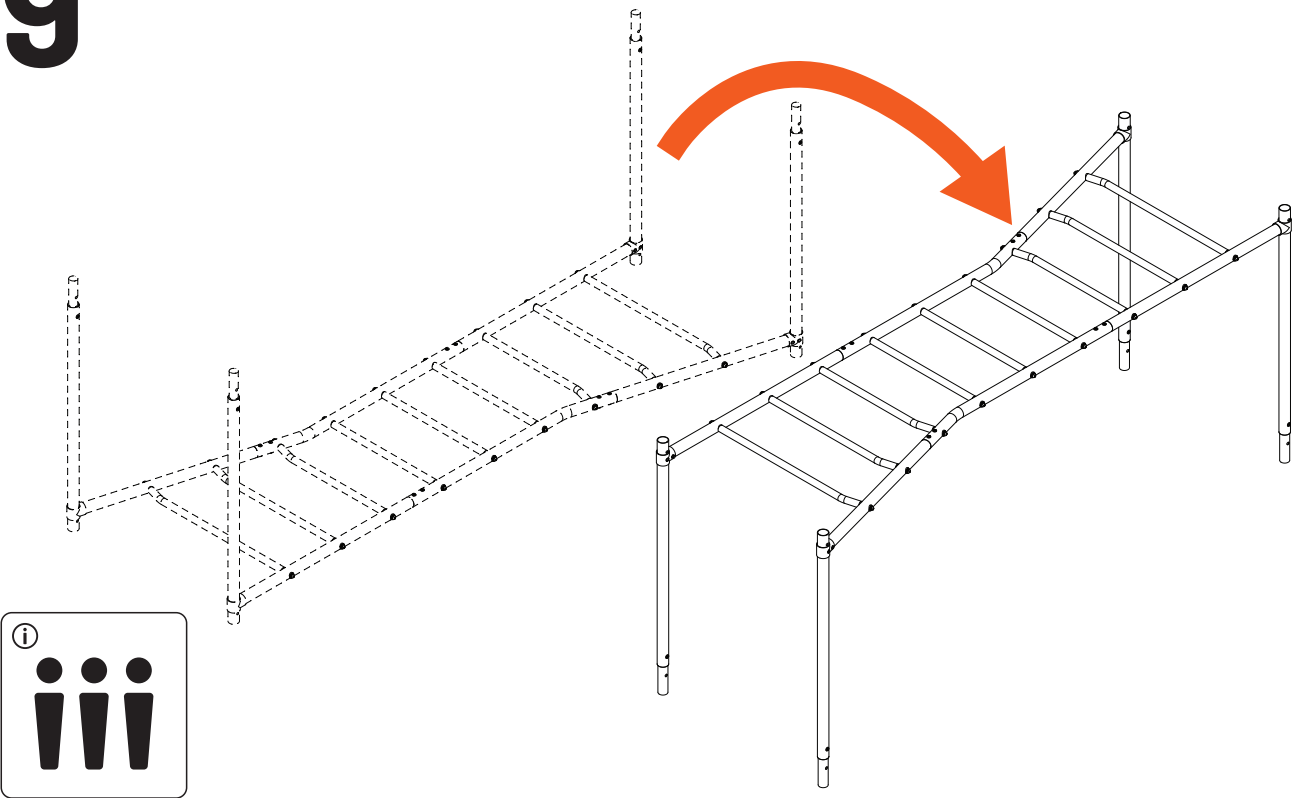

WARNING! Minimum of three people required for this step. Lift with straight back!



10

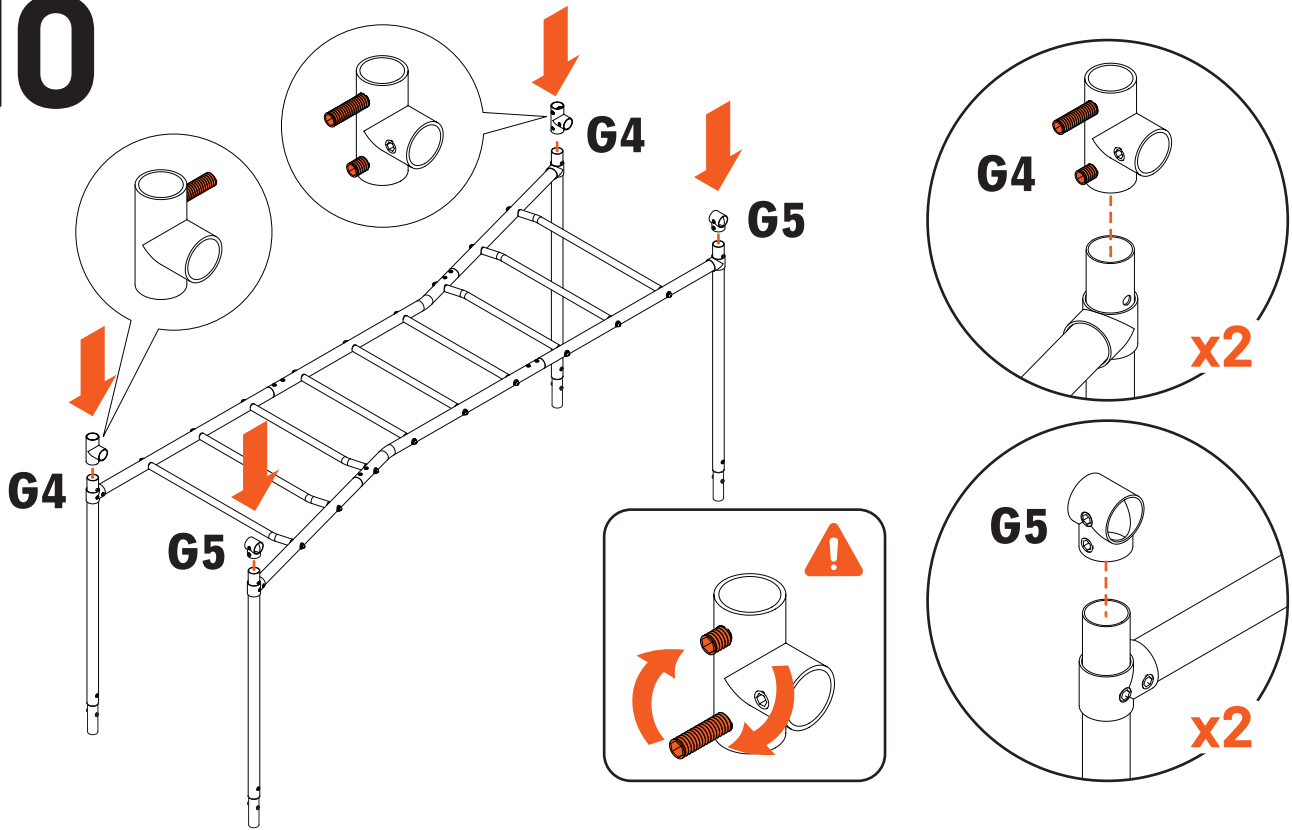

NOTE: Pay attention to orientation of G4 Joiners. Ensure **Long Grub Screws** are positioned as shown. If having difficulties, swap the position of the Grub Screws as indicated.



11

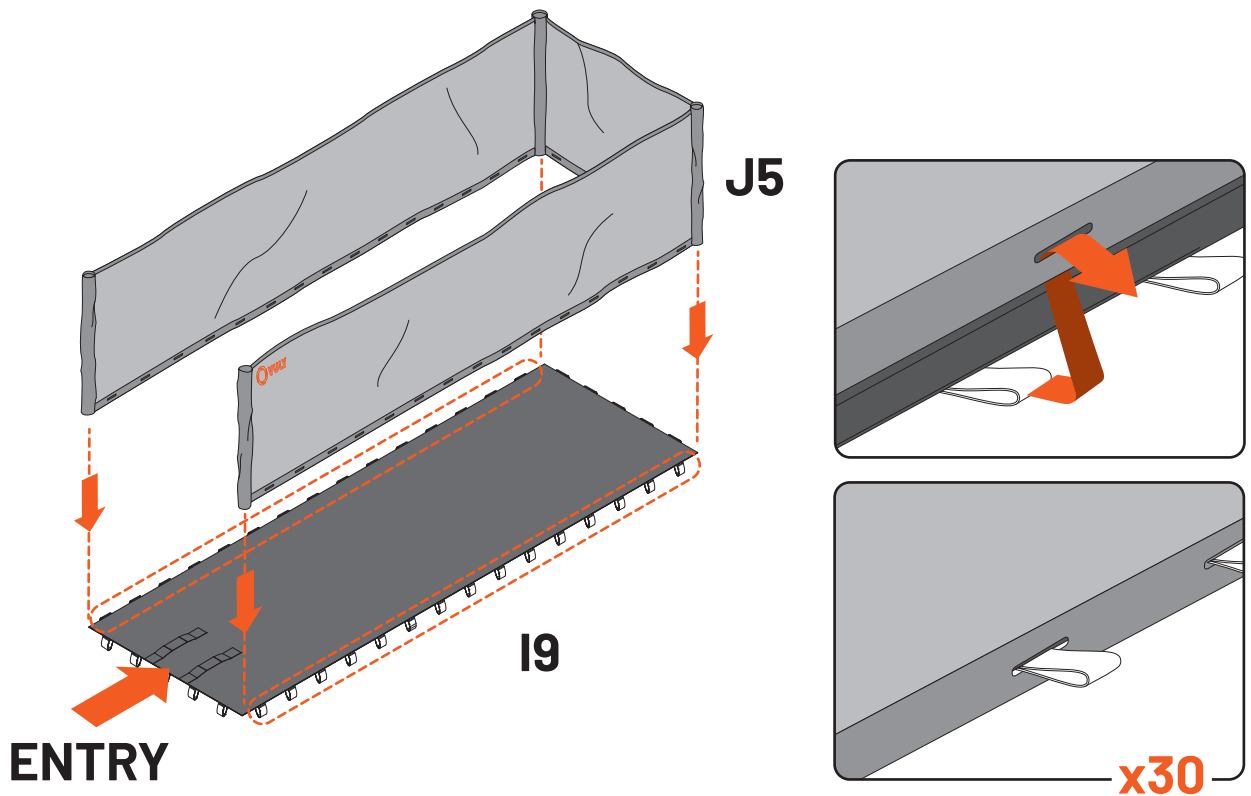

NOTE: Pay attention to Overpass Entry. Ensure Pull Handles on Overpass Platform faces up.



12

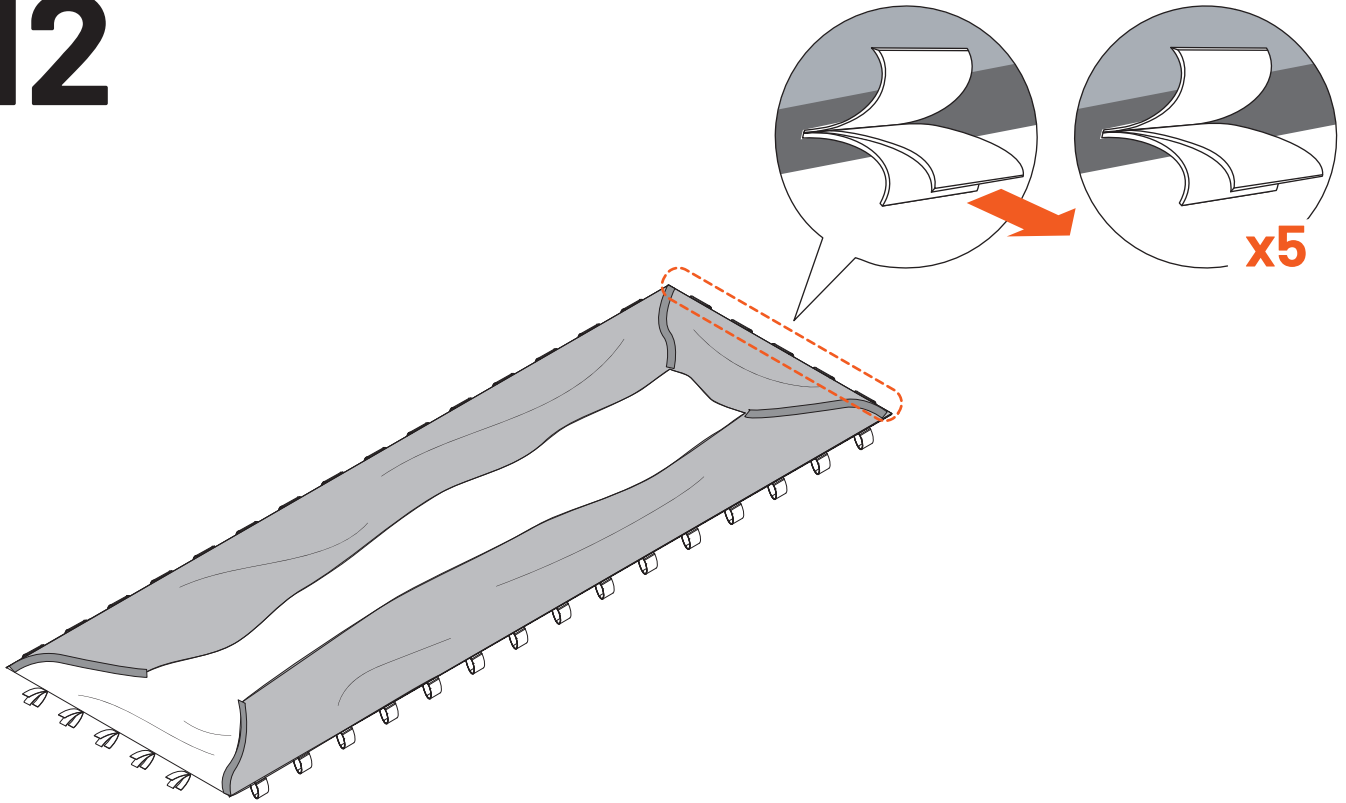

13

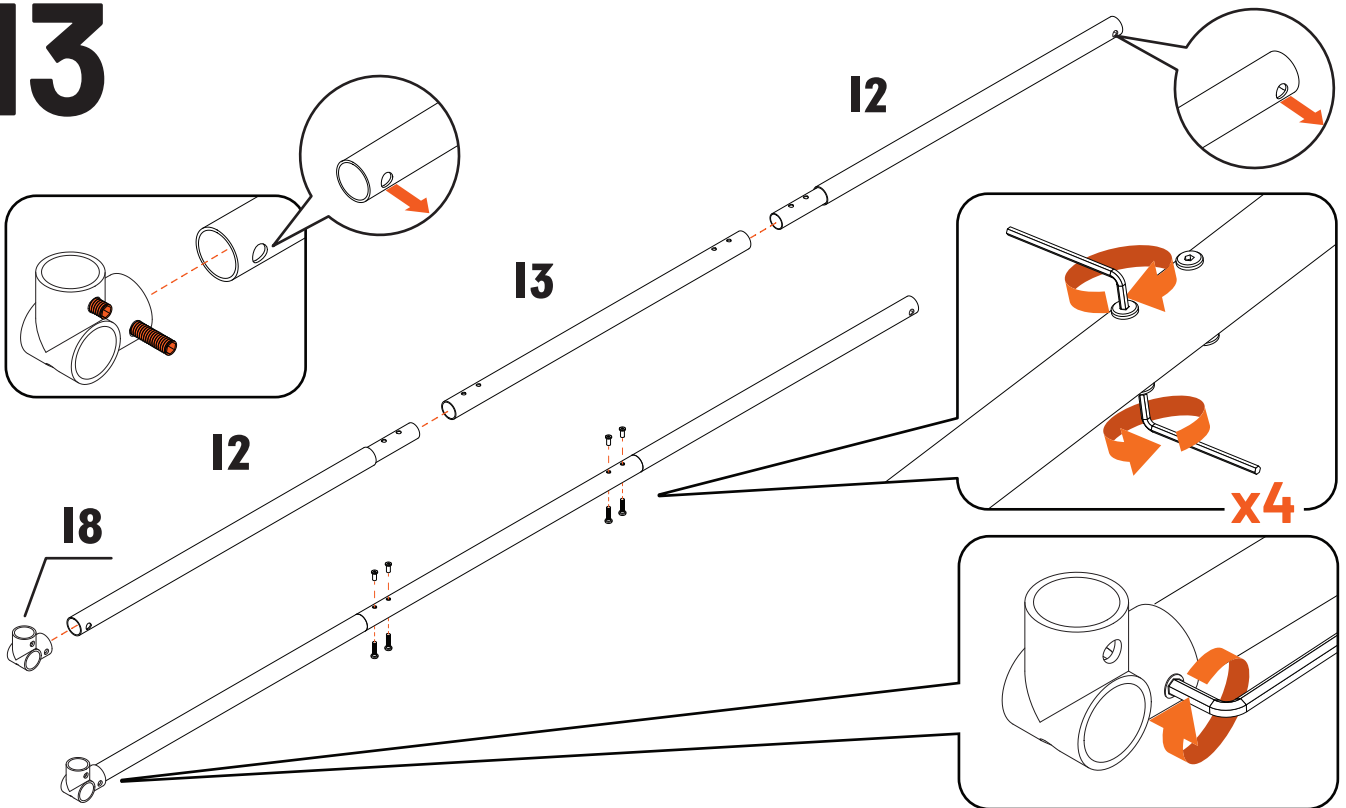



WARNING! Ensure holes on I2 Tubes are facing the same direction.
Ensure to connect Tube I2 with **Long Grub Screw** on Joiner I8. Pay attention to orientation of Joiner.



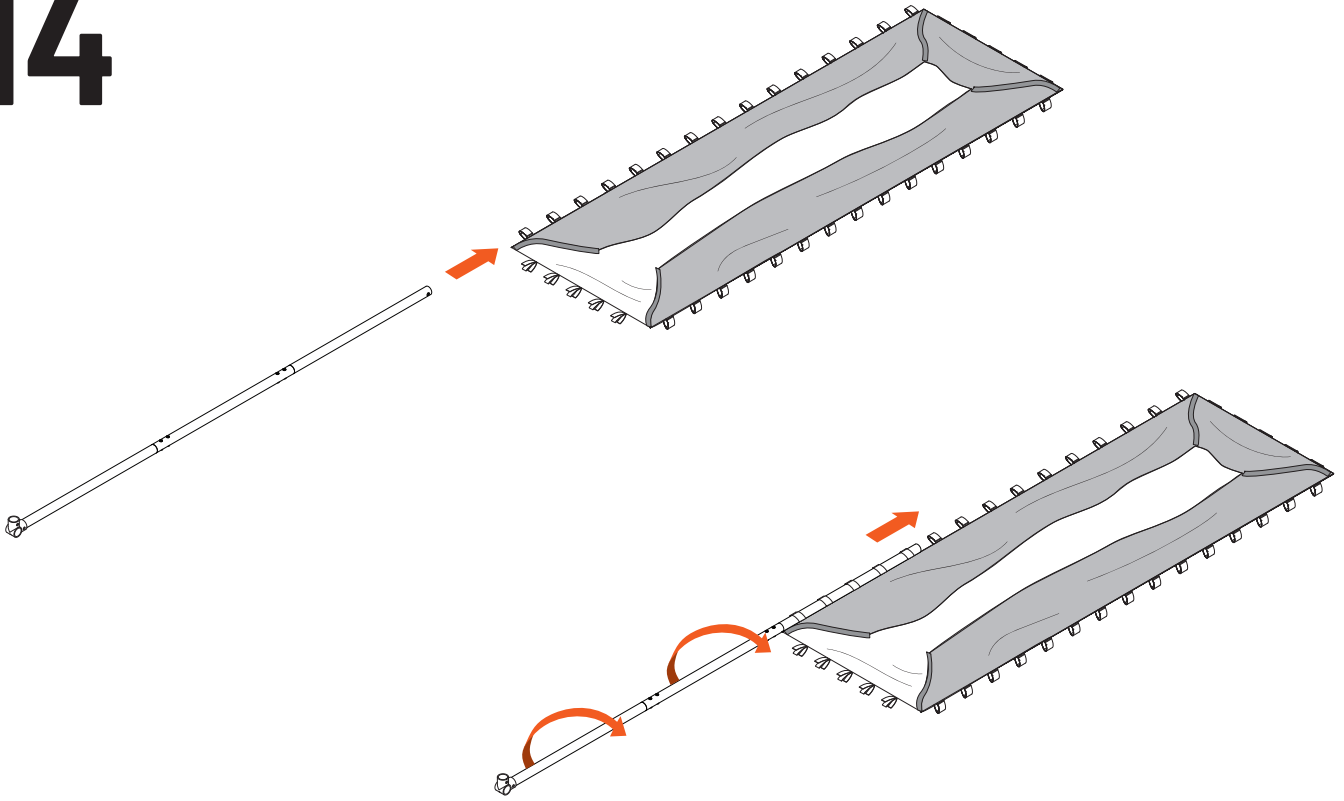

14

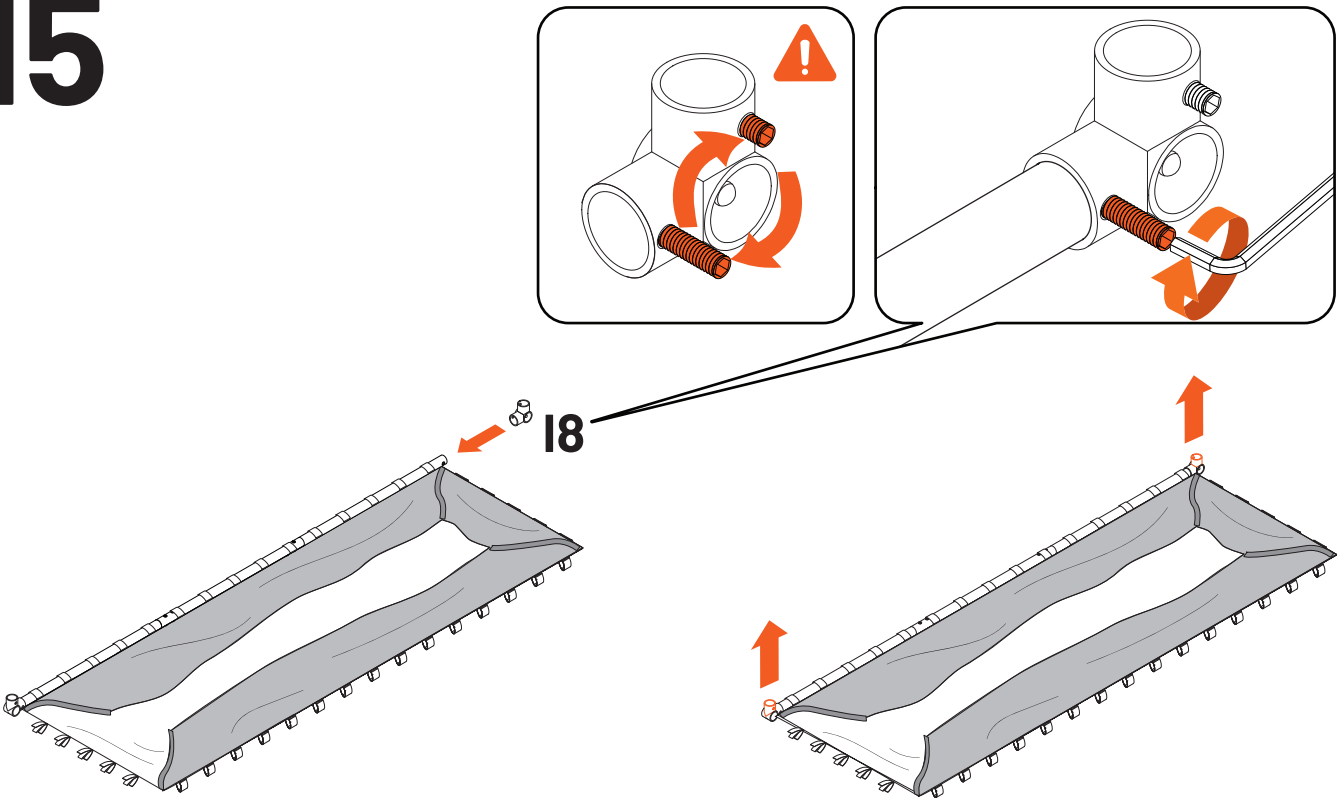

 **NOTE:** If having difficulties looping the tube through, try twisting it while feeding. 

15



 **WARNING!** Ensure to connect Tube I2 with **Long Grub Screw** on Joiner. Pay attention to orientation of Joiner. If having difficulties with joiner orientation, swap position of Grub Screws as shown. 



16

OPTIONAL

**CARGO NET
ACCESSORY**

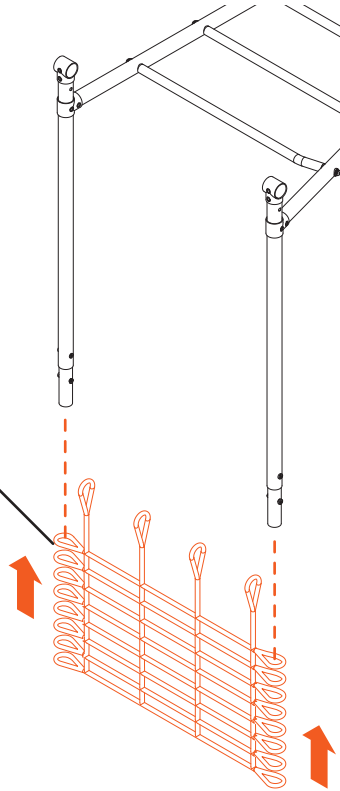

17

OPTIONAL

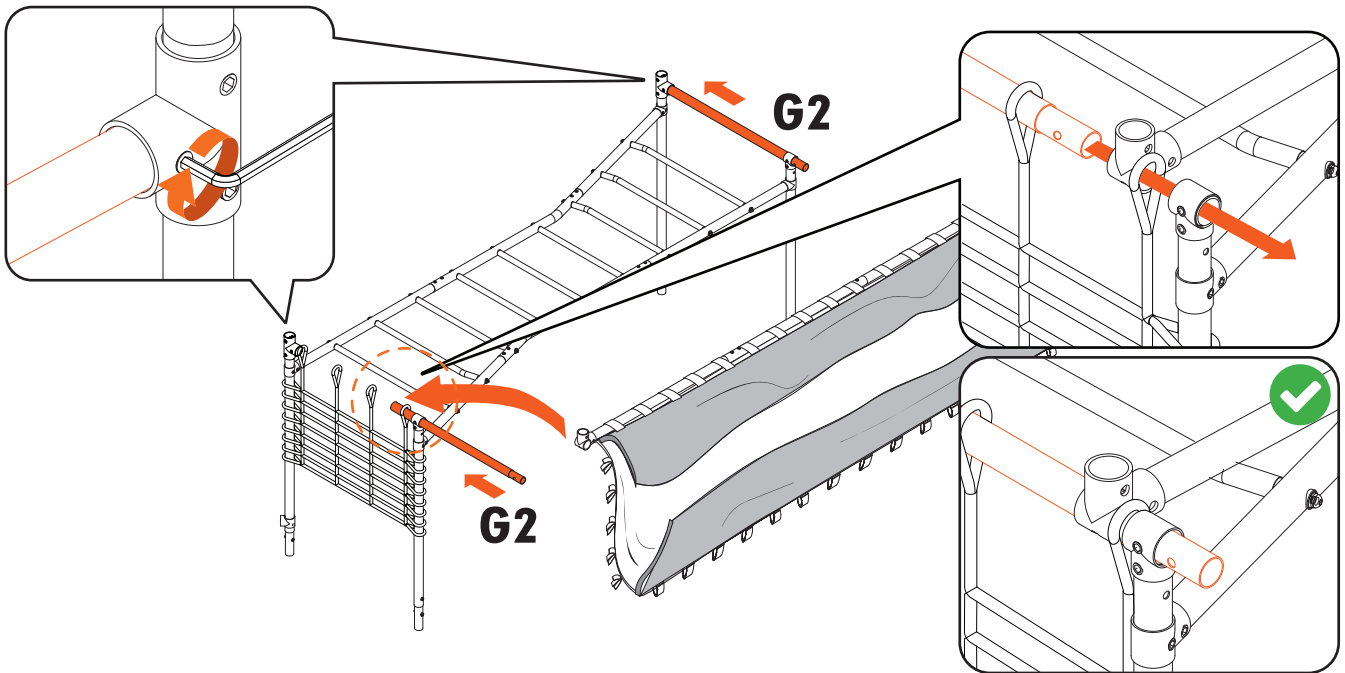

WARNING! Pay close attention to the Entry of Overpass. The Overpass can only be installed as shown in diagram, not the opposite. **!**



18

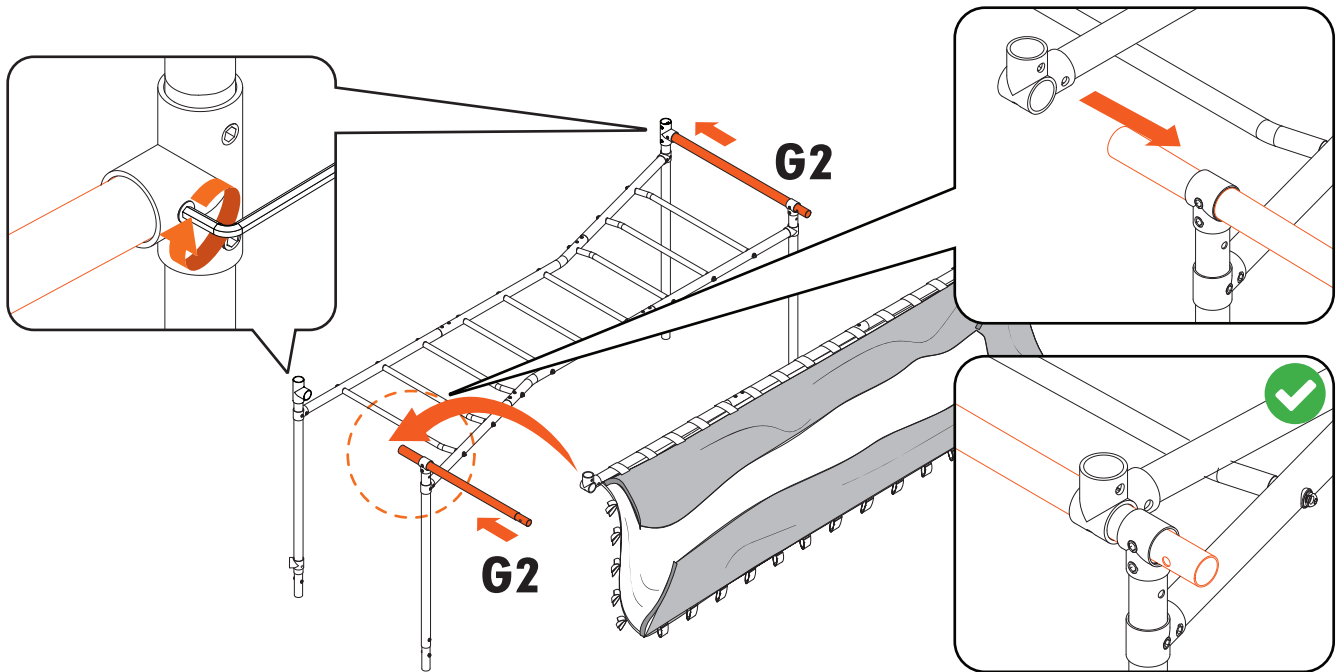

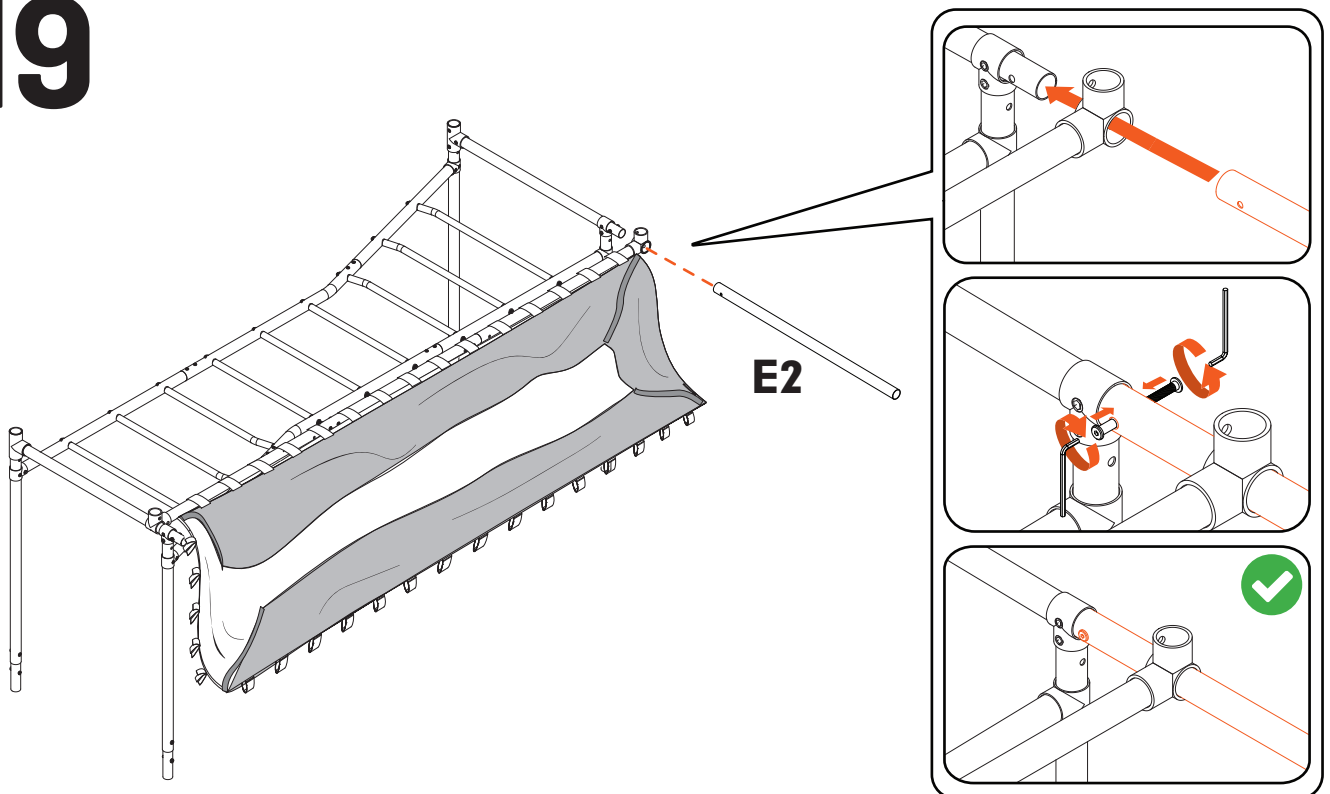

⚠ WARNING! Pay close attention to the Entry of Overpass. The Overpass can only be installed as shown in diagram, not the opposite. **⚠**

19

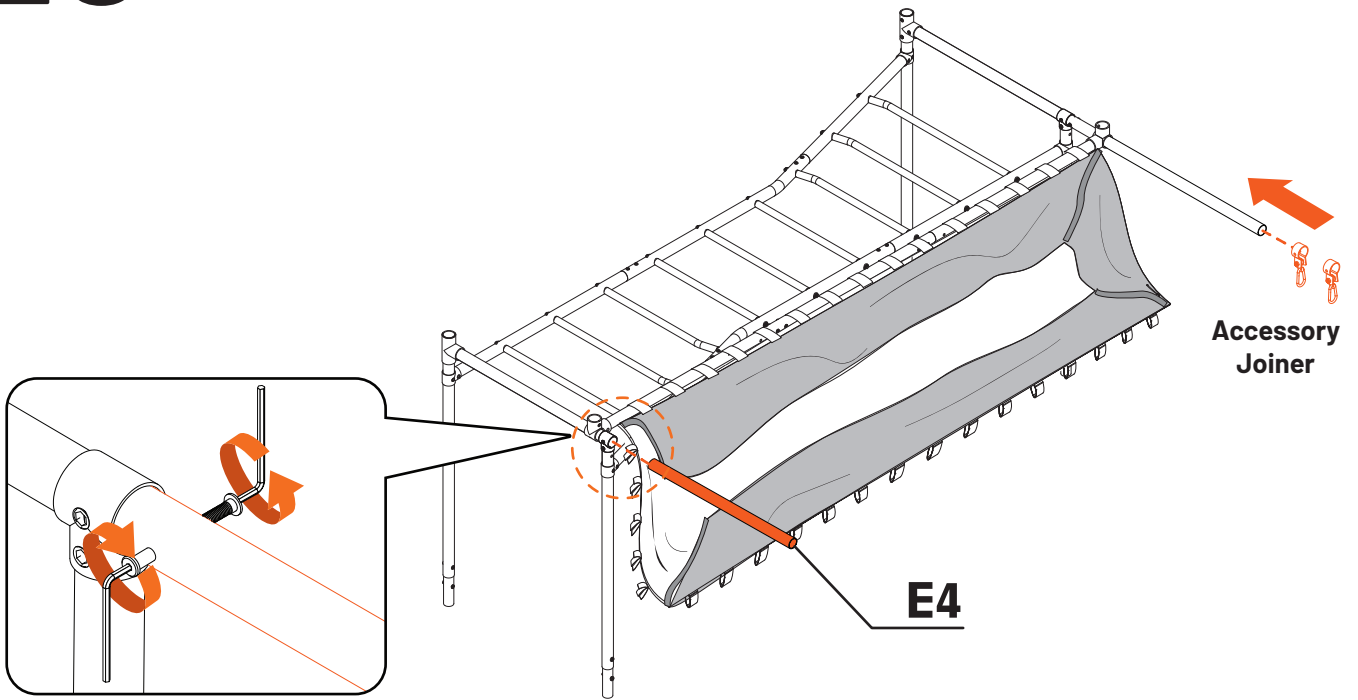

20



NOTE: Ensure Accessory Joiners are oriented to have bolt faces outside of the frame, and Nylon Nut faces inside of frame. 

21

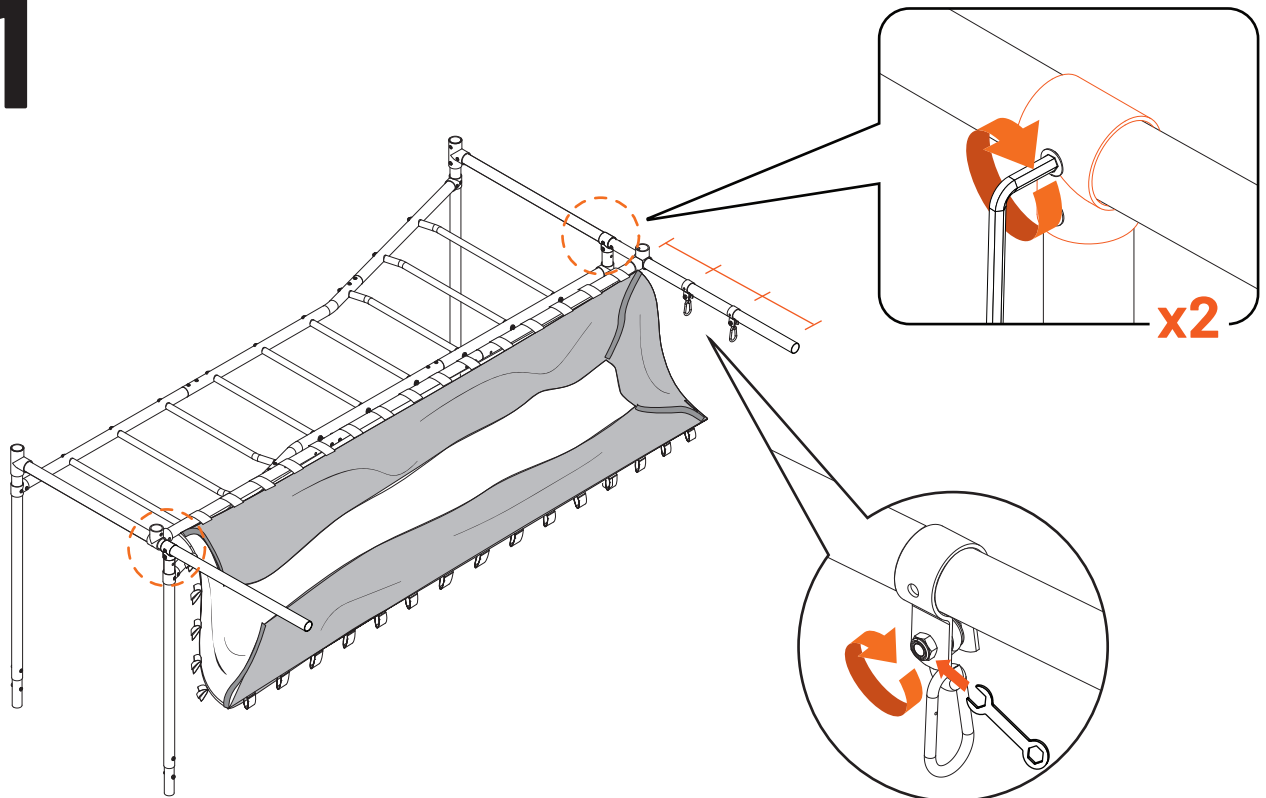

NOTE: Ensure Accessory Joiners are roughly equal distance apart before tightening. 



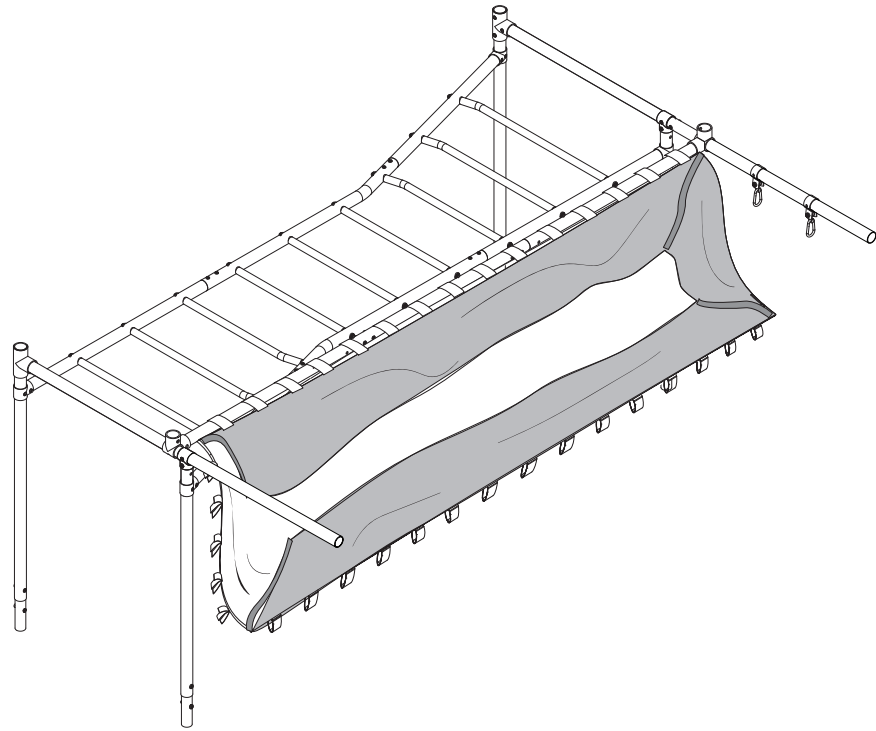

22

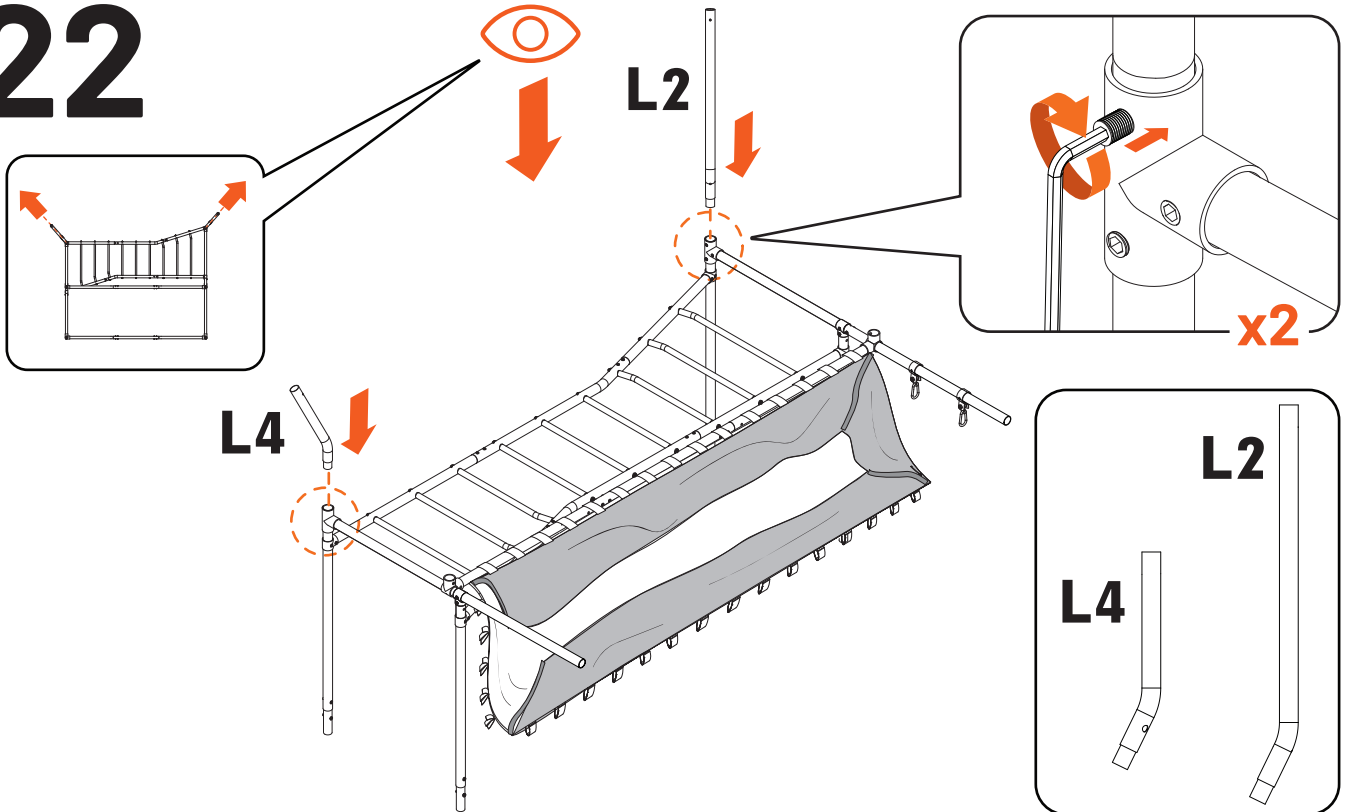

23 x2

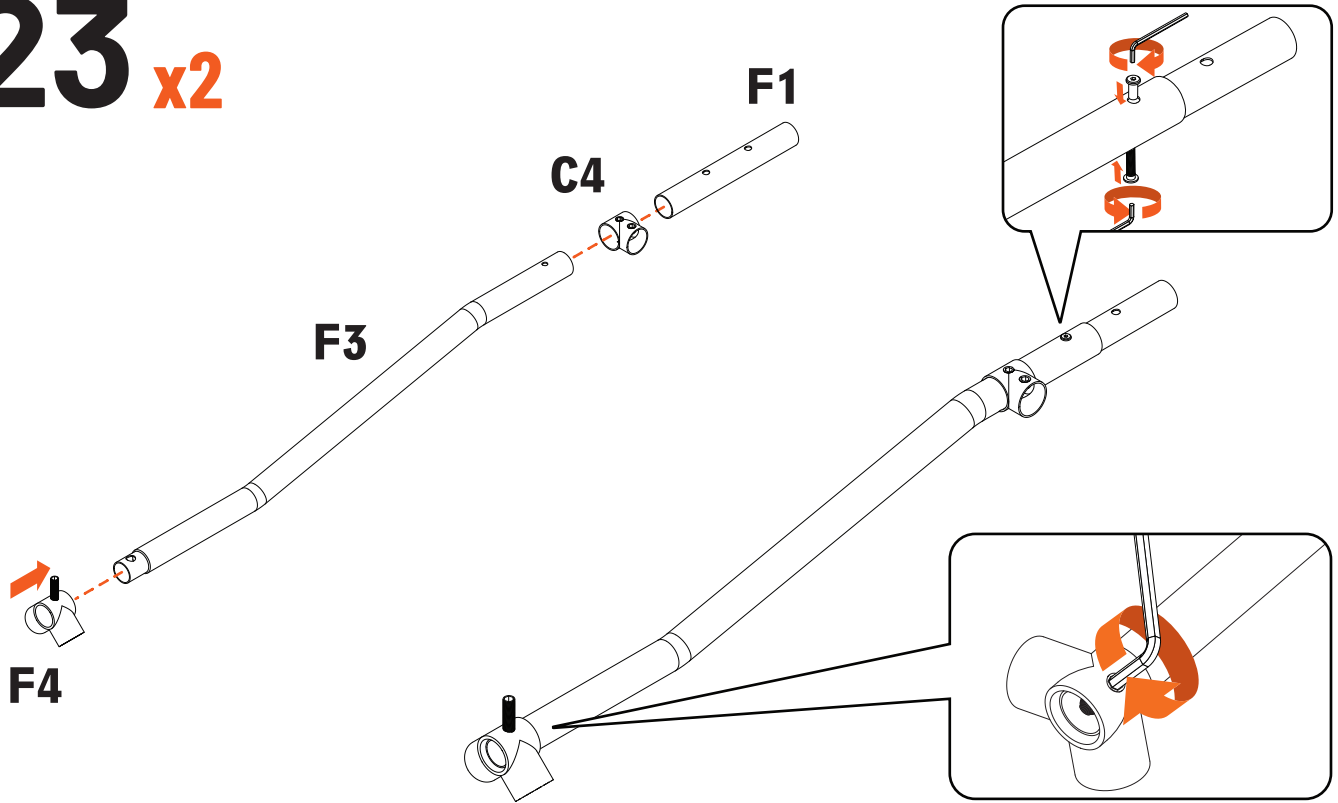

24

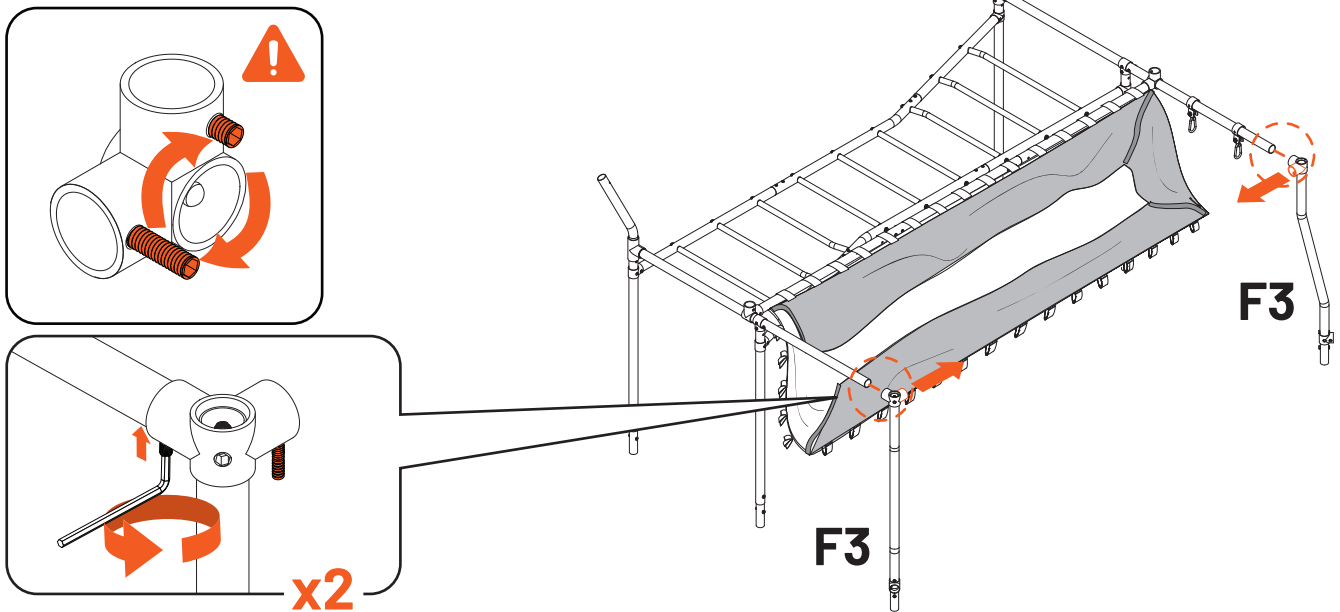

NOTE: Ensure Joiners are positioned as shown and only tighten short Grub Screws . If having difficulties, swap the Grub Screws as shown.



25

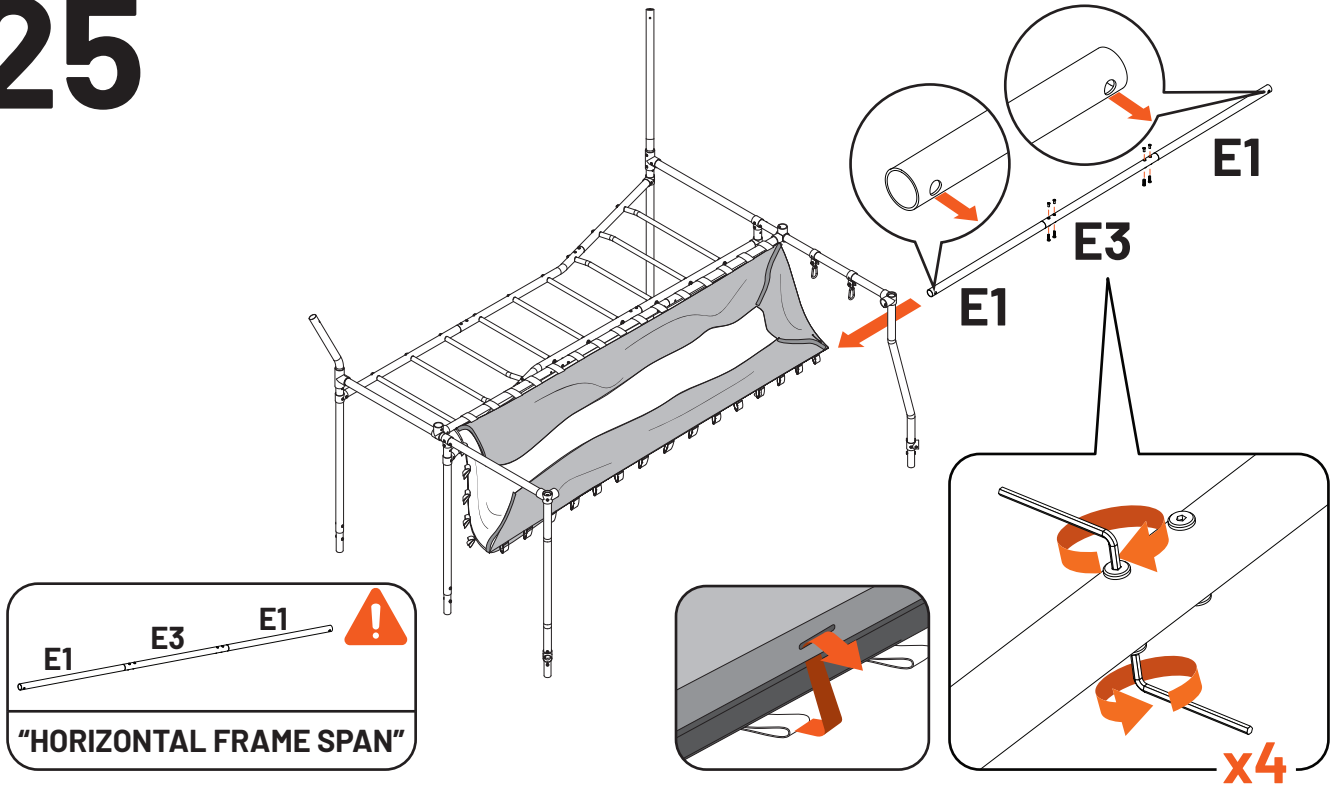

NOTE: Holes on E1 Tubes faces the same direction. Ensure Overpass Loops are secured through Safety Net Button Holes before looping Horizontal Frame Span through. **!**

26

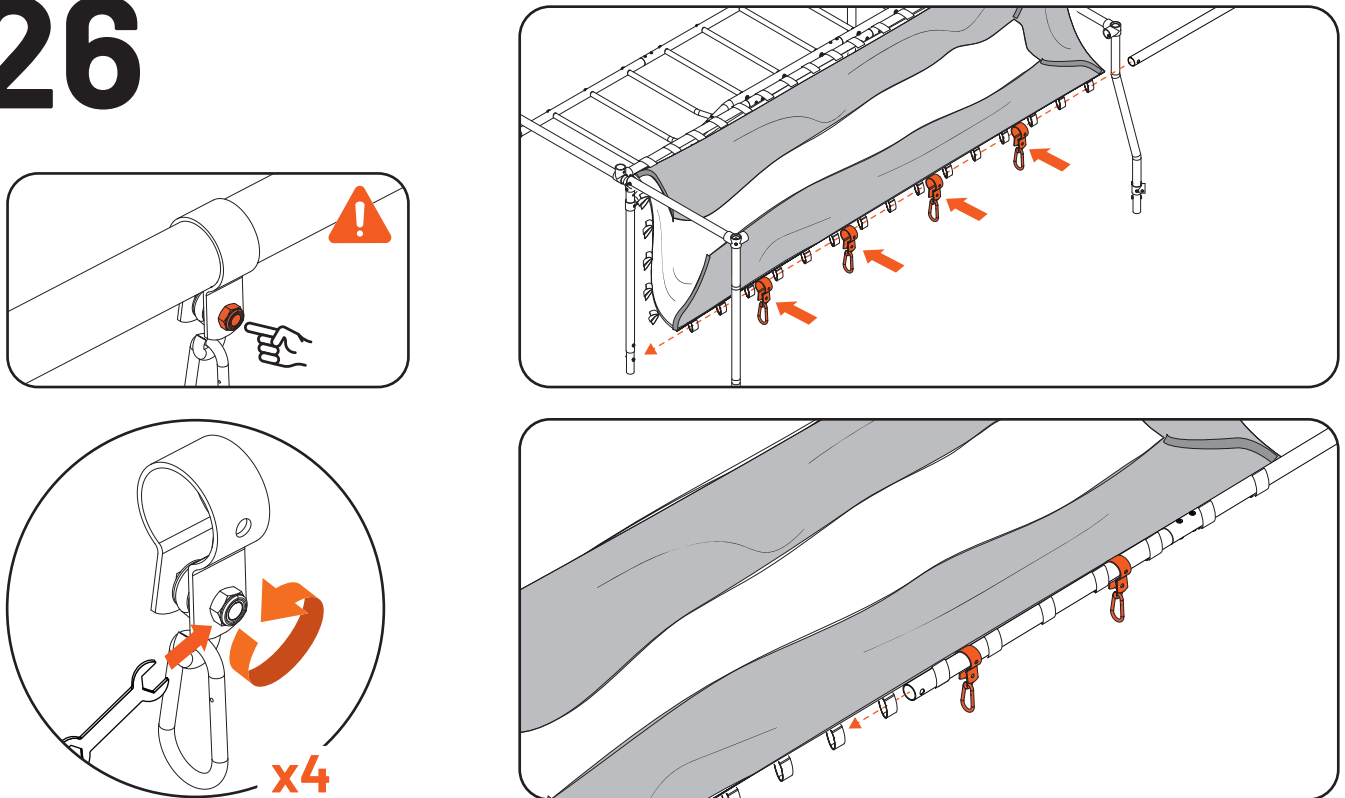

NOTE: Ensure Nylon Nut on Accessory Joiners are oriented outside of the frame. **!**



27

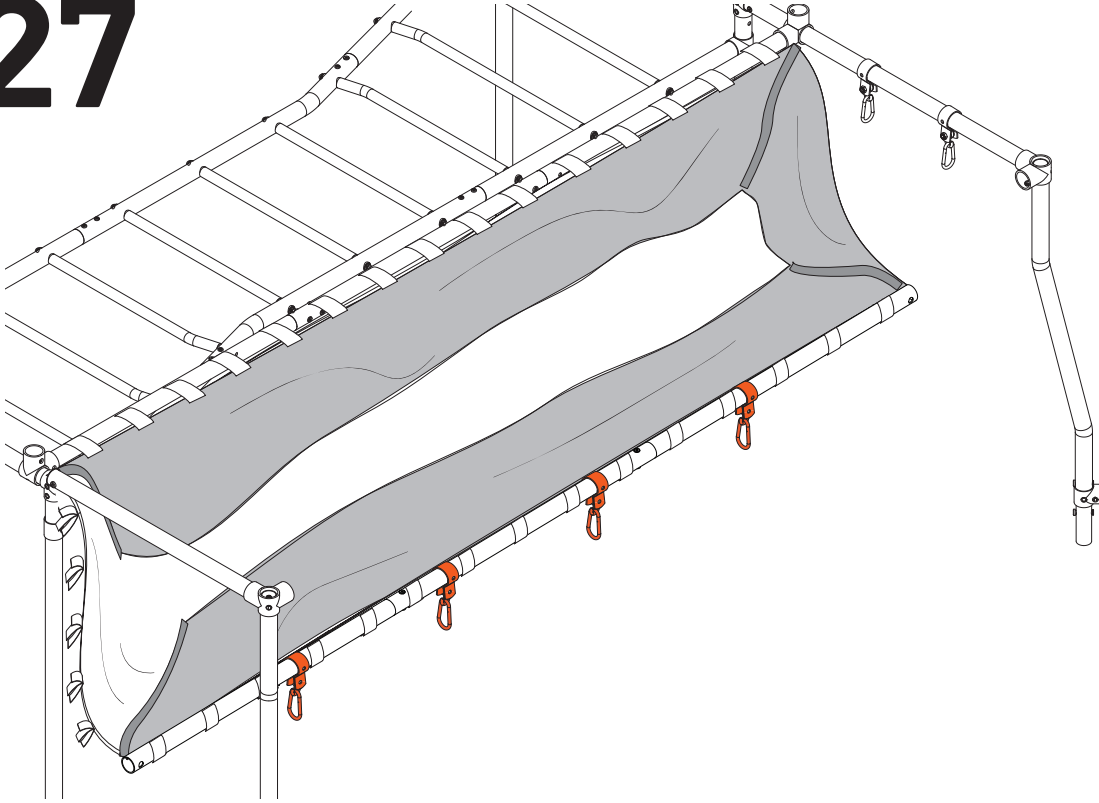

 **NOTE:** Only finger tighten the Accessory Joiners at this step. 

28

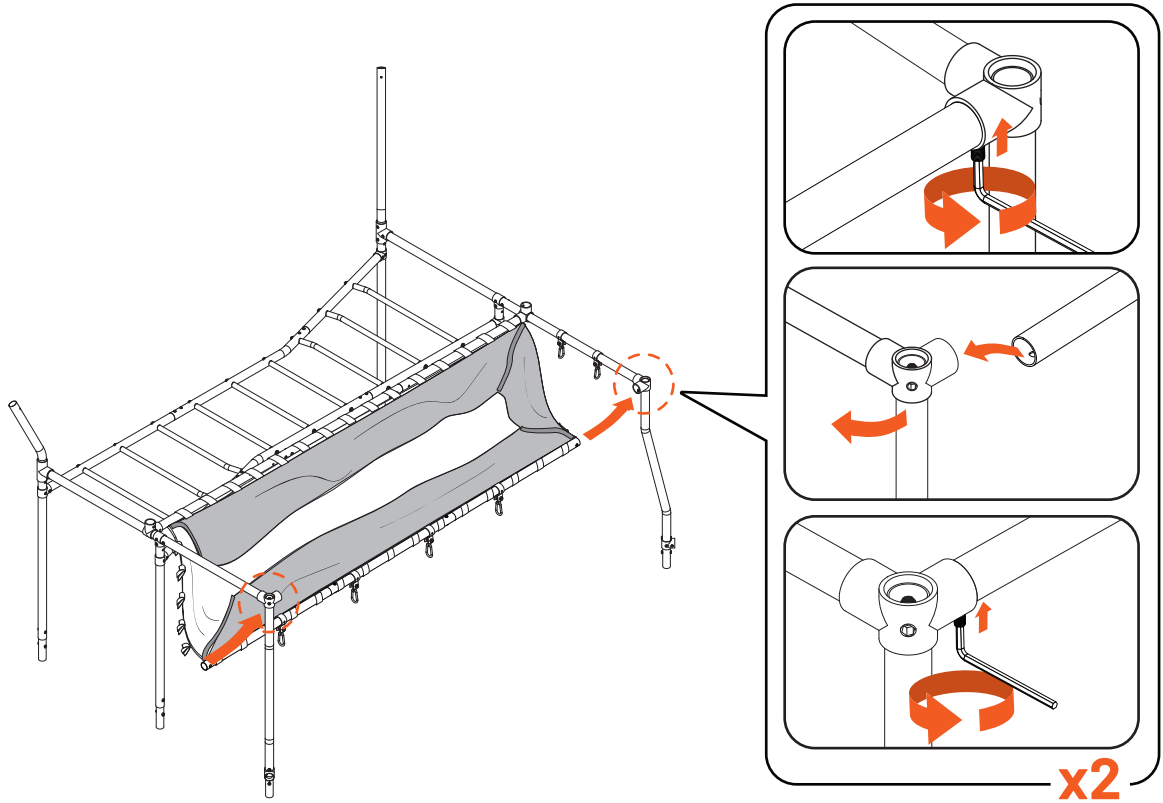

 **NOTE:** Ensure holes on Horizontal Frame Spanalign with hole on Joiners to receive Long Grub Screws. 



29

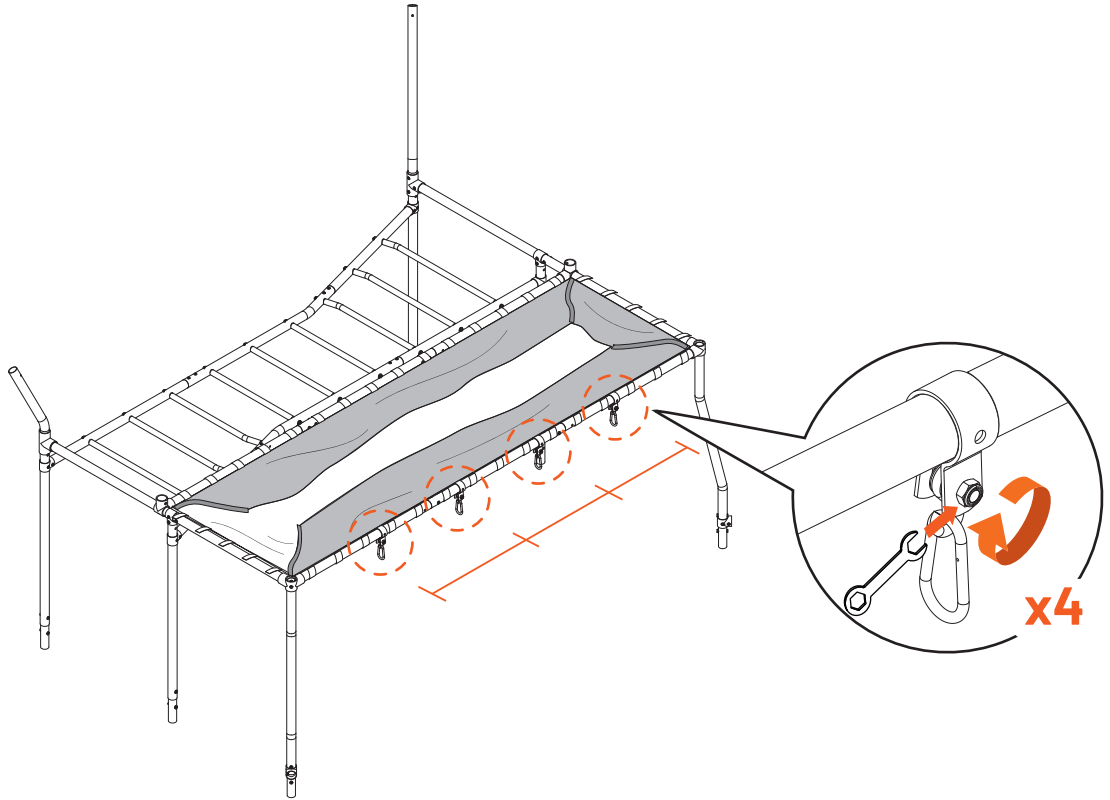

NOTE: Ensure Accessory Joiners are roughly equal distance apart before tightening.



30

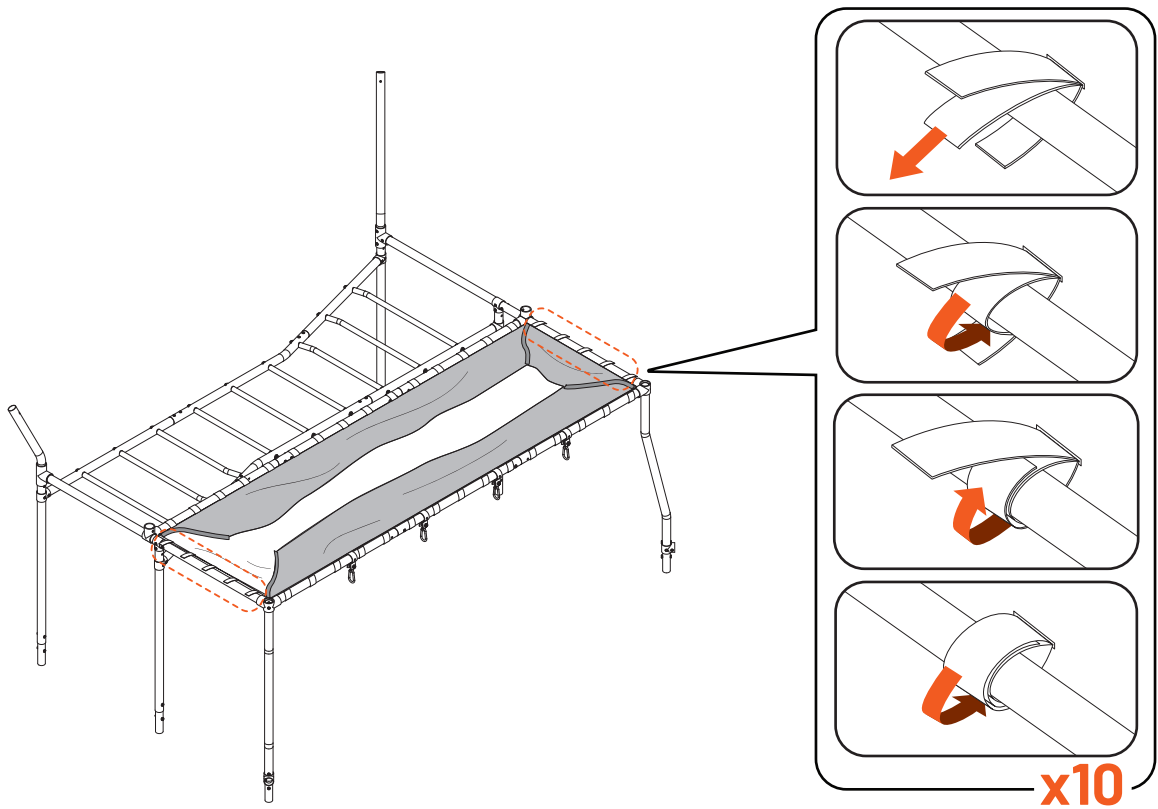

31

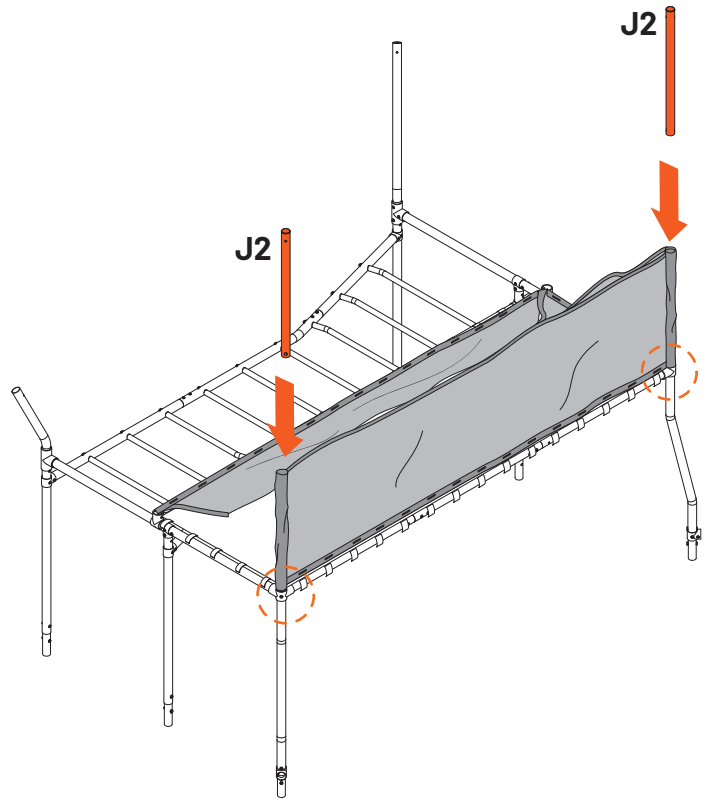
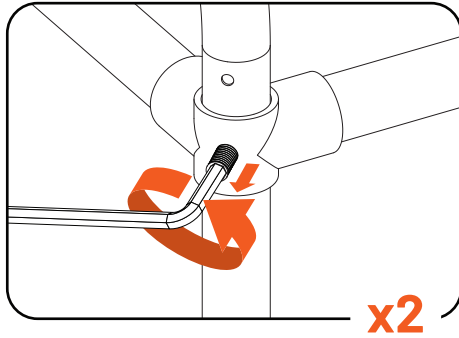
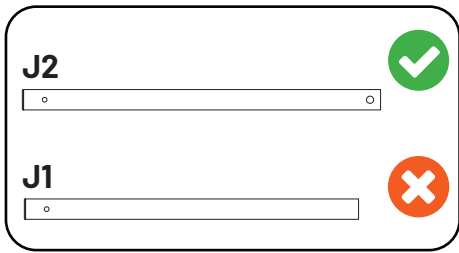

NOTE: Only undo grub screw enough to insert tube J2.

32

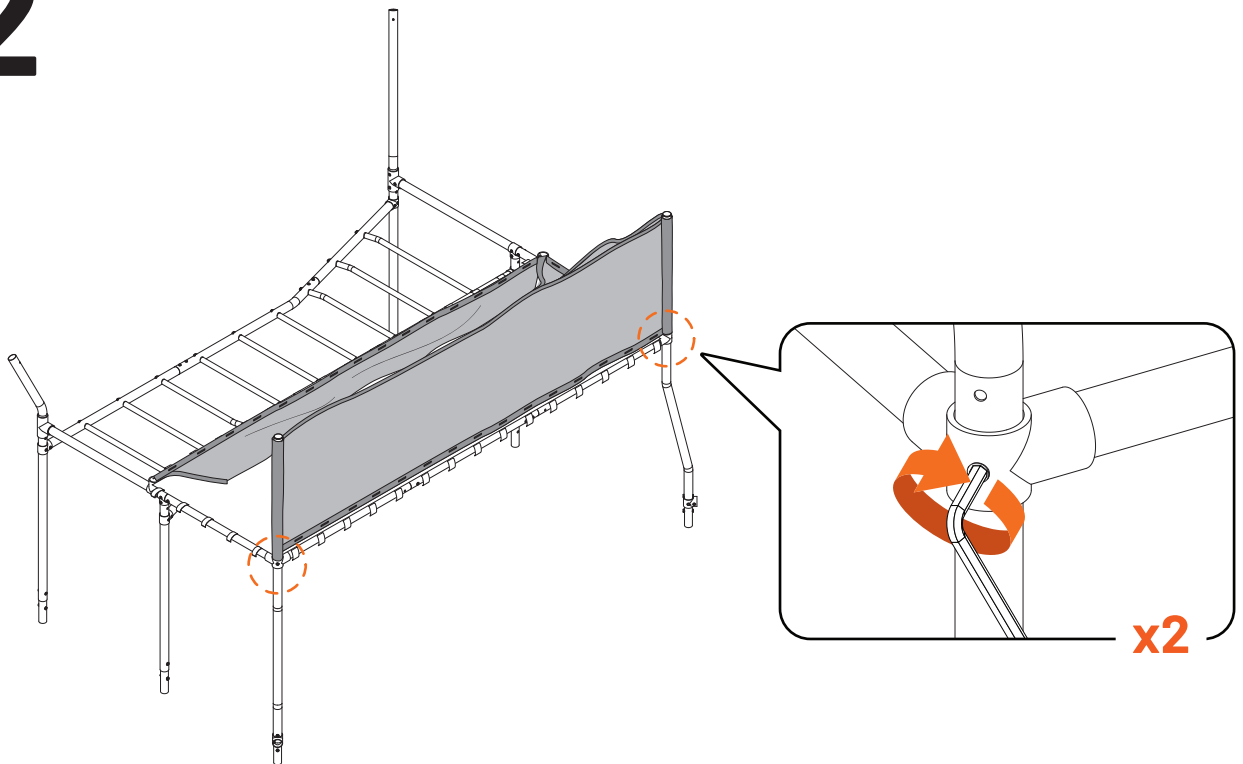

33

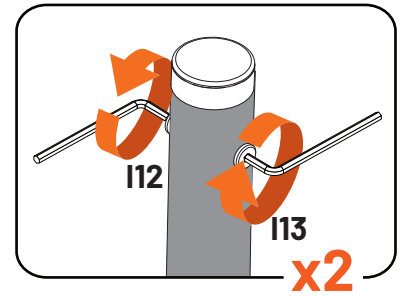
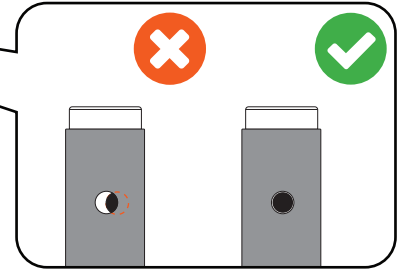
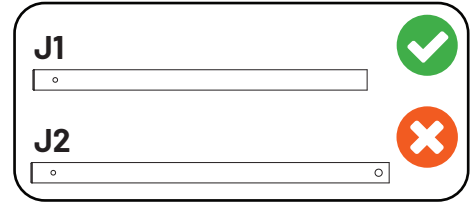
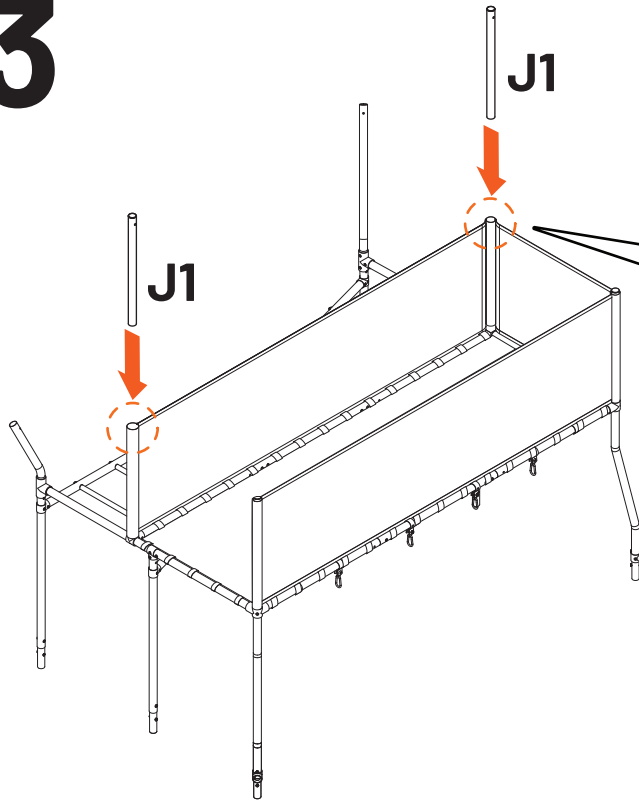

34

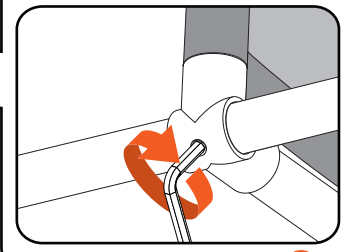
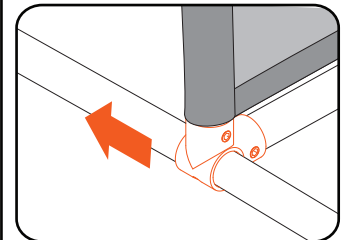
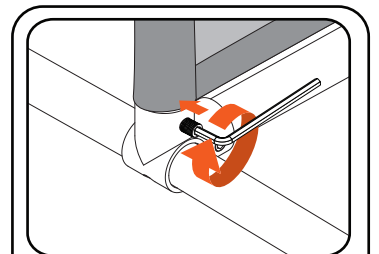
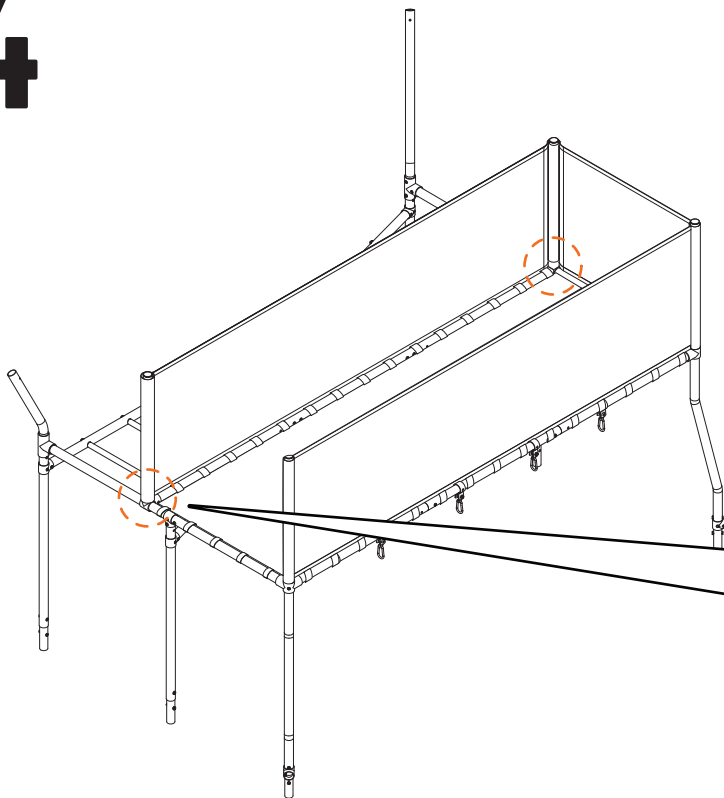

NOTE: Slide Joiners in direction of arrow to tension Hideout assembly, tighten Grub Screw to lock in place.



35

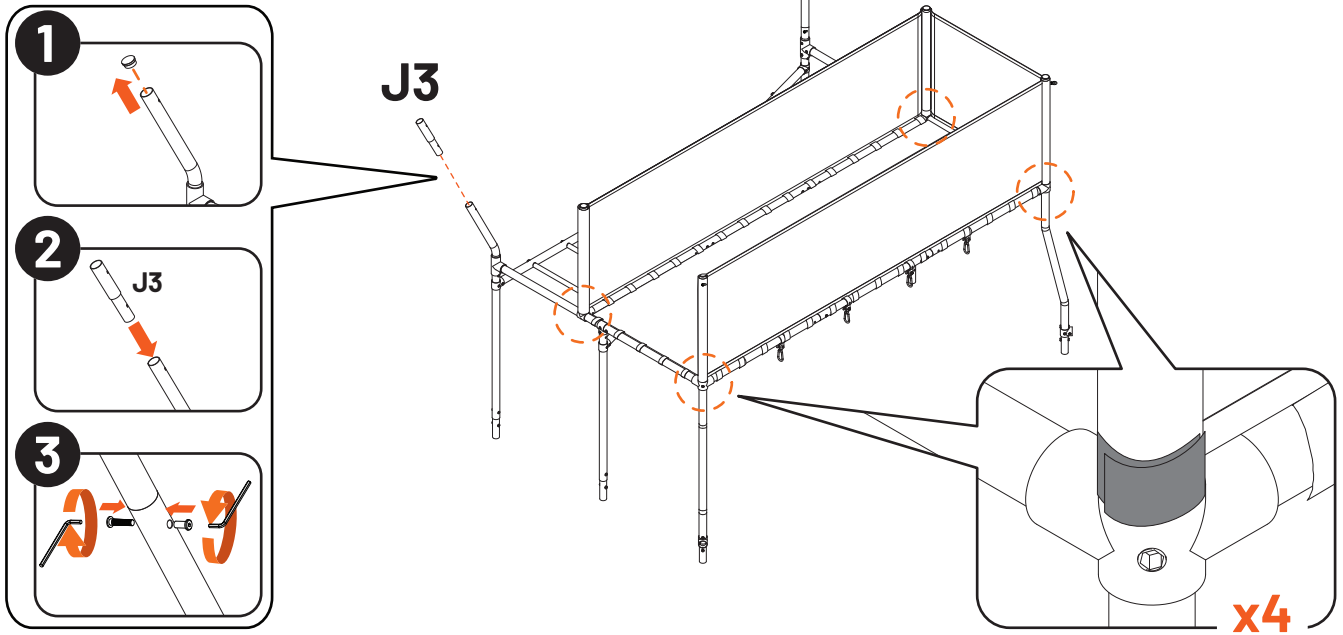

NOTE: Ensure all Velcro Straps on Safety Net are secured before proceeding to the next step.

36

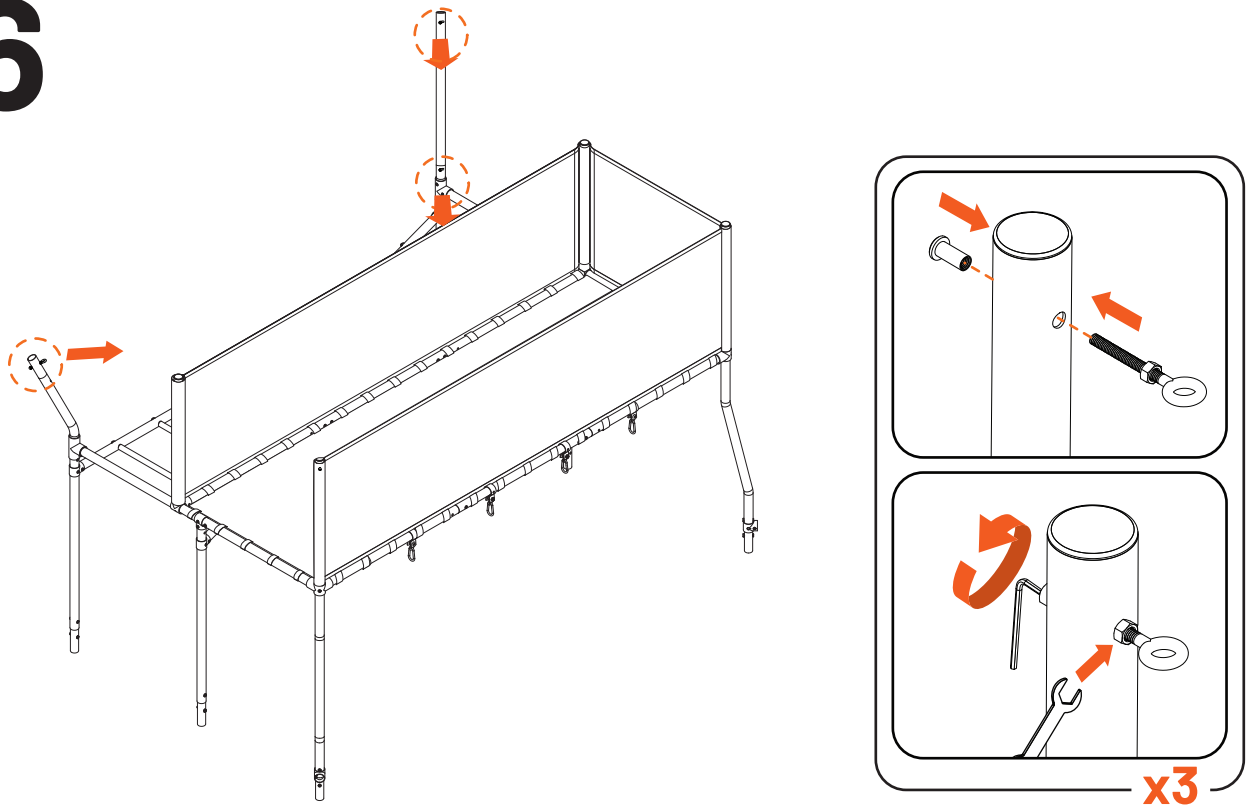

NOTE: Pay attention to direction of Eye Bolts.



37

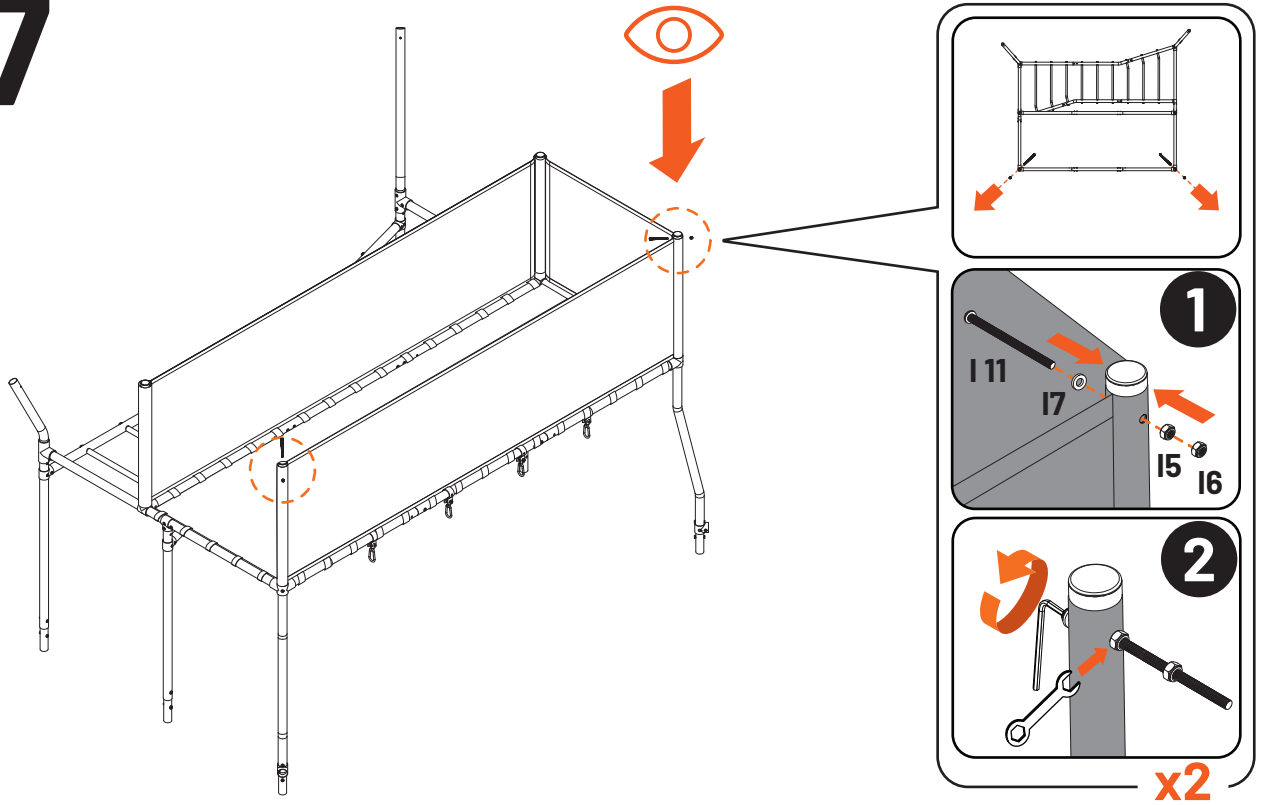

38

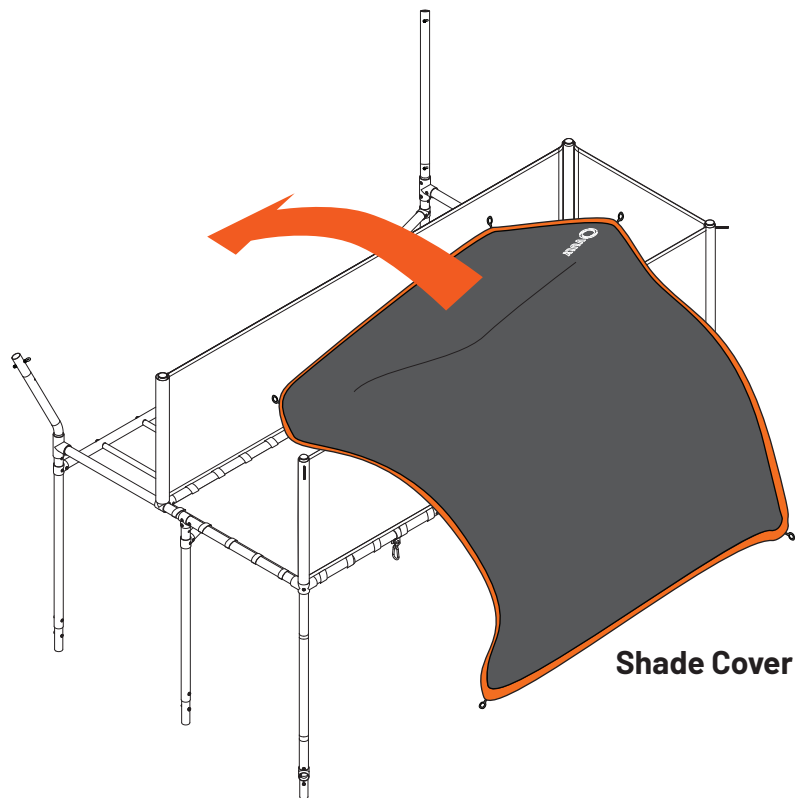

39

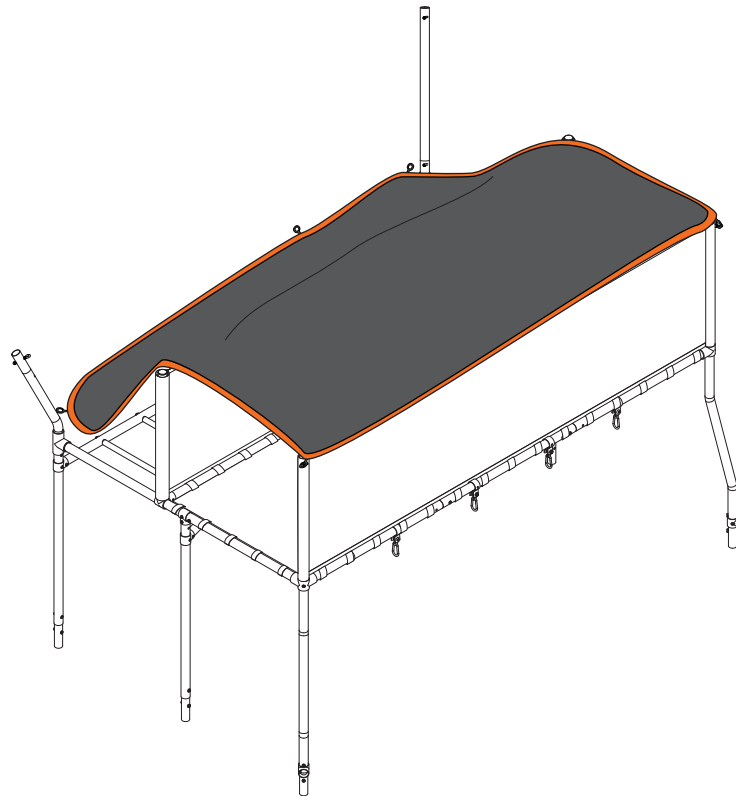
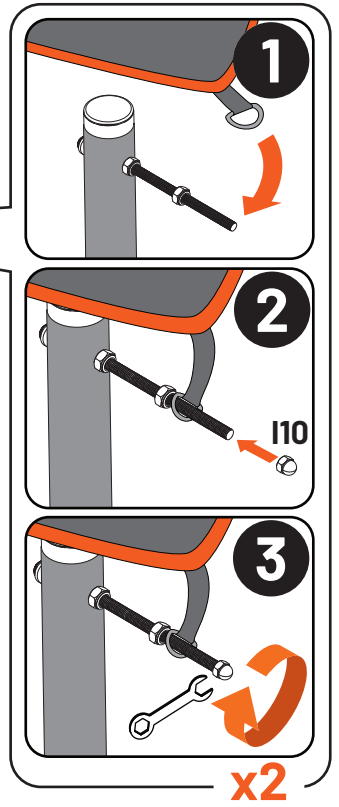
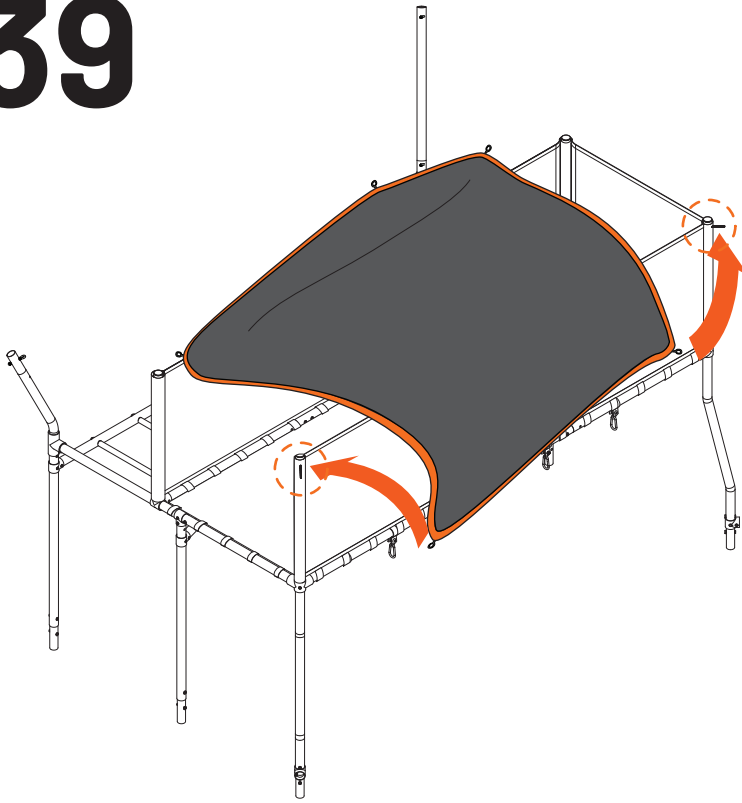

40

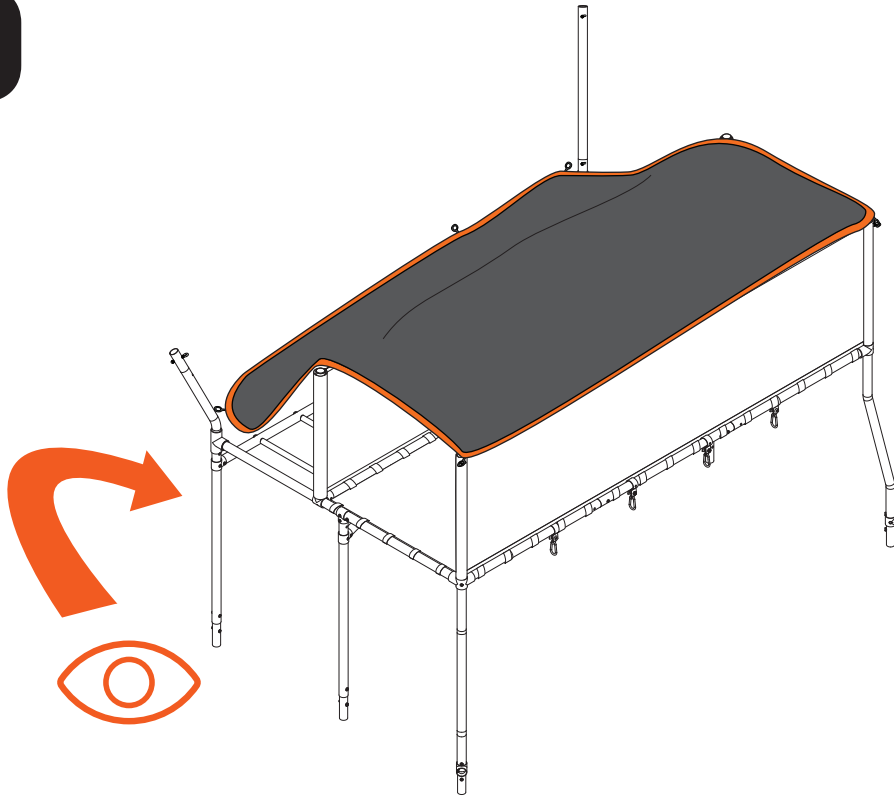

41

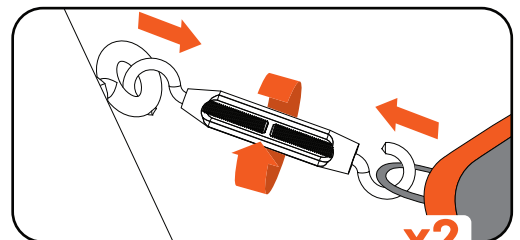
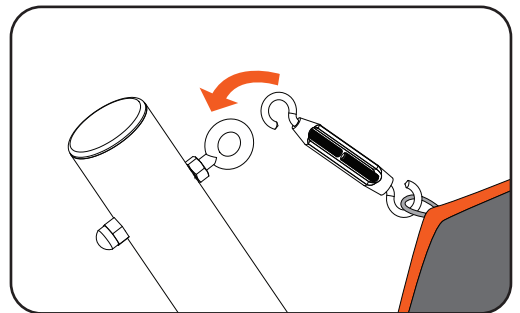
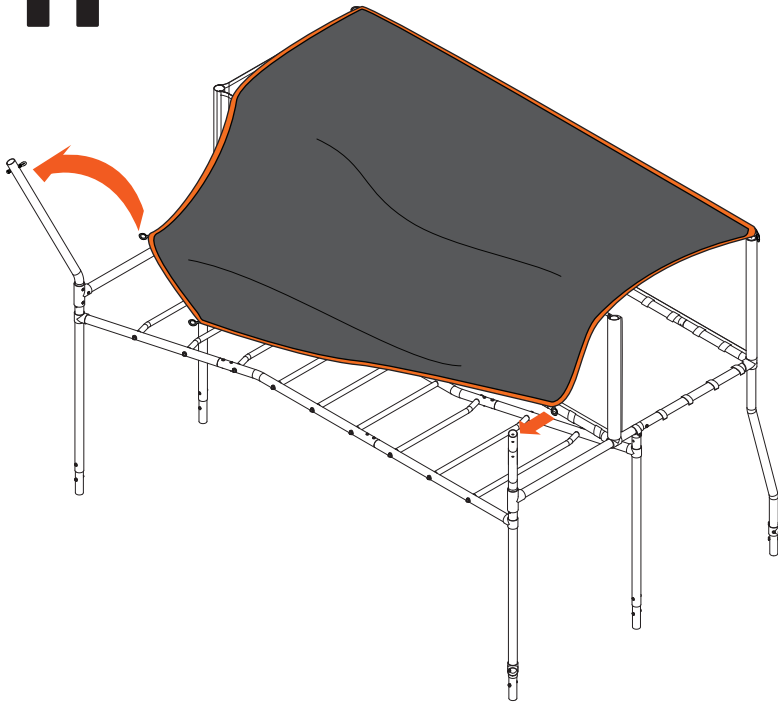

42

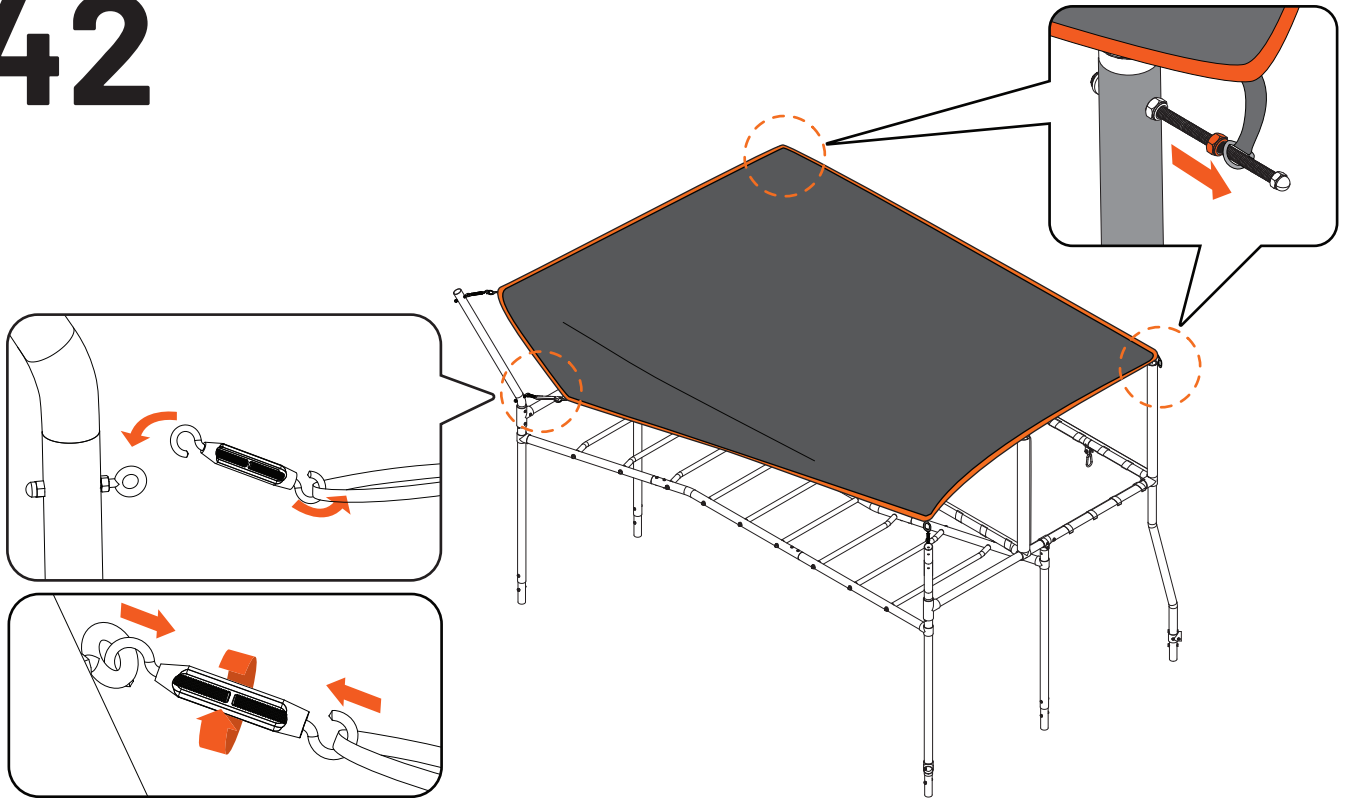

NOTE: Ensure Shade Cover is fully tensioned before proceeding to the next step.



43

OPTIONAL

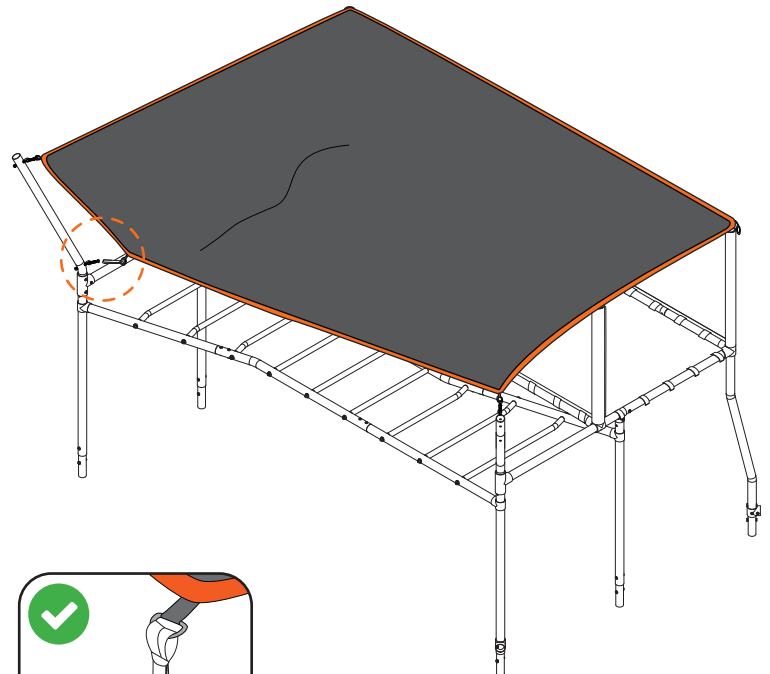
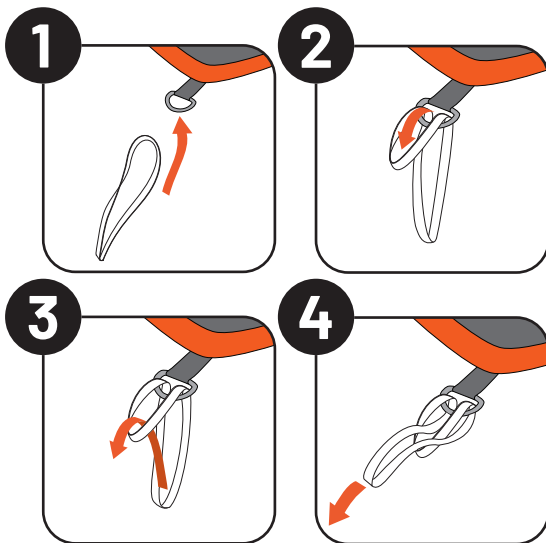

NOTE: If having difficulties connecting Turn Buckle to D Shackle, use the PP Webbing Loop provided as shown.



44 x3

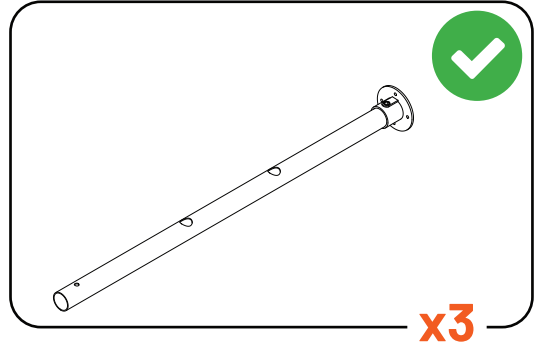
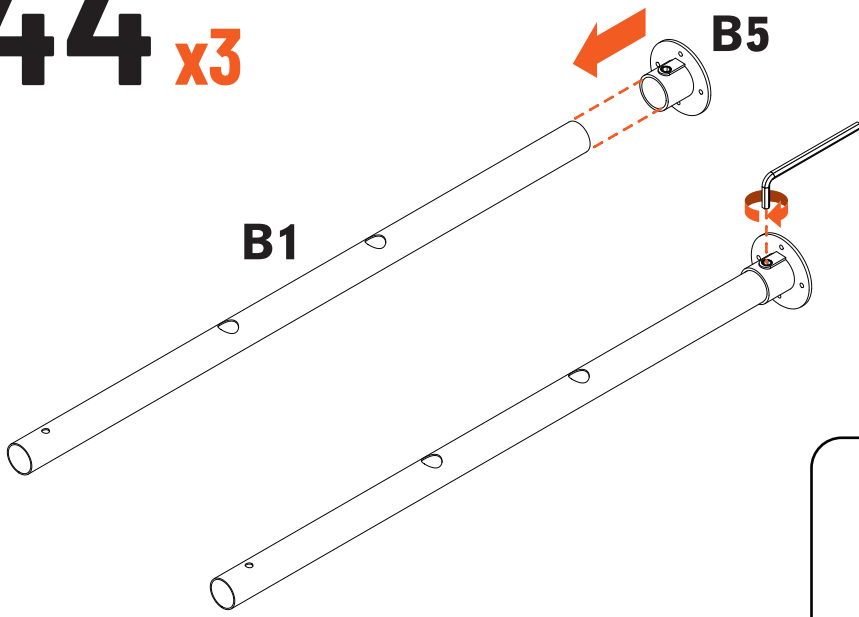

45 x1

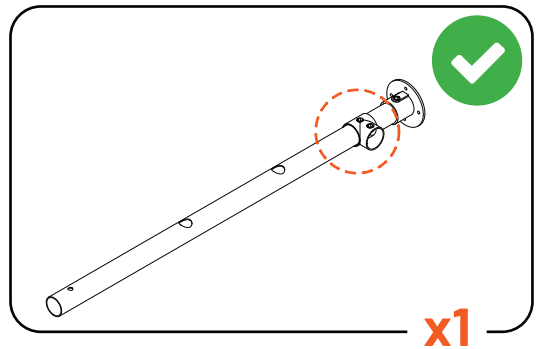
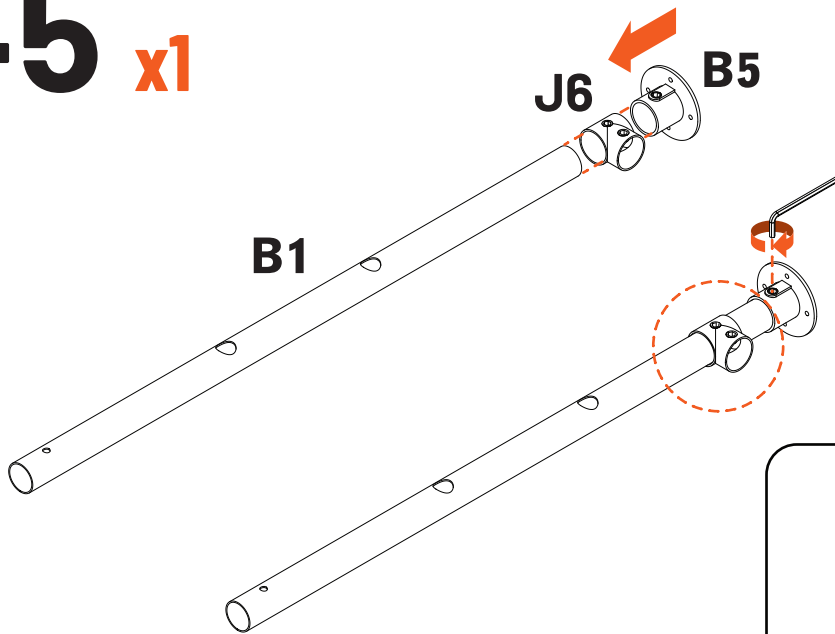

46

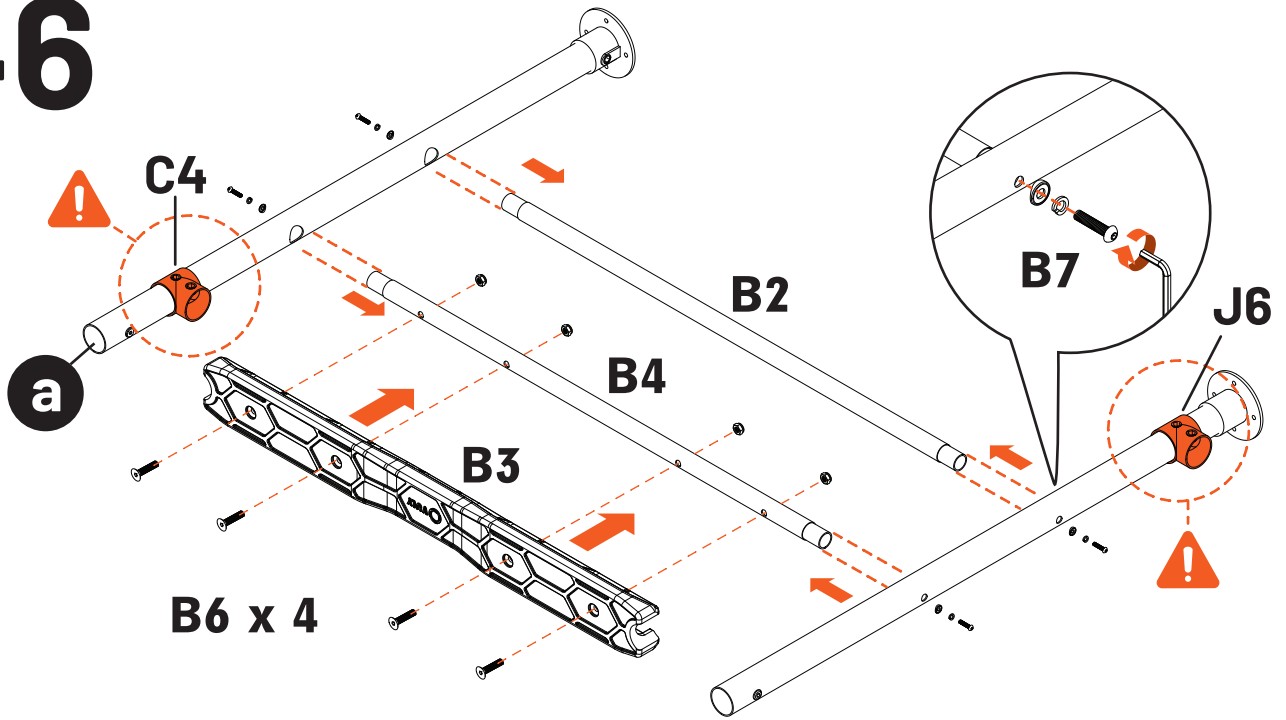

NOTE: Ensure this H Frame assembly includes Joiners as indicated.

47

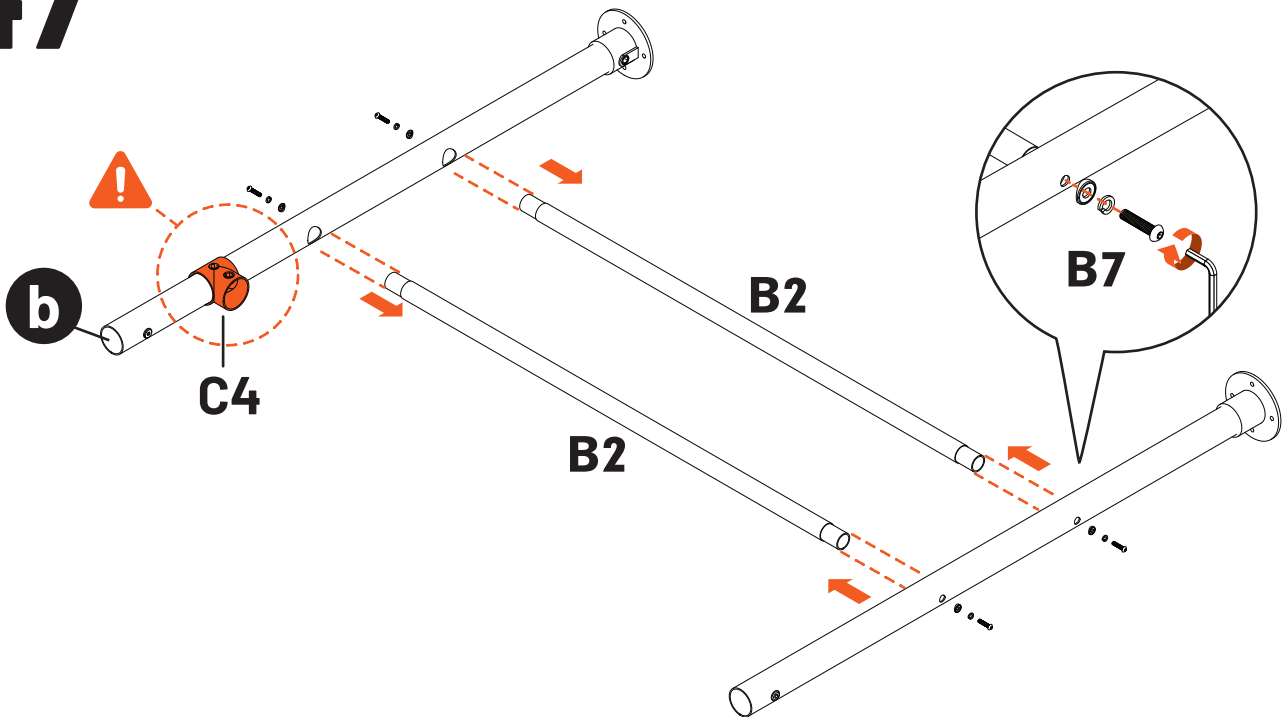

NOTE: If you don't have Cargo net accessory skip this step. Ensure this H Frame assembly includes Joiners as indicated.



48

OPTIONAL

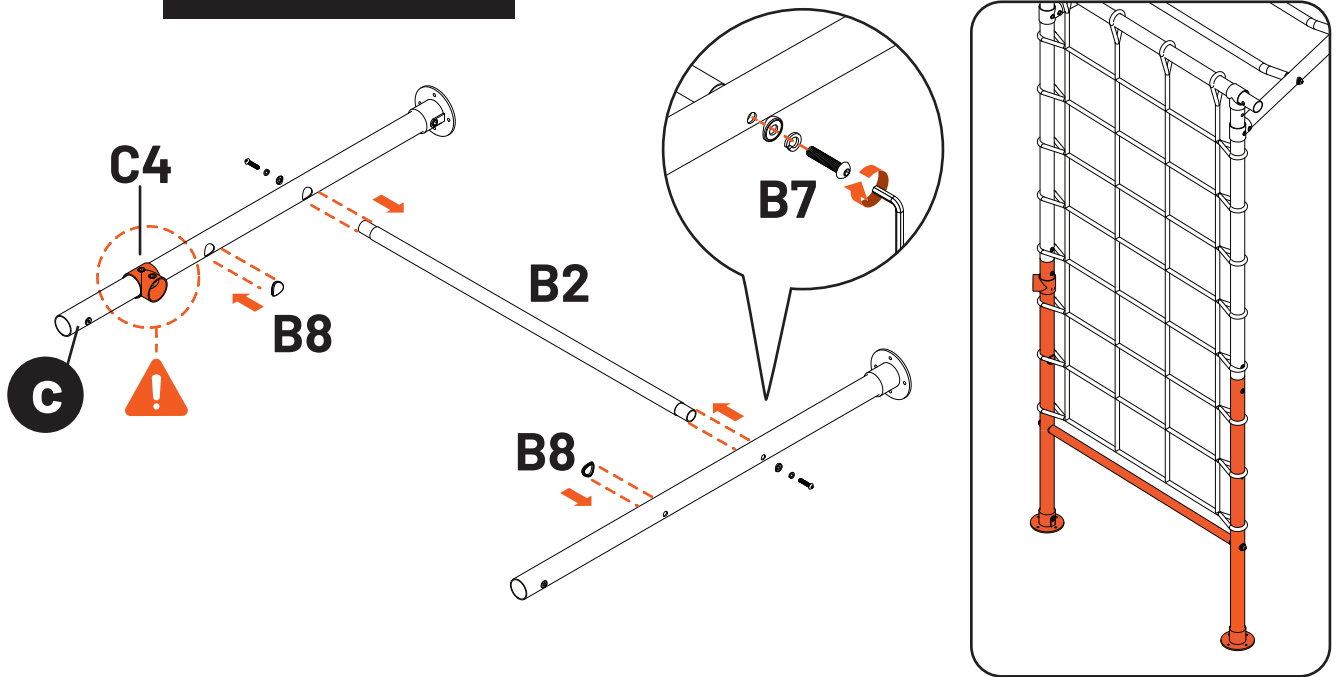

NOTE: If you don't have Cargo net accessory skip this step. Ensure this H Frame assembly includes Joiners as indicated.



49

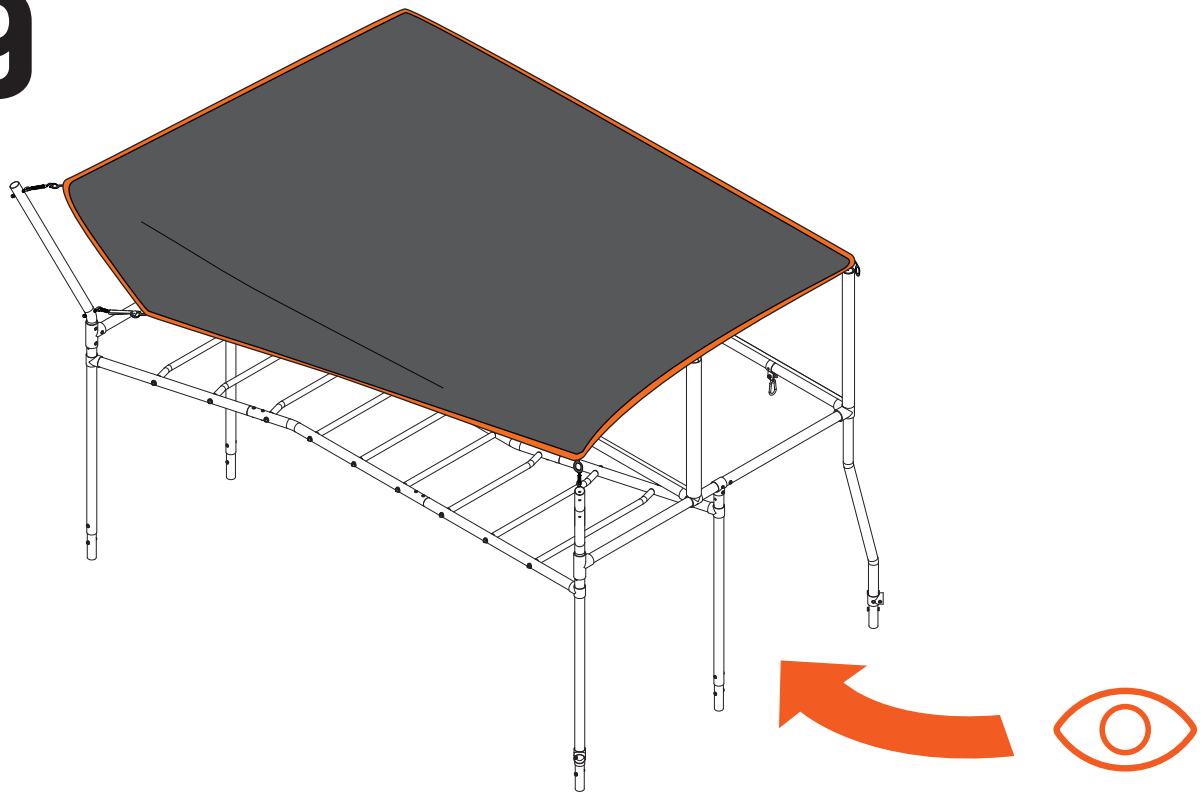

50

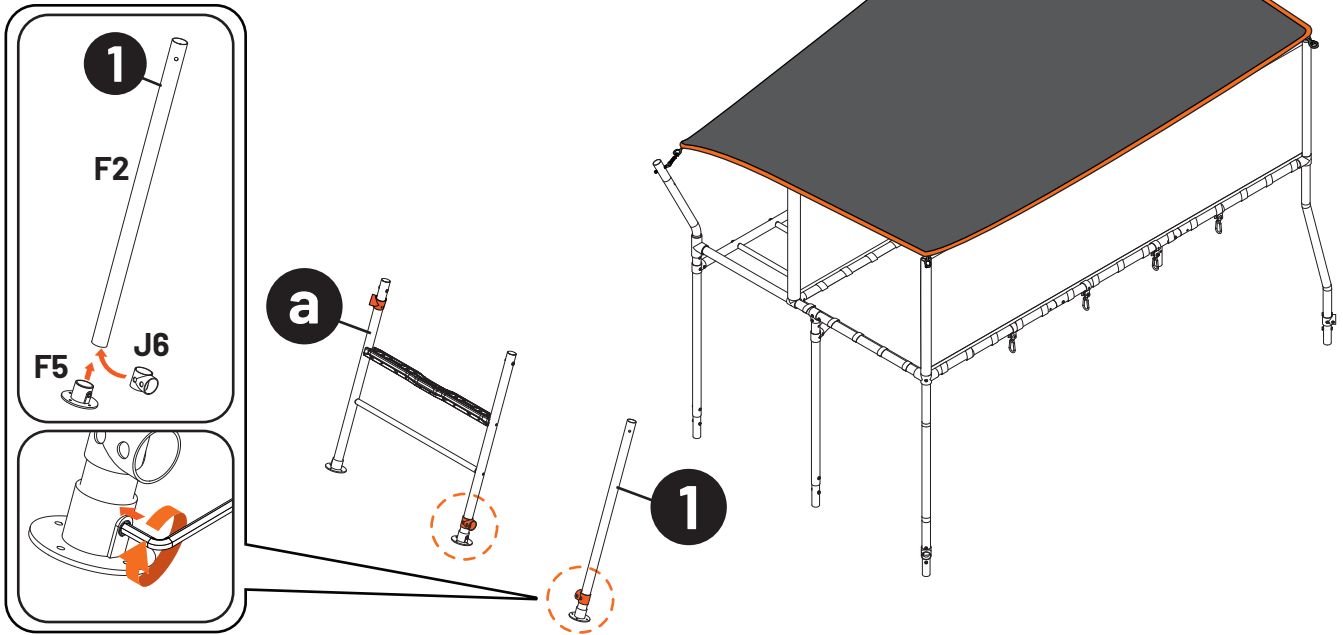

NOTE: Ensure J6 Joiners are positioned as shown.



51

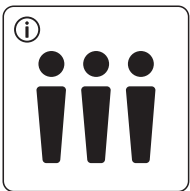
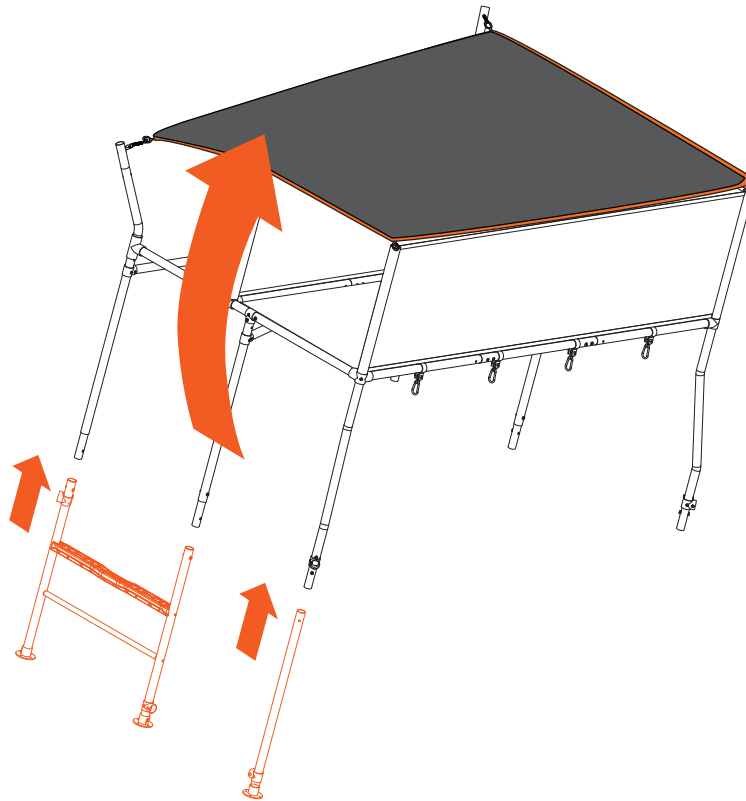

WARNING! Minimum of three people required for this step. Lift with straight back!



52

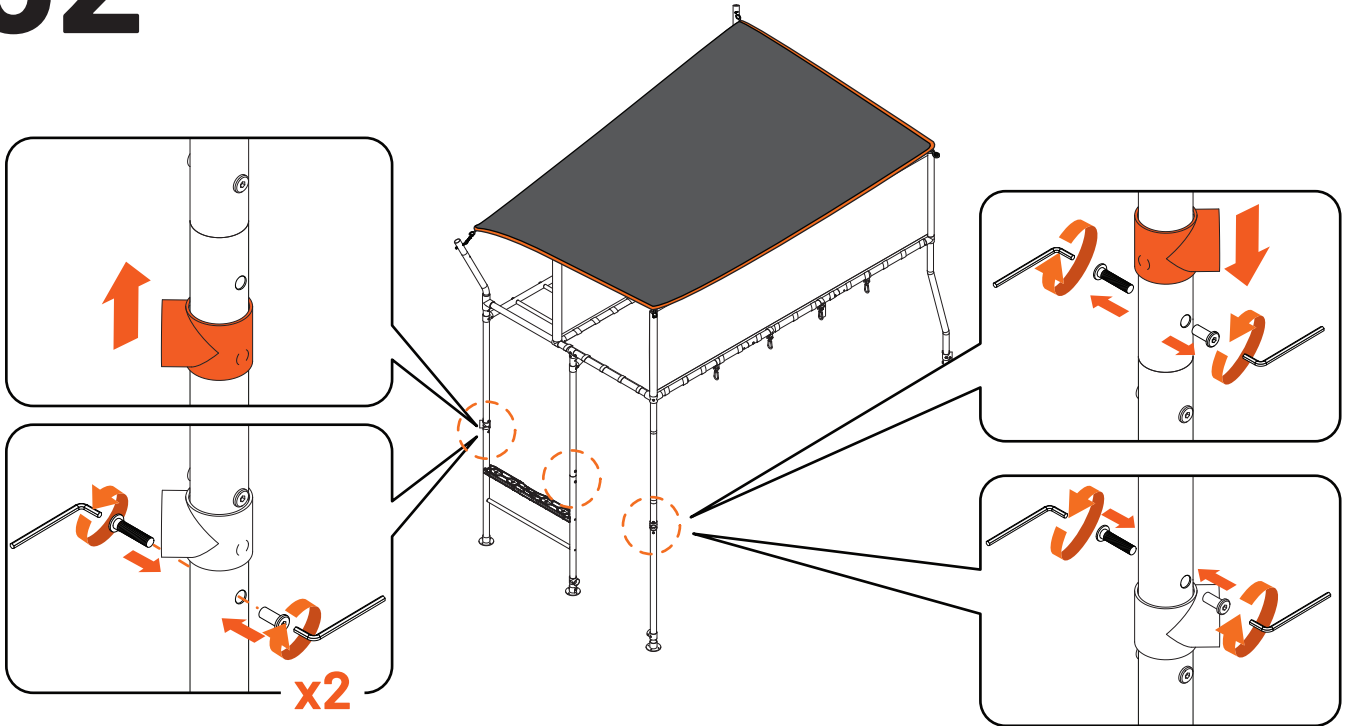

WARNING! Ensure Joiners are located in between the two Frame Bolts.



53

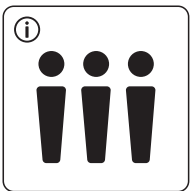
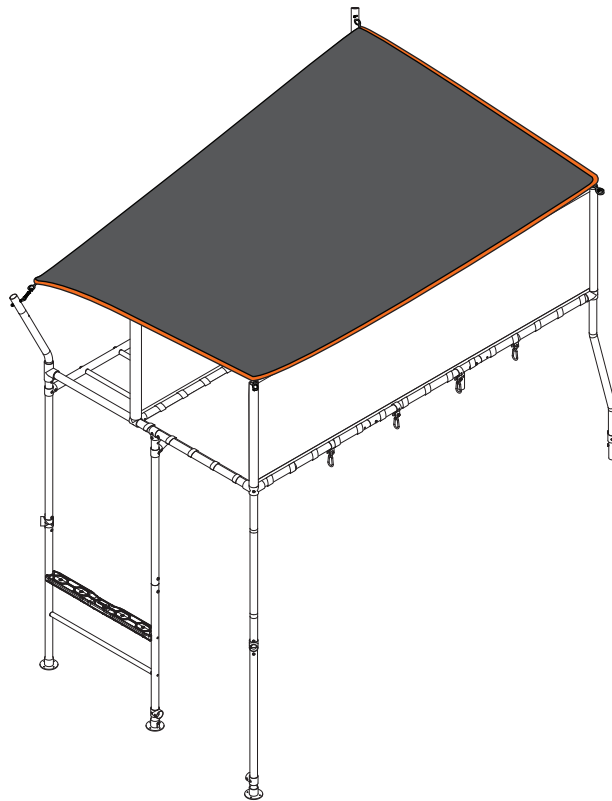

WARNING! Minimum of three people required for this step. Lift with straight back!



54

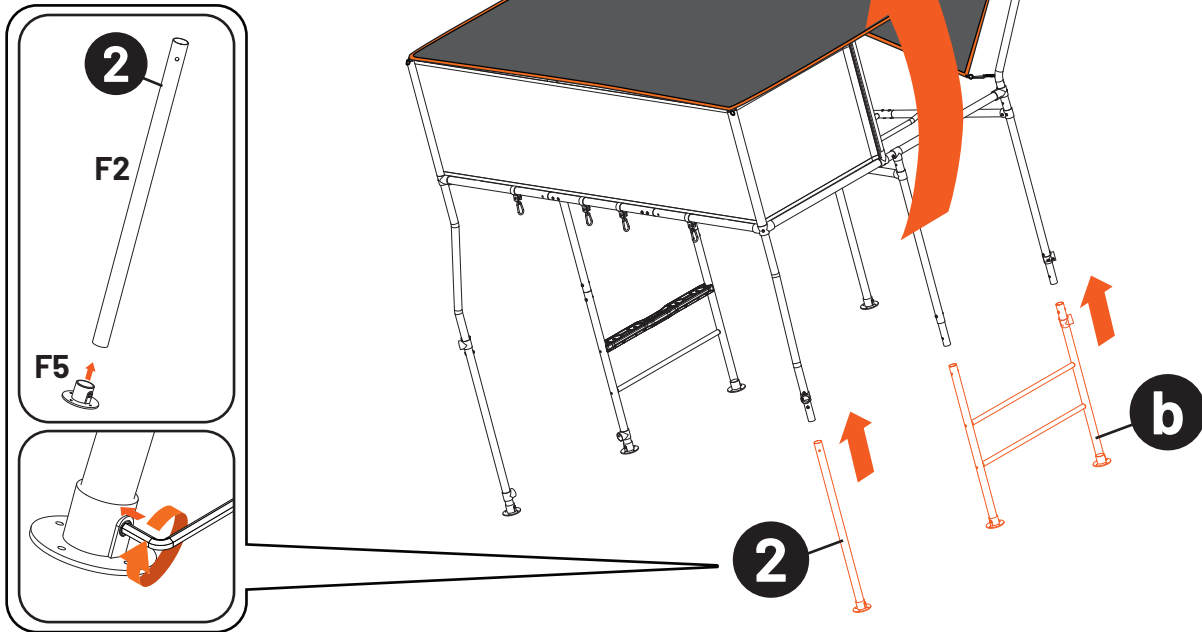

WARNING! Minimum of three people required for this step. Lift with straight back!

55

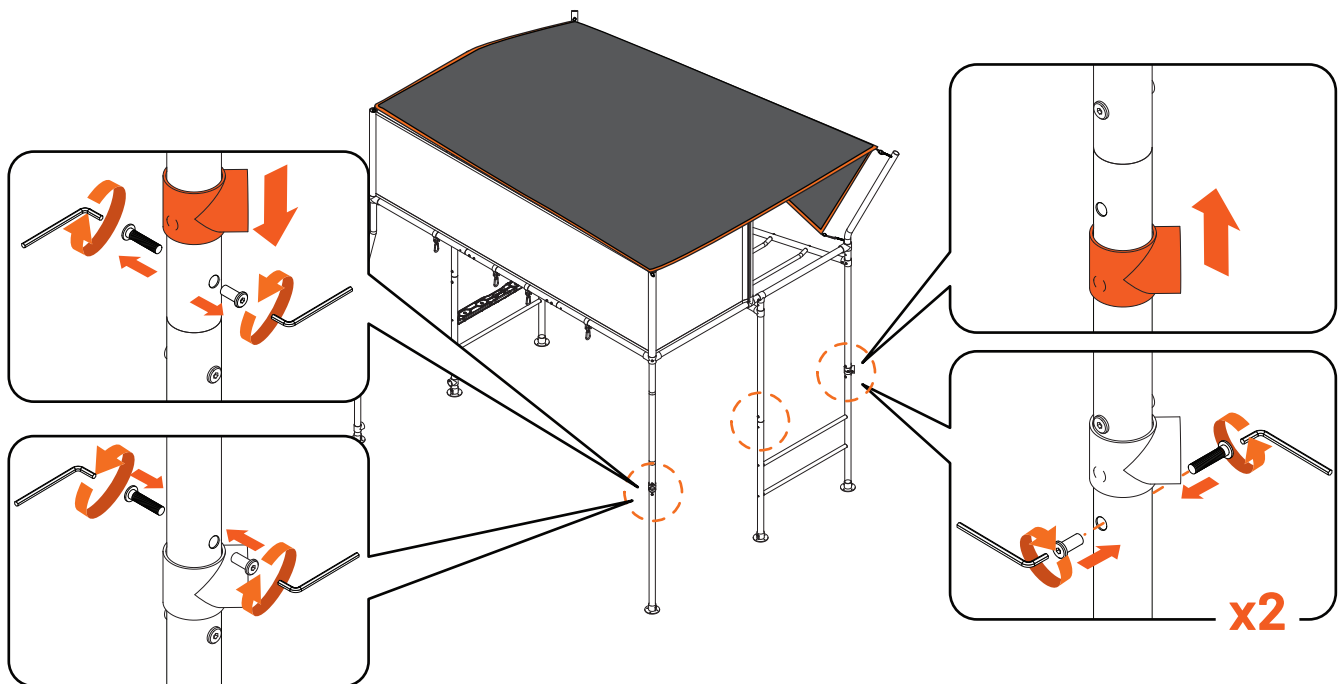

WARNING! Ensure Joiners are located in between the two Frame Bolts.



56

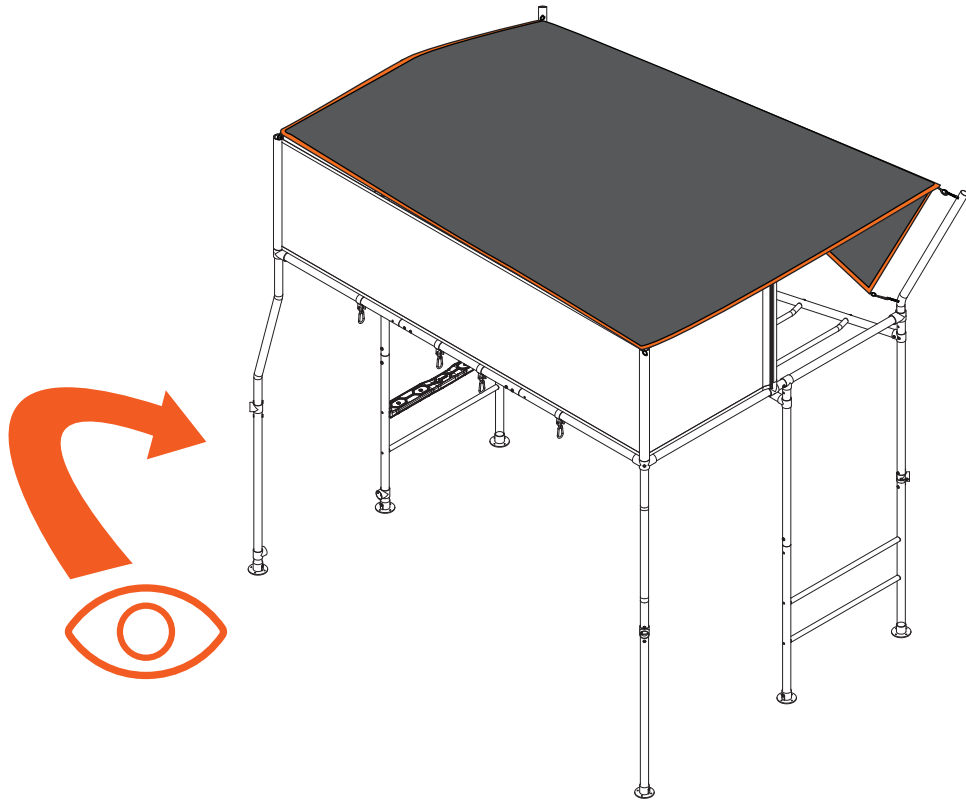

57

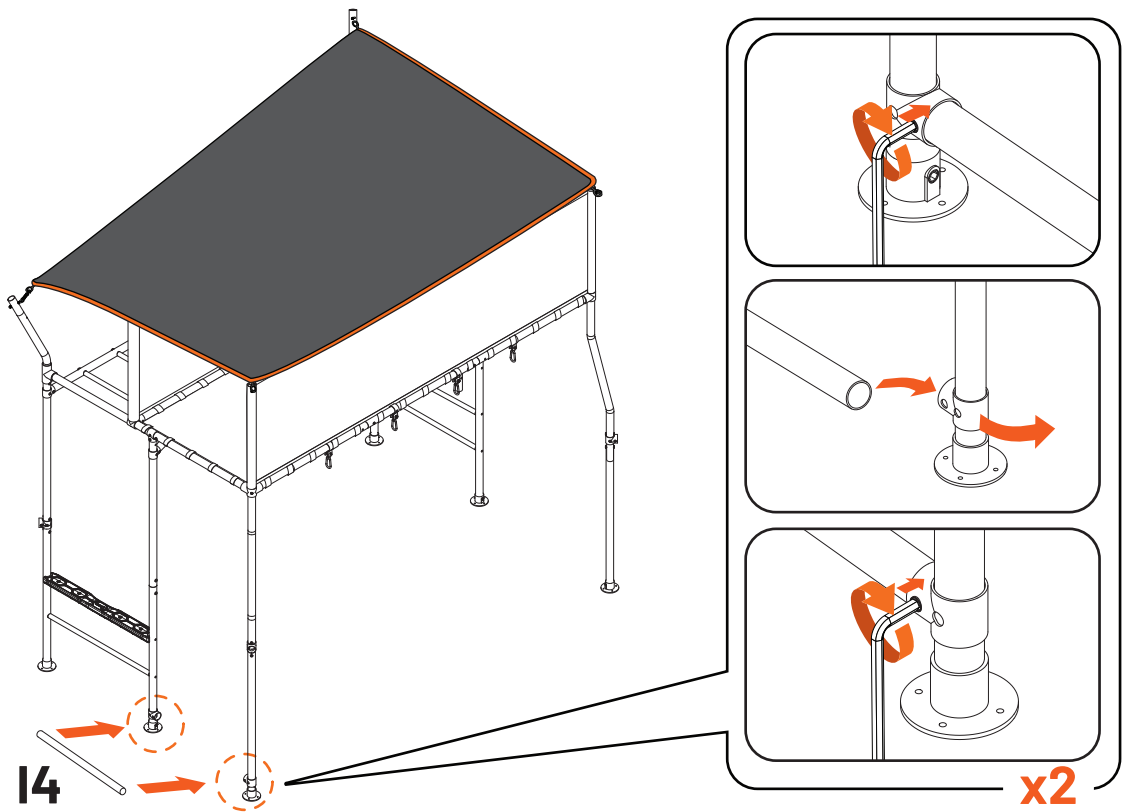

58 x4

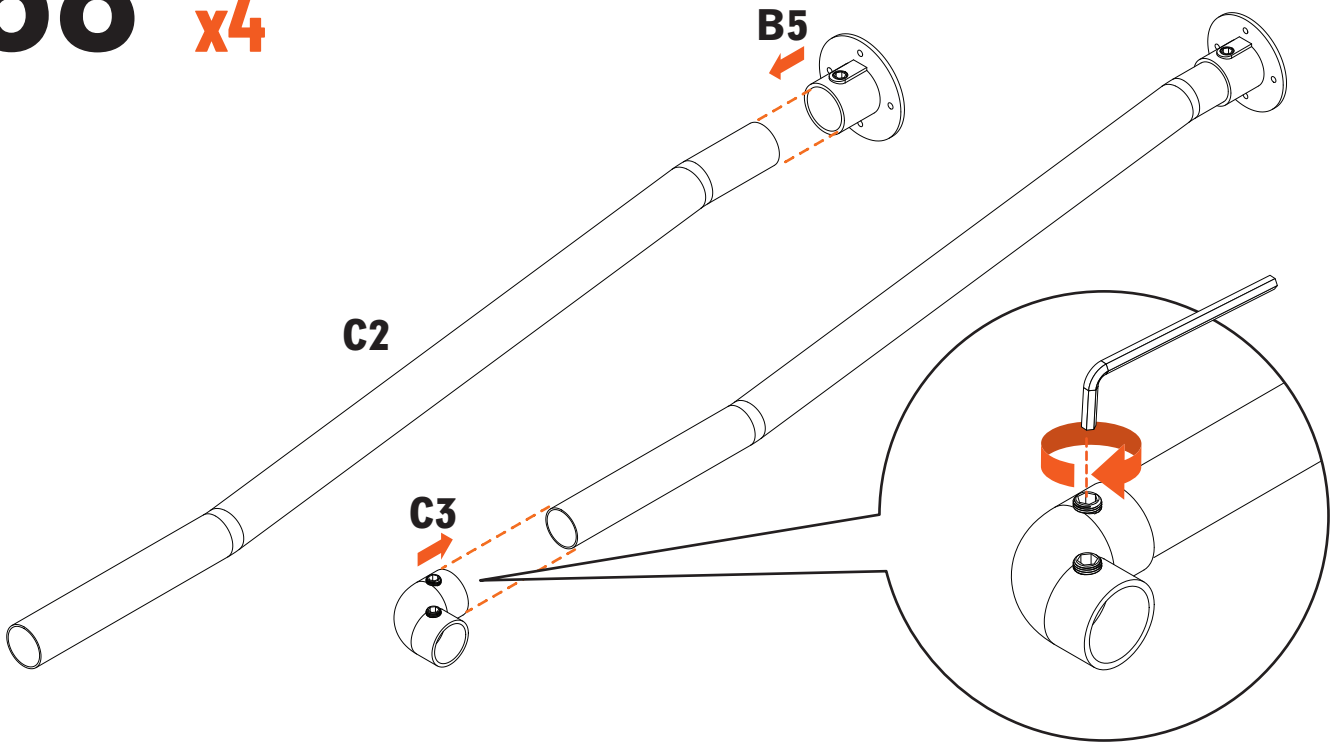

59 x4

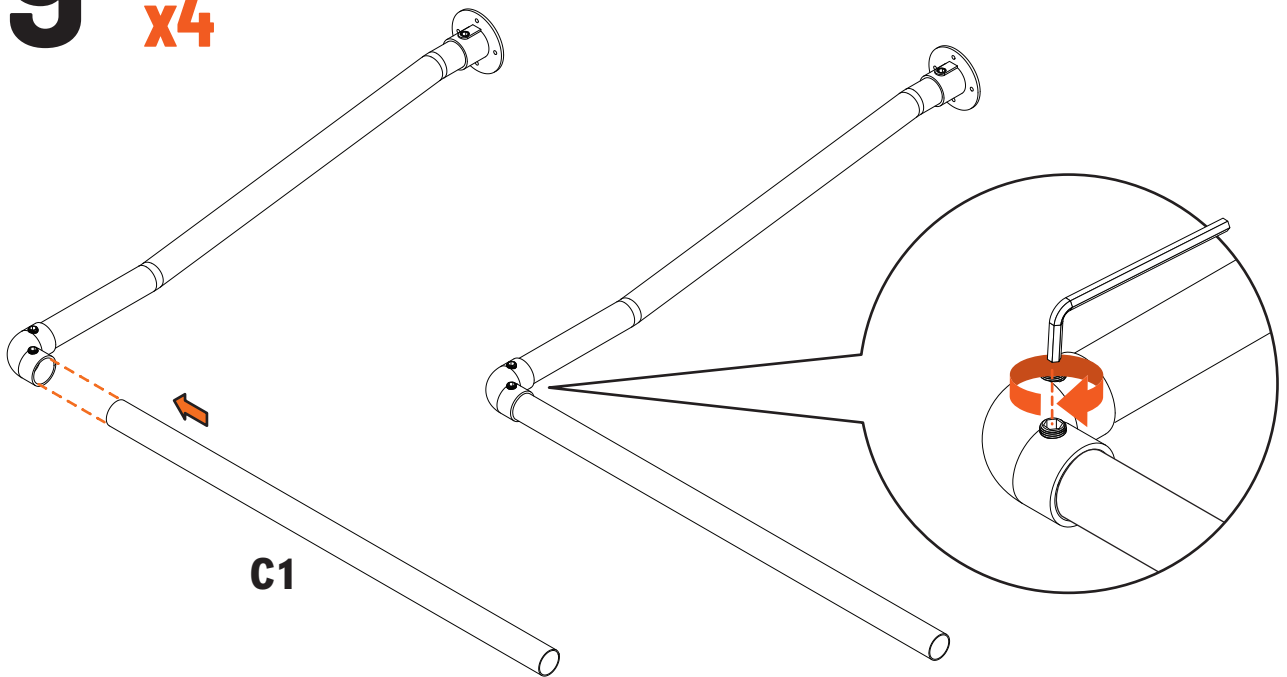

60

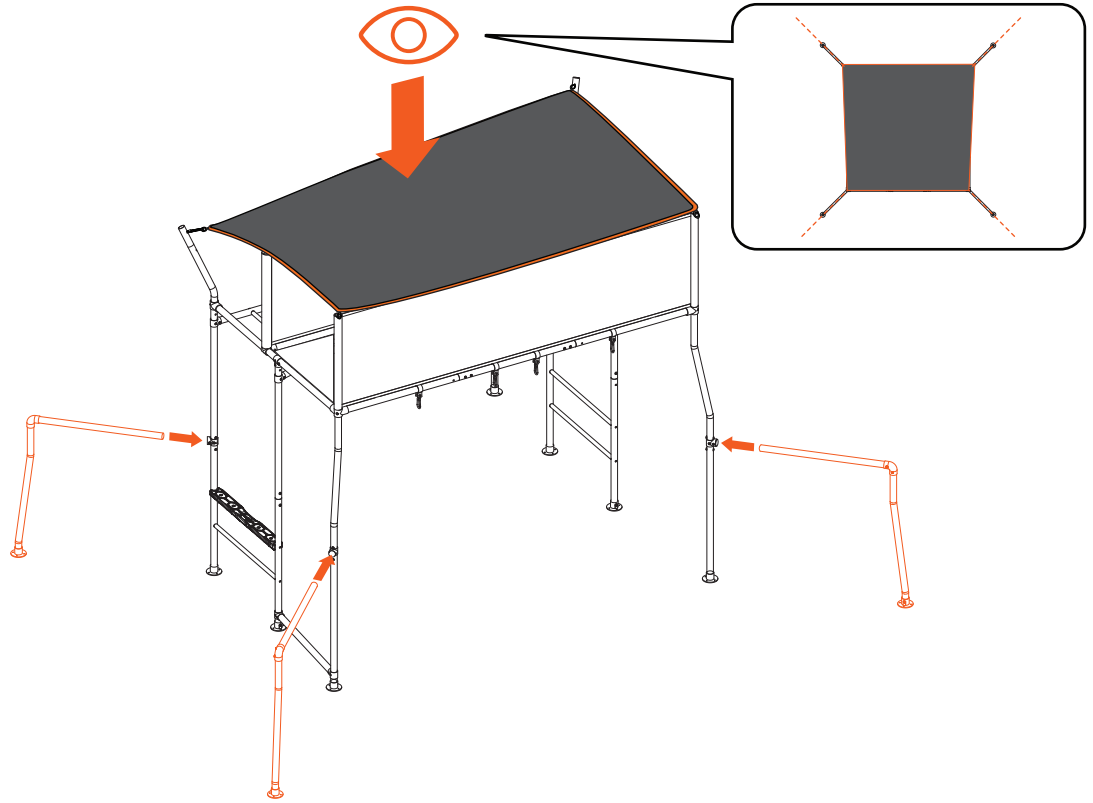

61

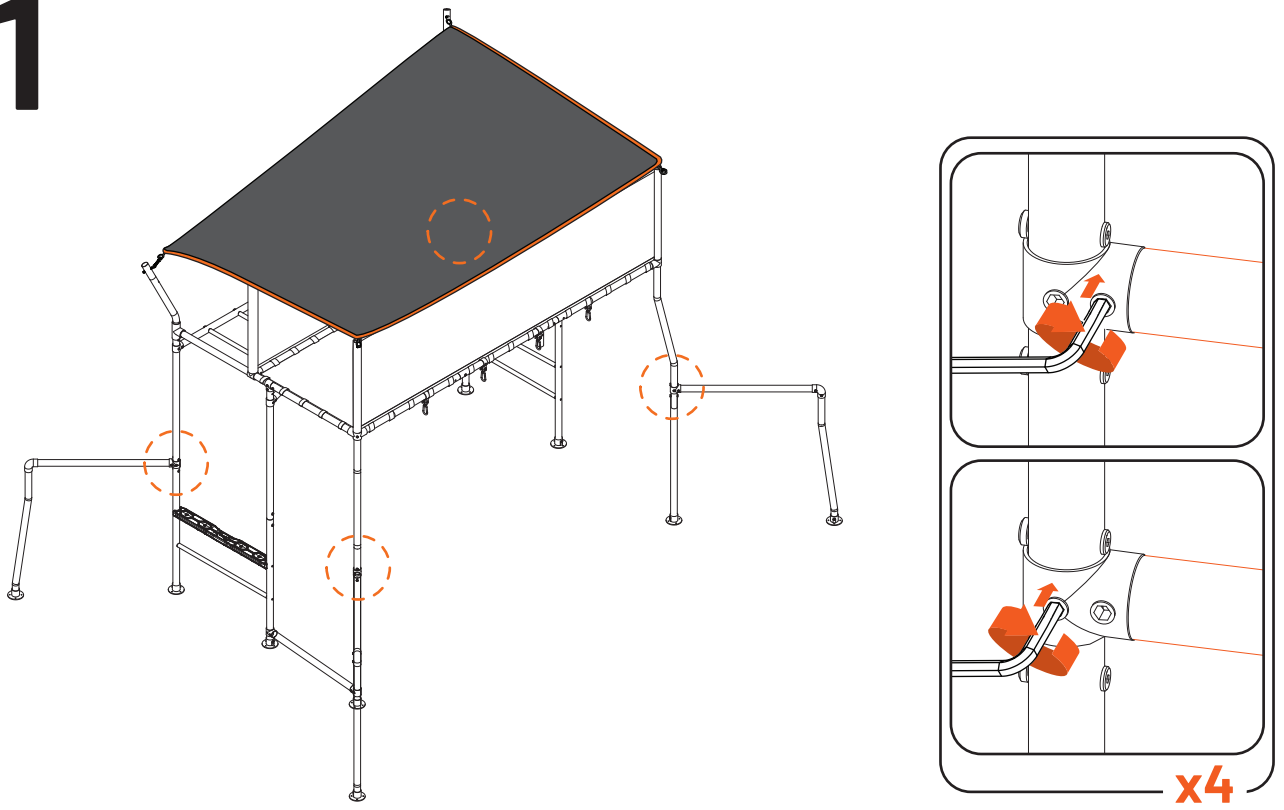

62

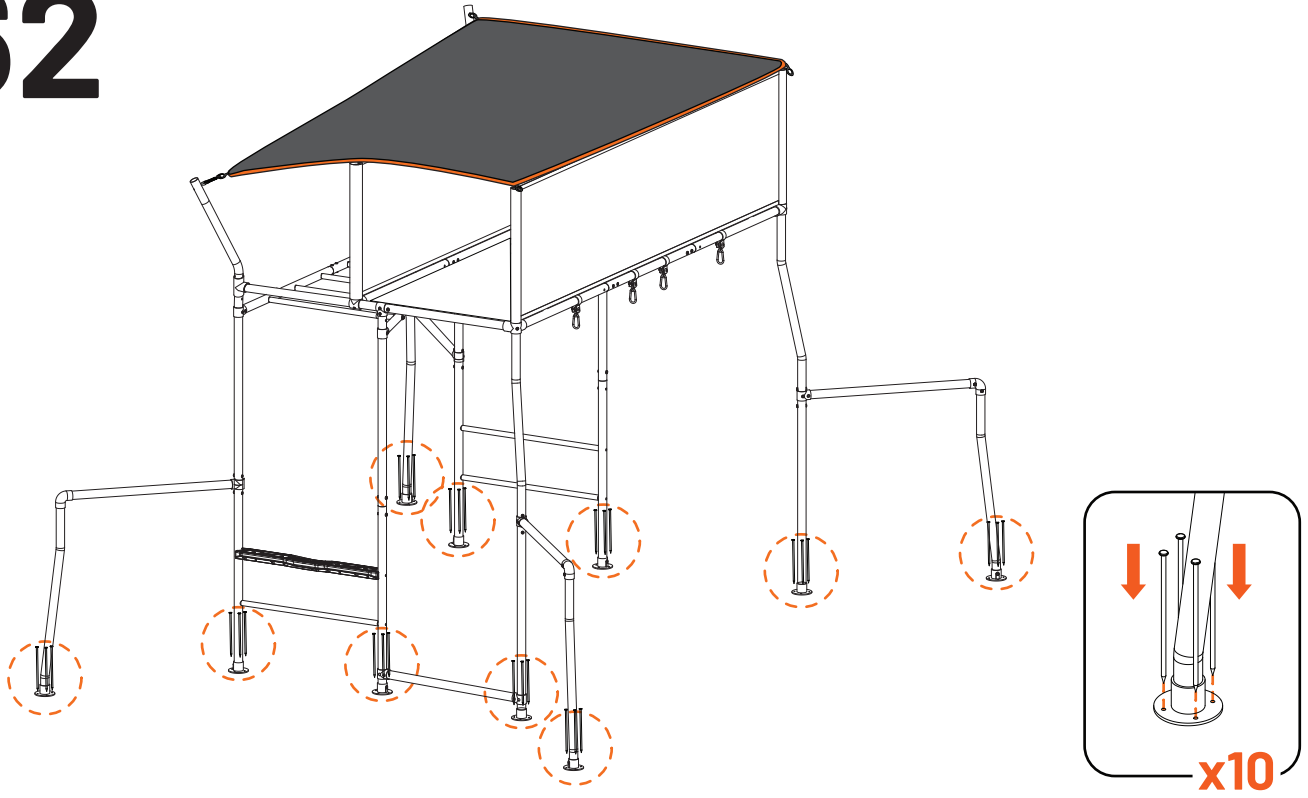

NOTE: Use new soil to anchor the playset once complete installation.



63

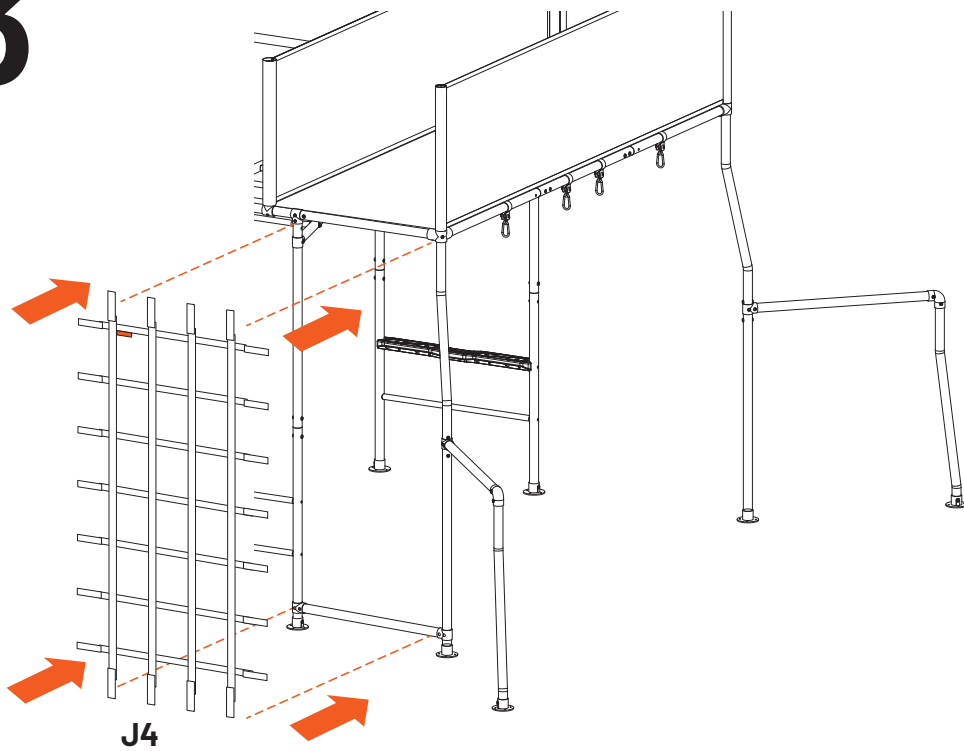

64

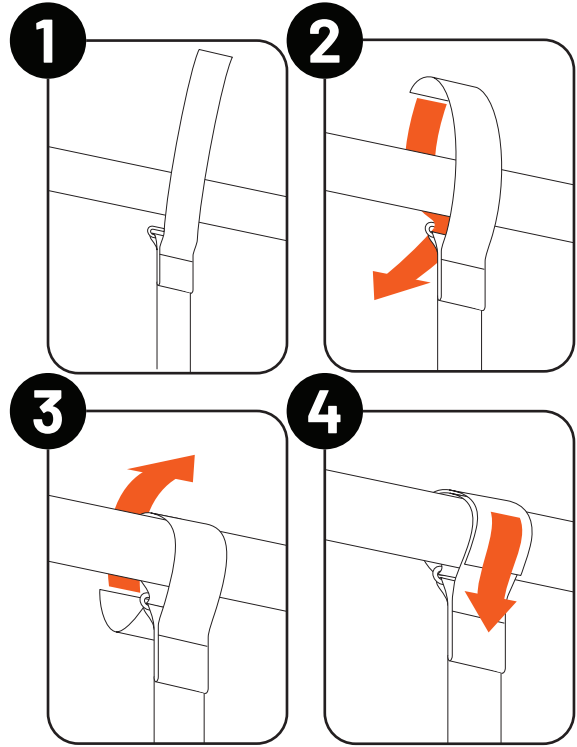
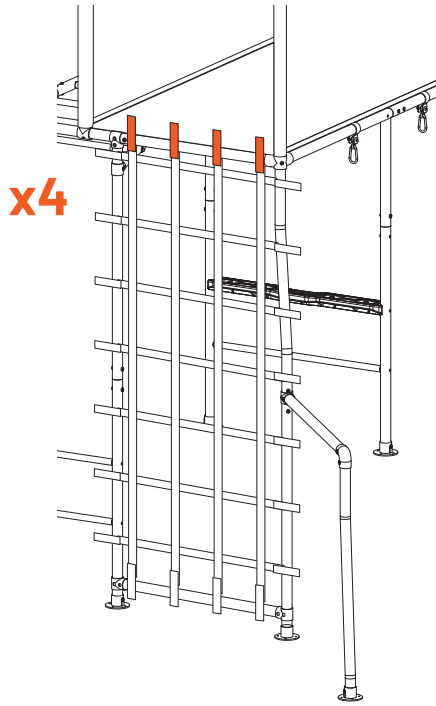

65

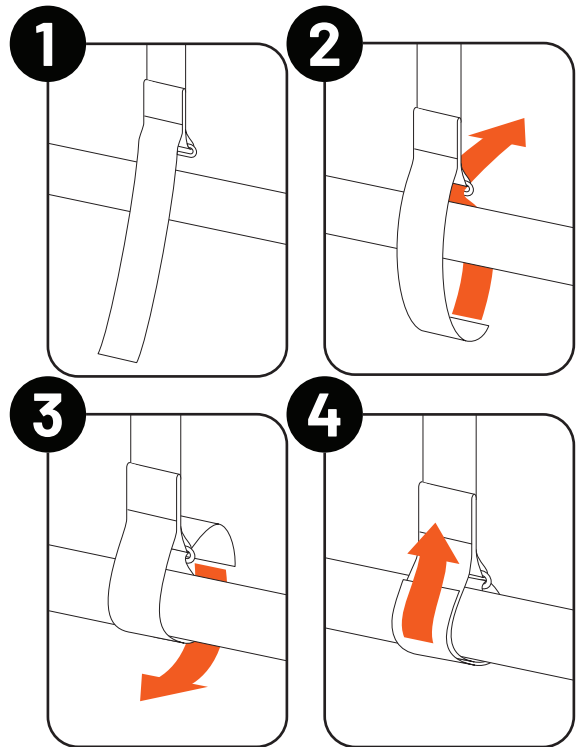
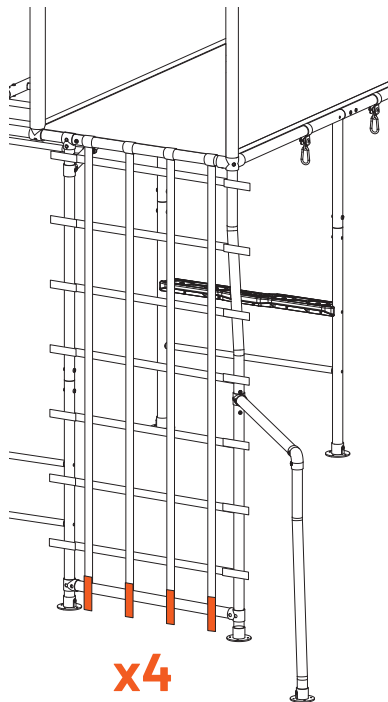

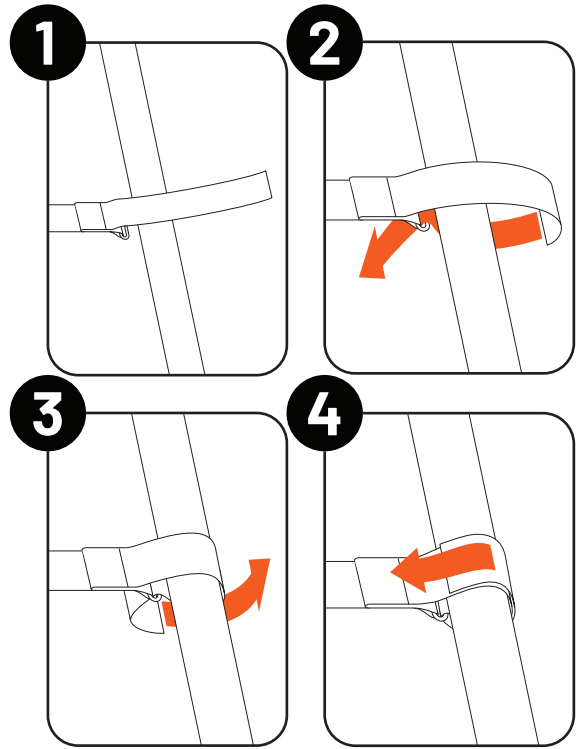
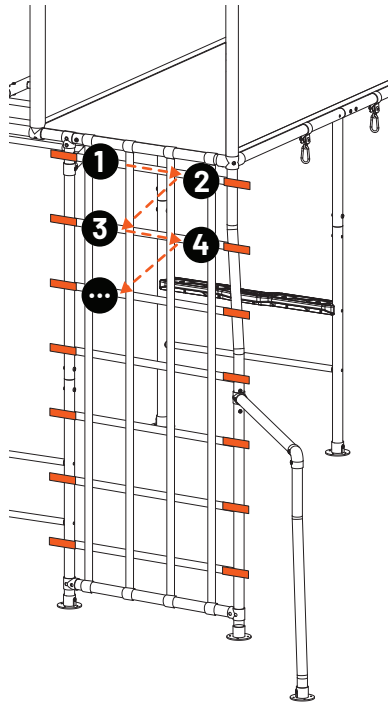

66

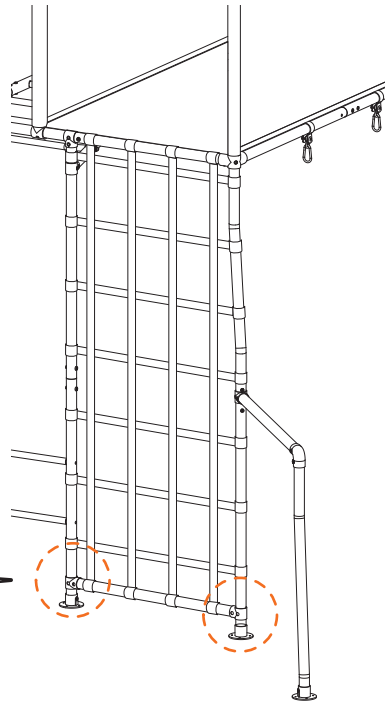
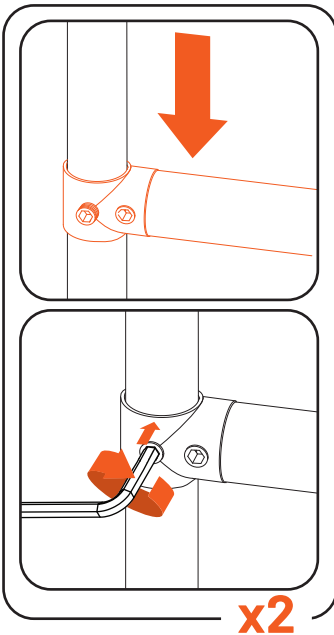

67



 **NOTE:** Tension Cargo Net by push down on Joiners, then tighten Grub Screw to secure the assembly. 



CONGRATULATIONS!

You have assembled your Quest 1 Pro playset!



4.2. Retrofit Assembly Instructions



NOTE: Always use a ladder throughout the entire assembly process for safety.



1

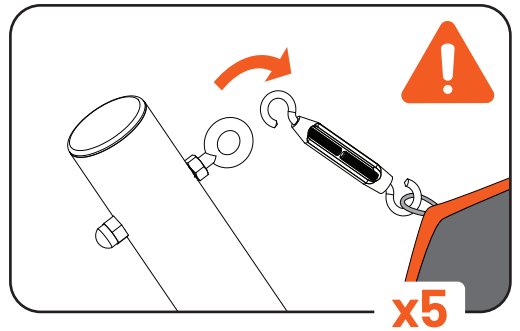
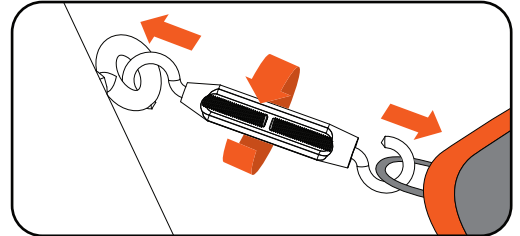
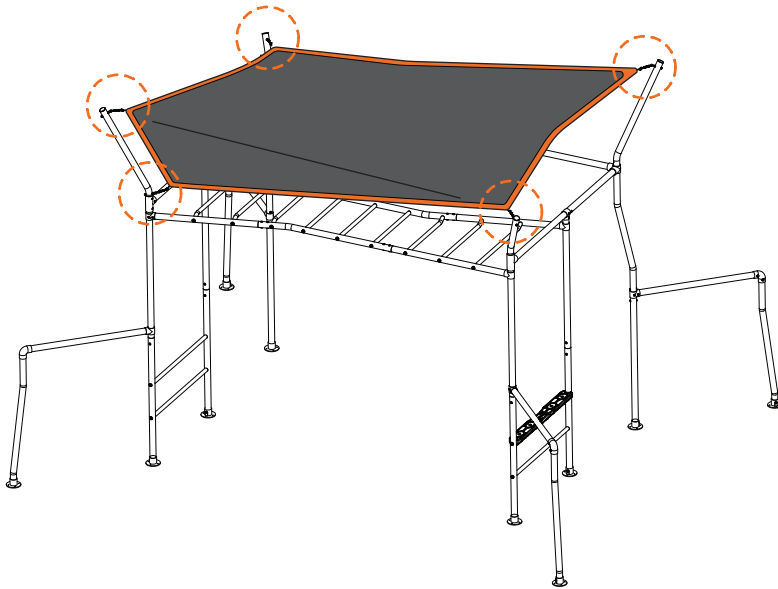

2

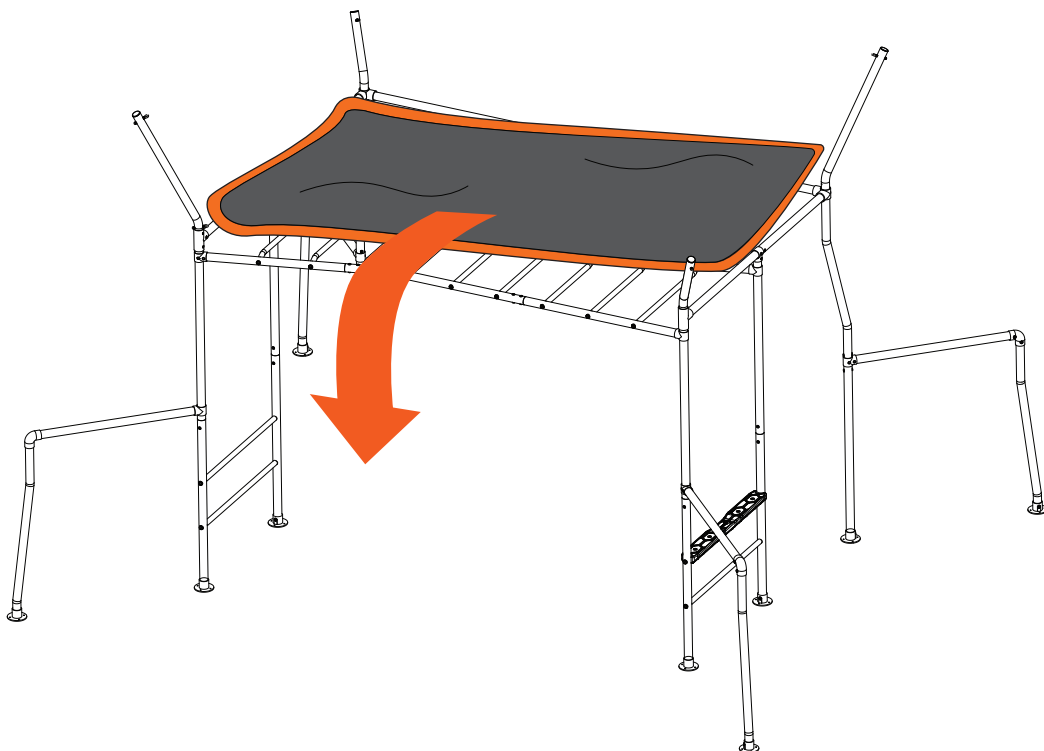

3

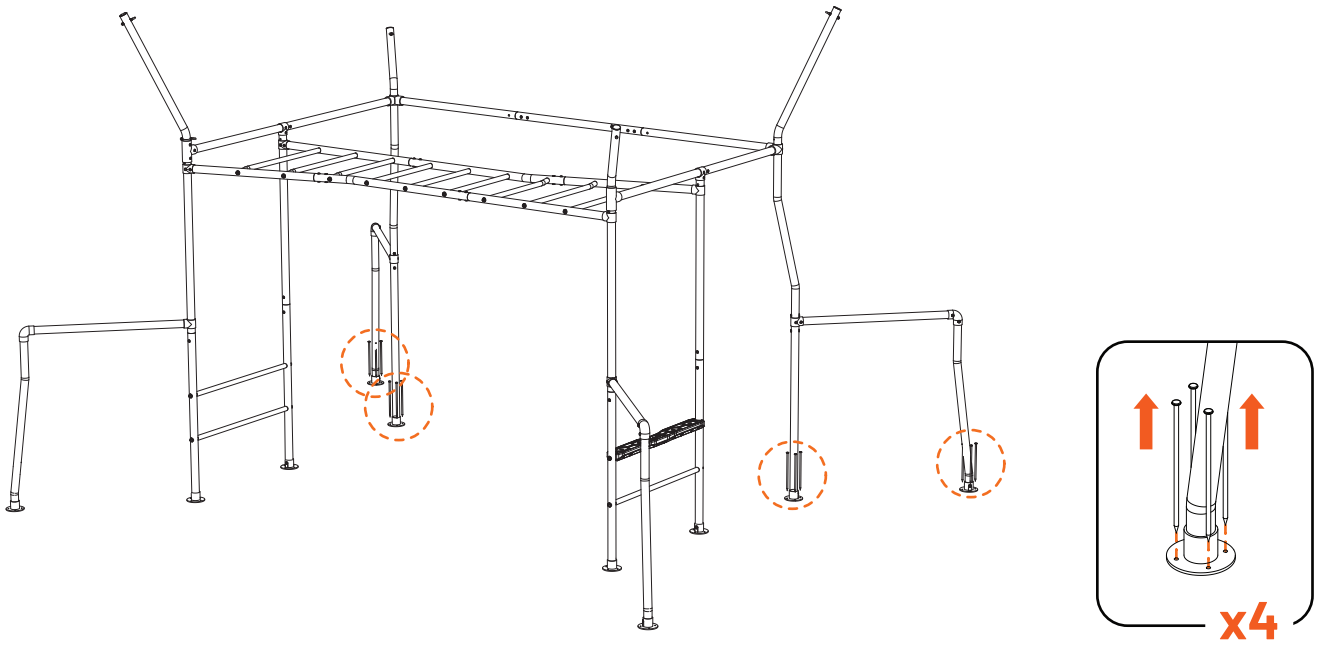

4

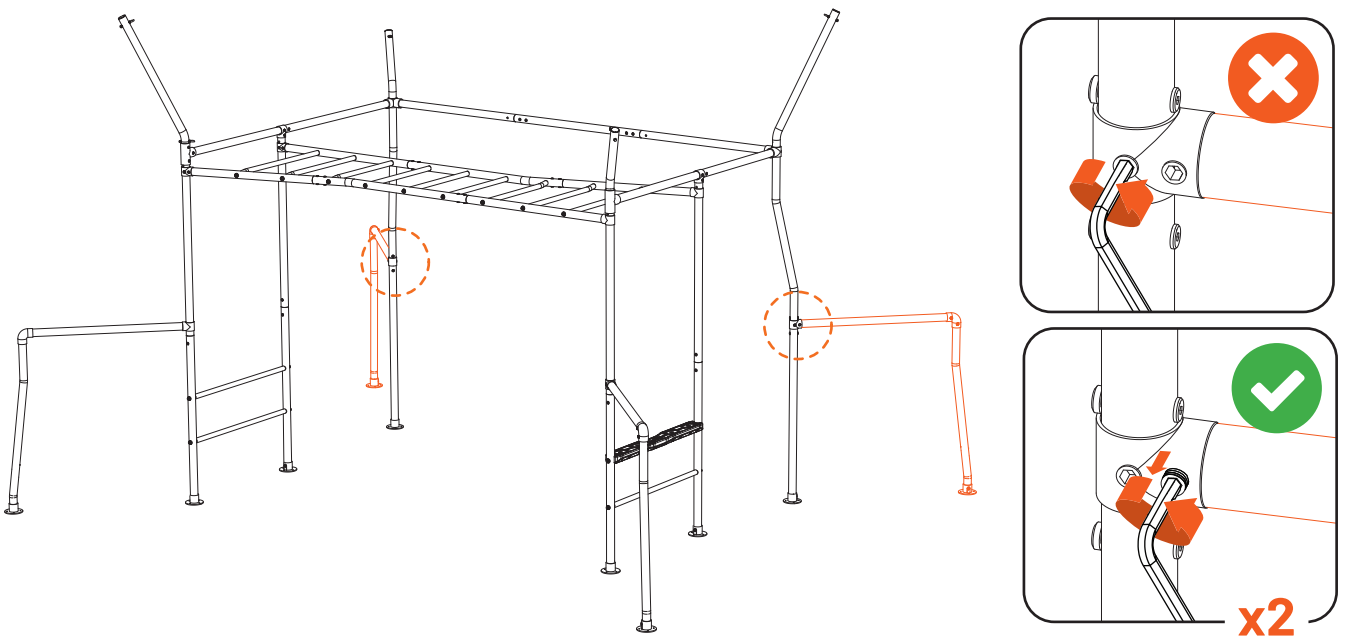



NOTE: Only loosen Grub Screw enough to remove tube.

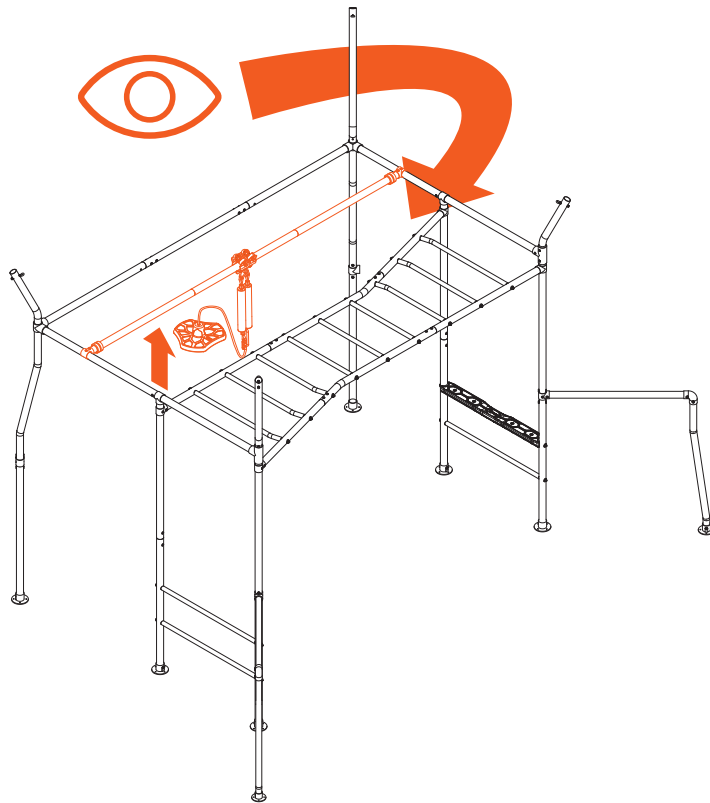
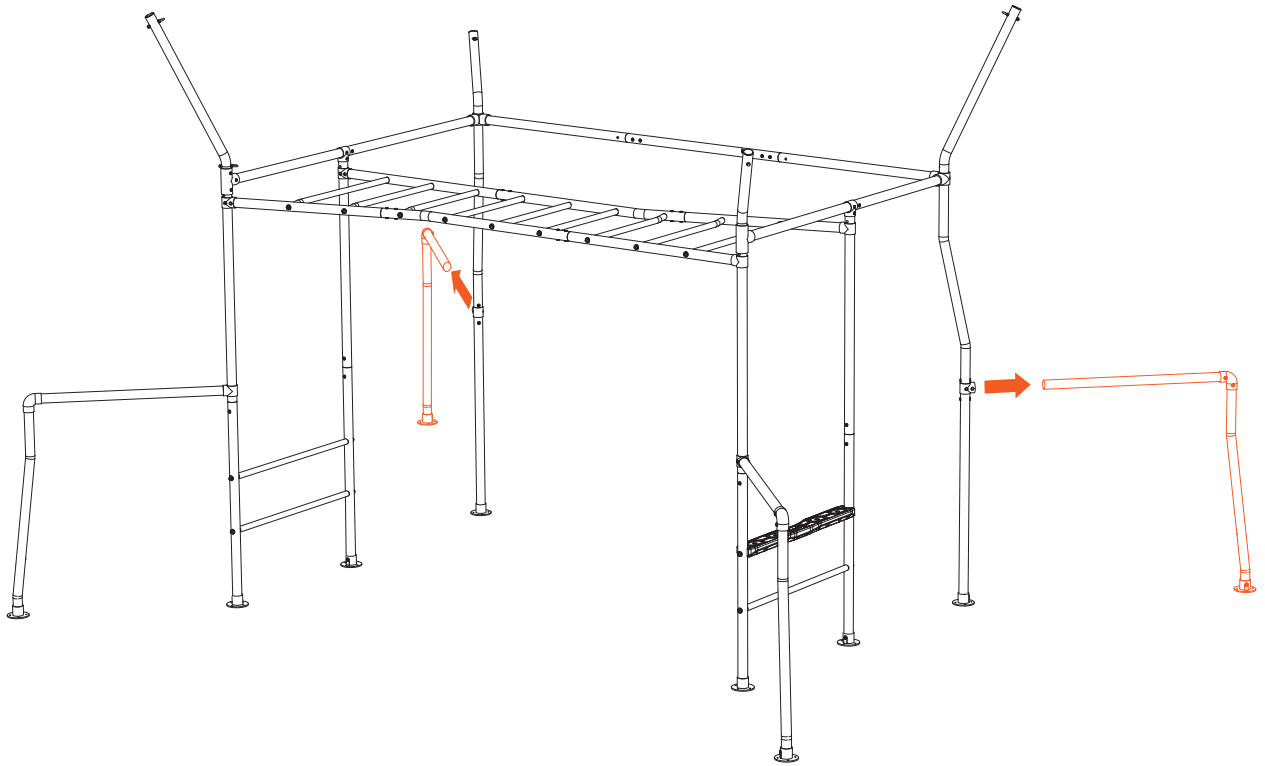

5



 **NOTE:** If you have Flying Fox accessory, ensure it is securely fastened before proceeding. 



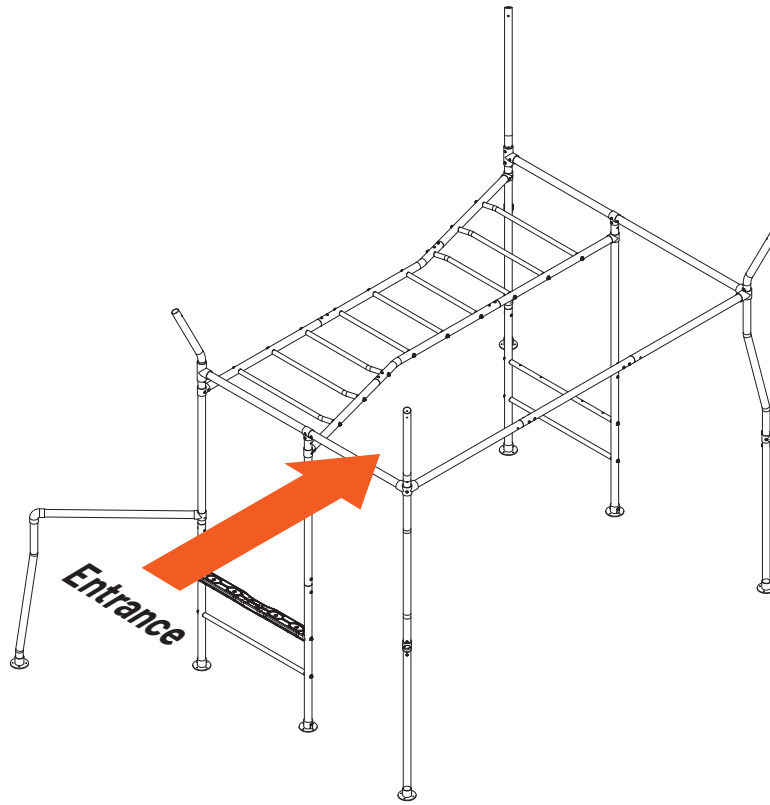

6

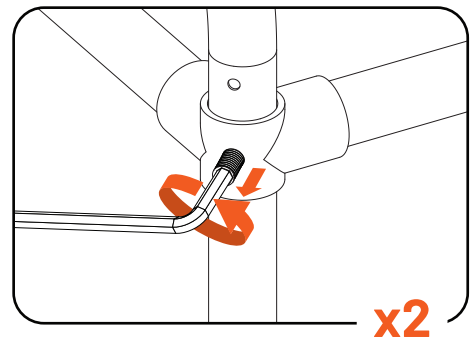
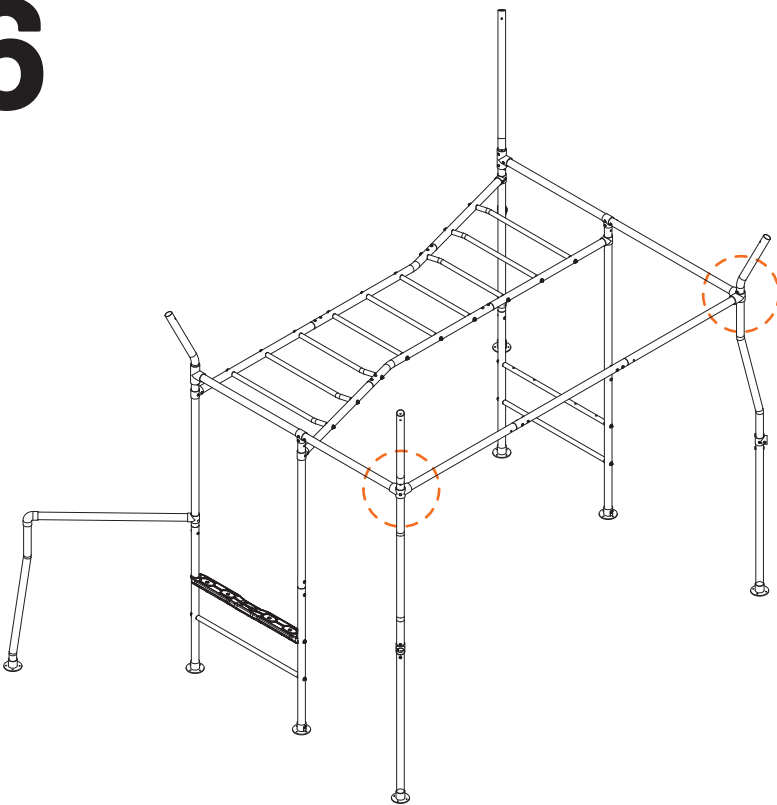

7

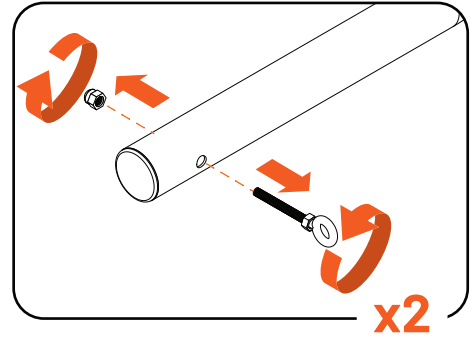
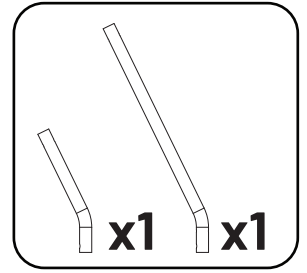
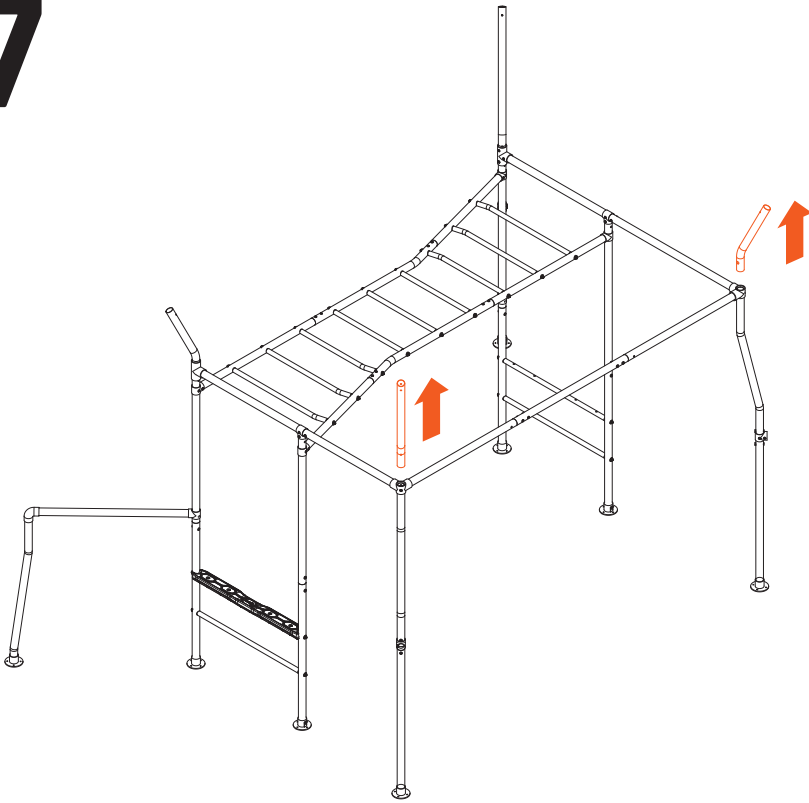

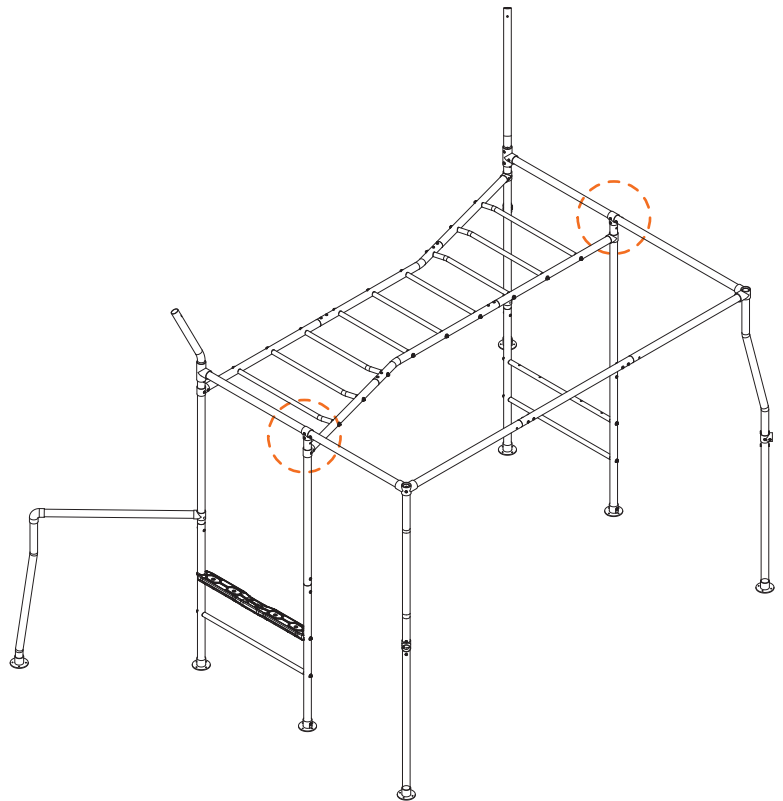
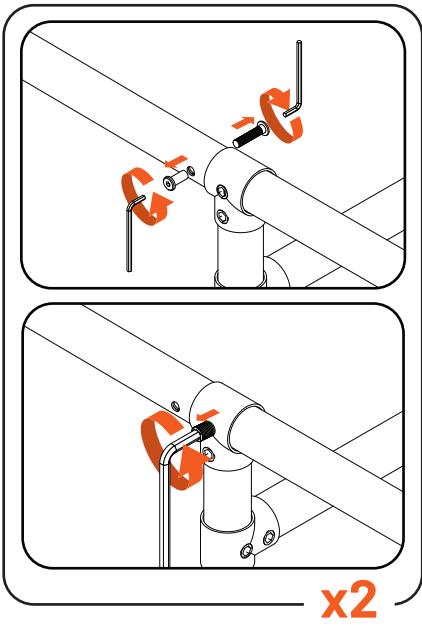

8

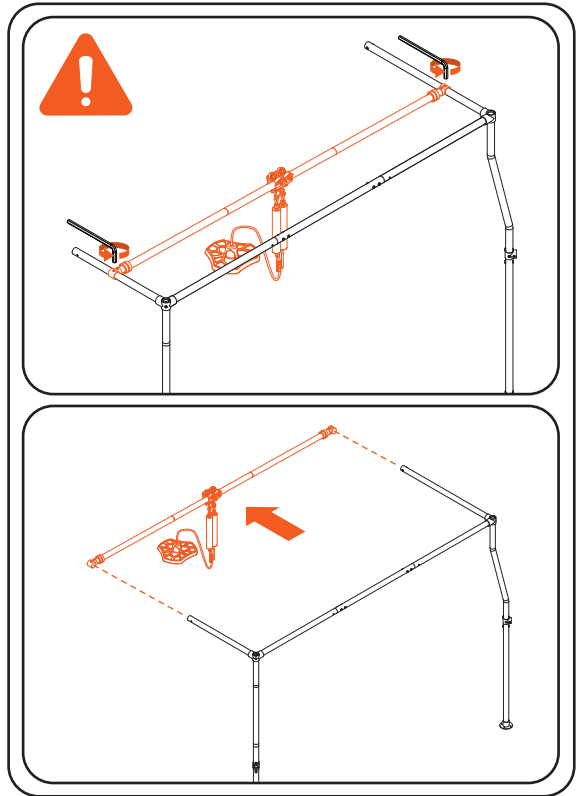
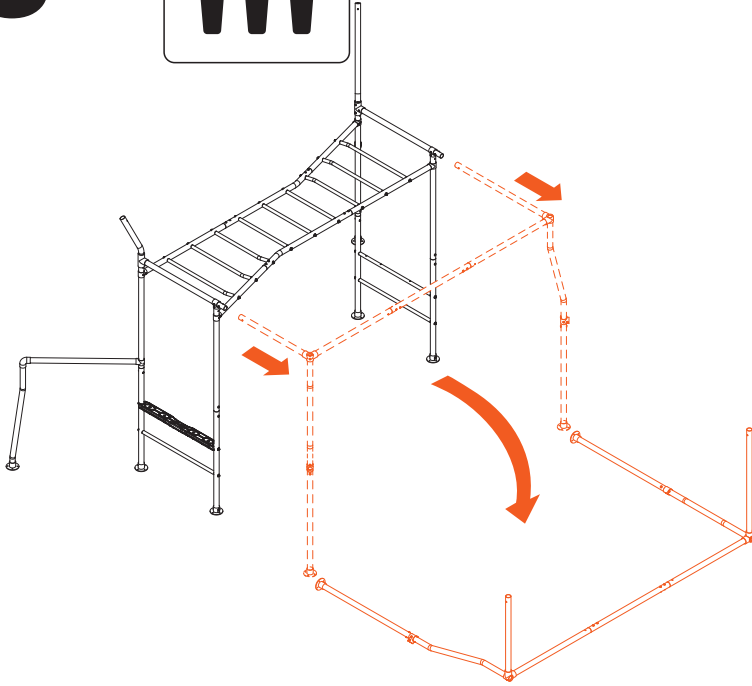
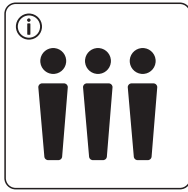

9



 **NOTE:** If you have Flying Fox installed, Ensure to remove it before proceeding to the next step. 

10

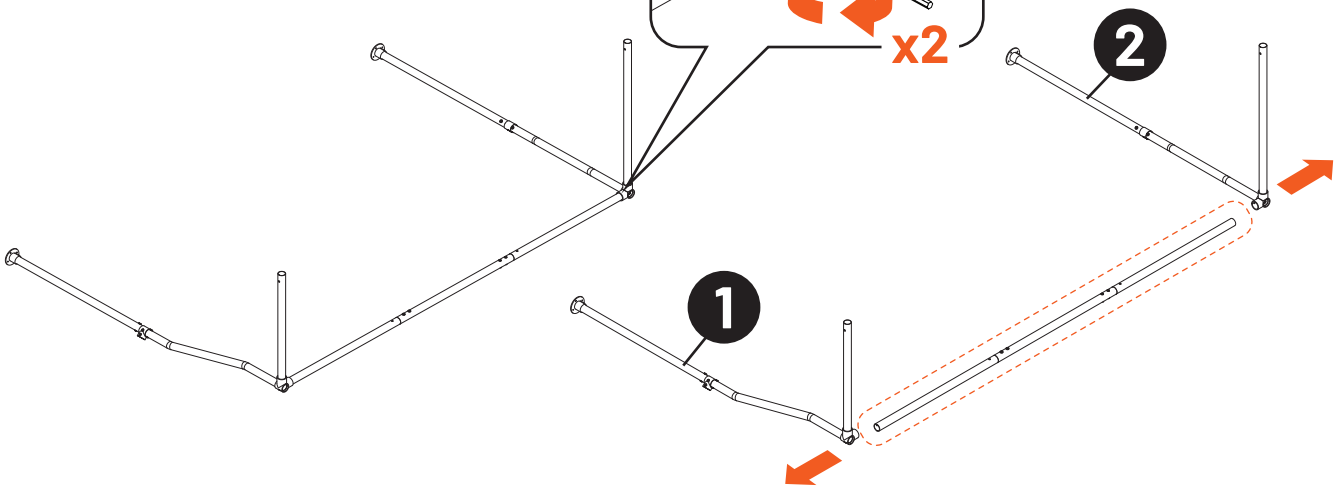
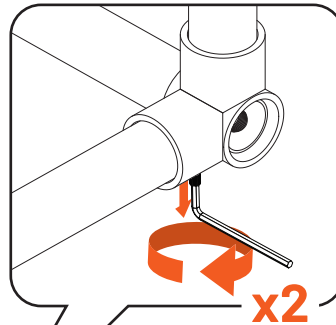

11

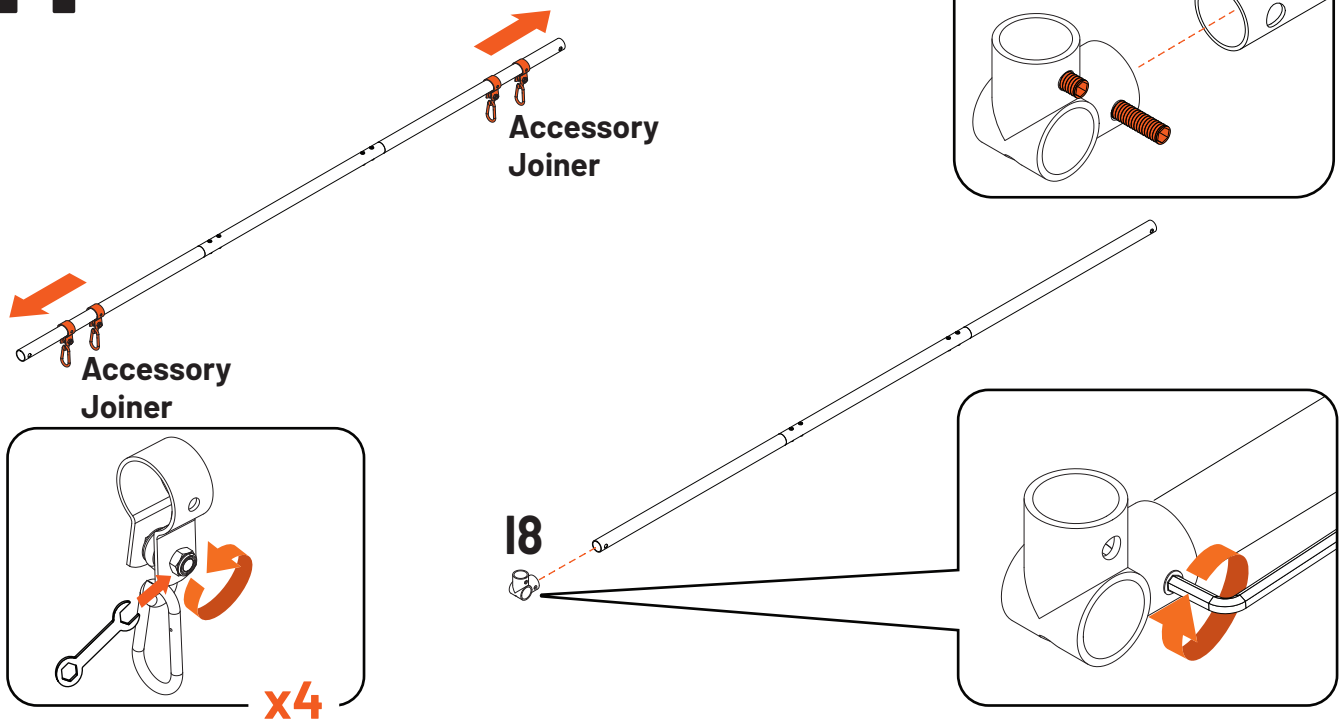

NOTE: Ensure to remove all Accessory Joiners before proceeding to the next step.



12

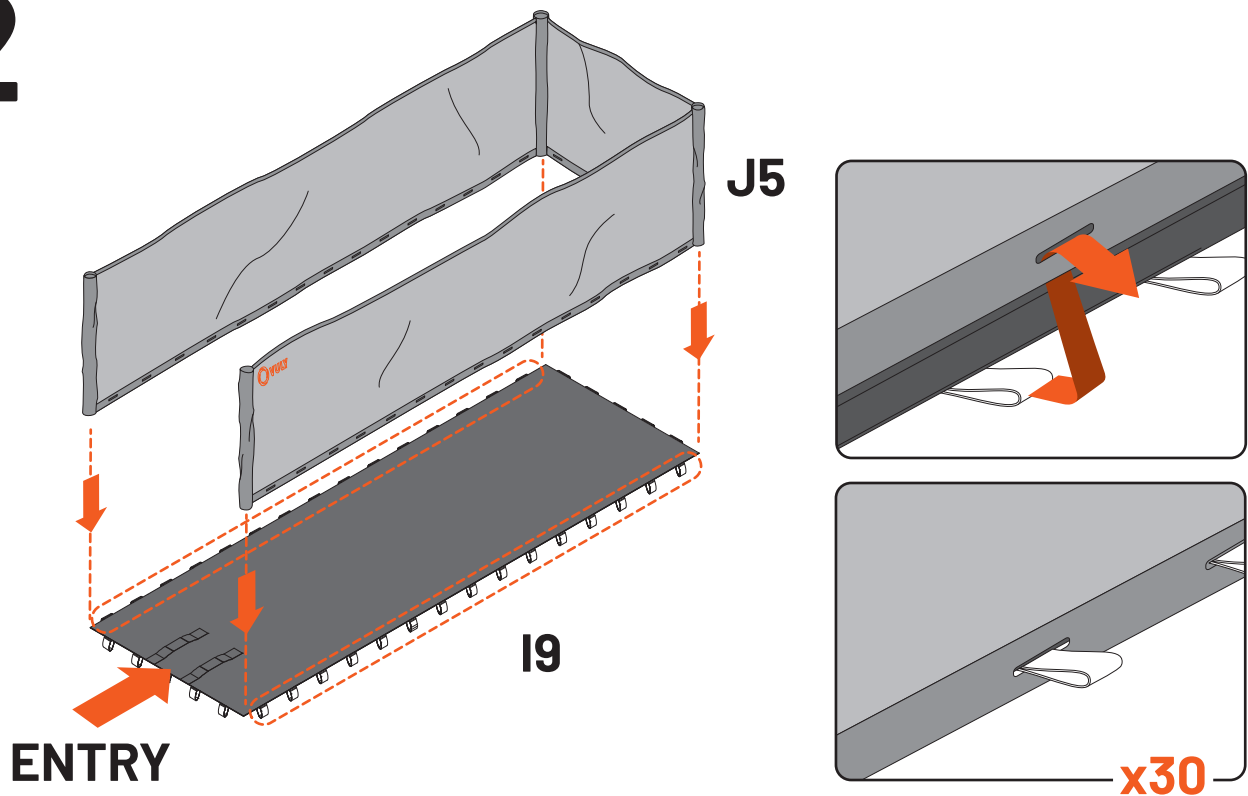

NOTE: Pay attention to Overpass Entry. Ensure Pull Handles on Overpass Platform faces up.



13

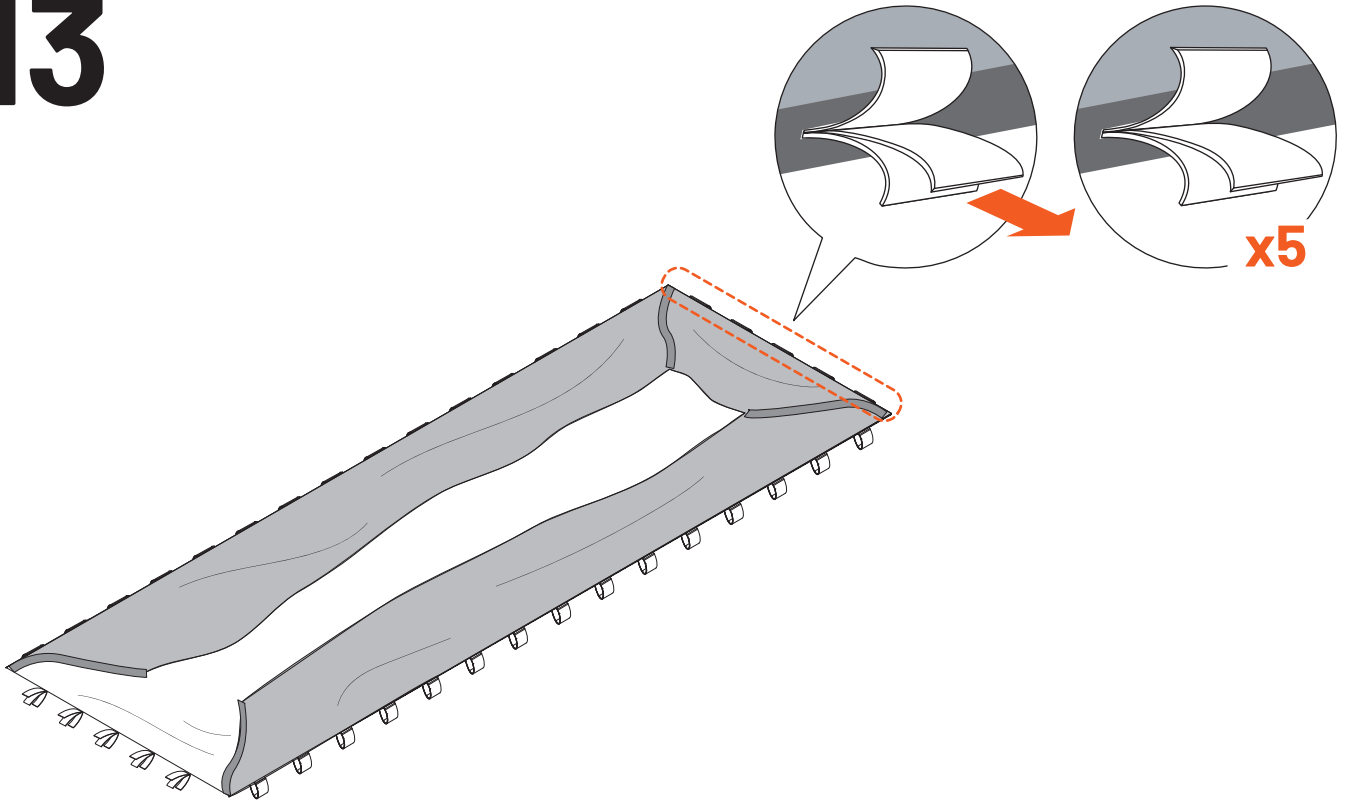

14

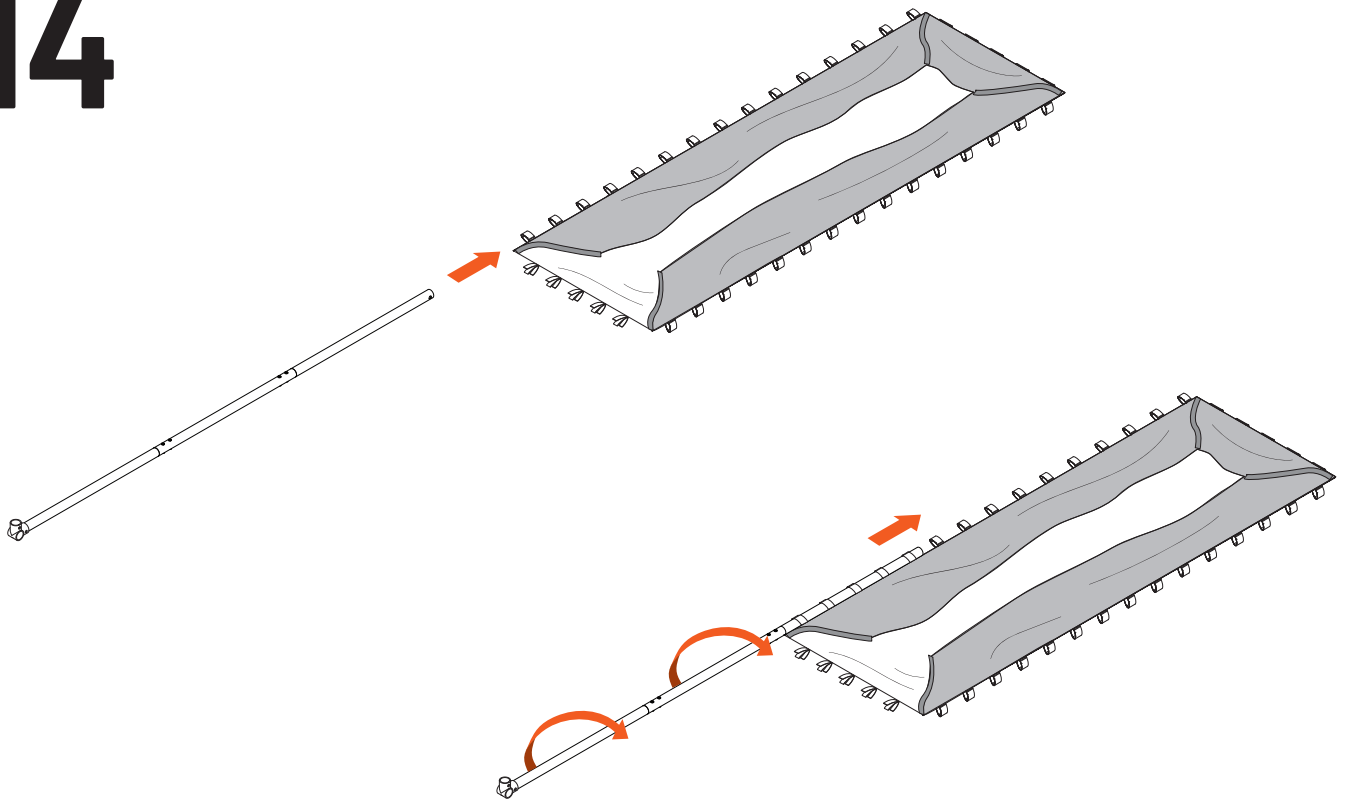



NOTE: If having difficulties looping the tube through, try twisting it while feeding.

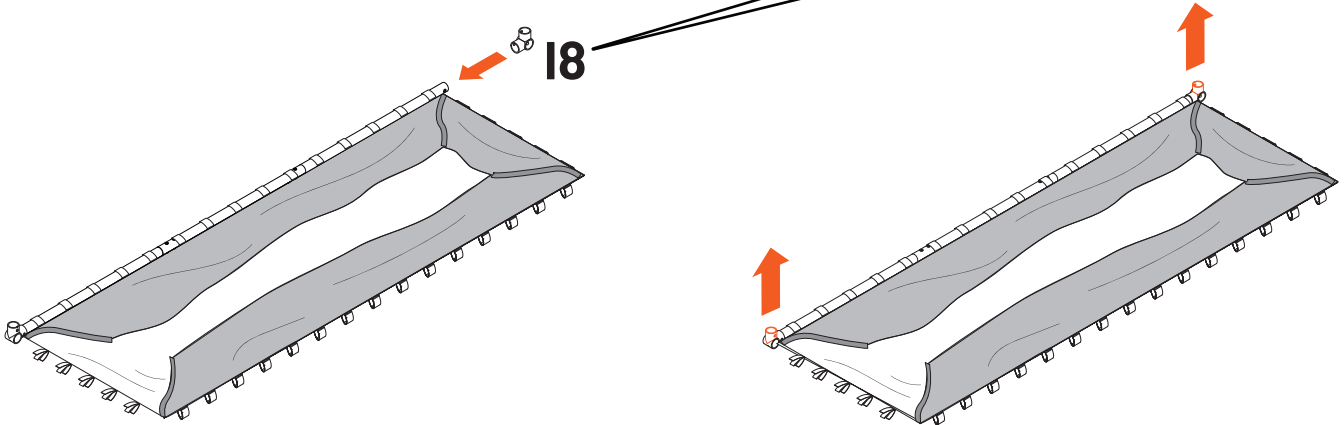
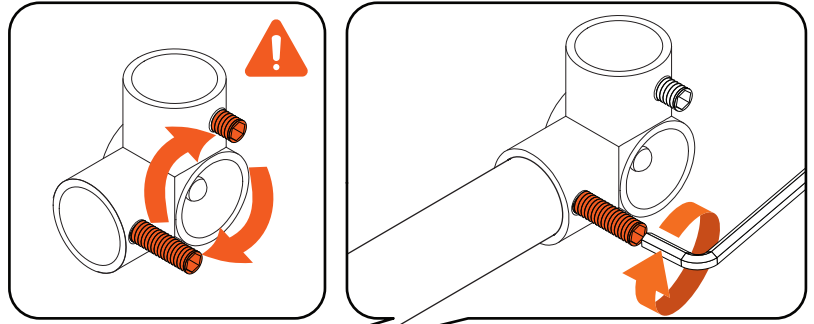

15



 **NOTE:** Ensure the Joiners are positioned as shown. 

16

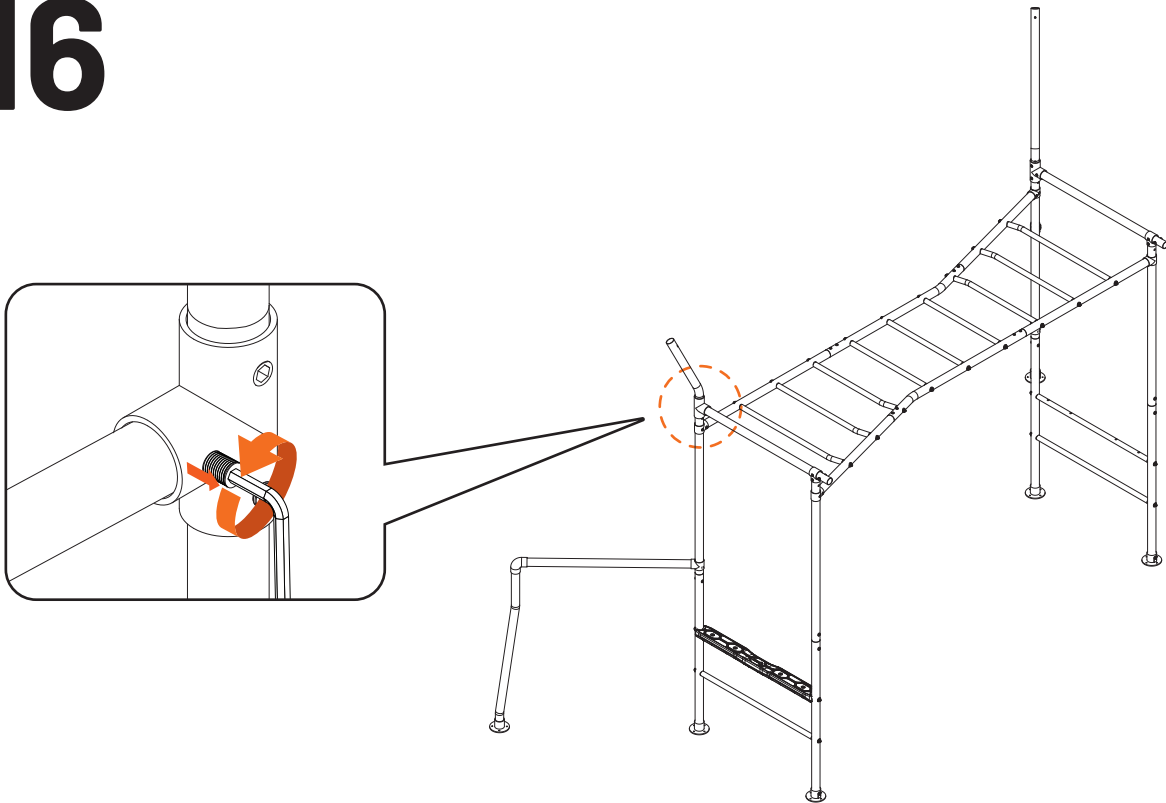

17

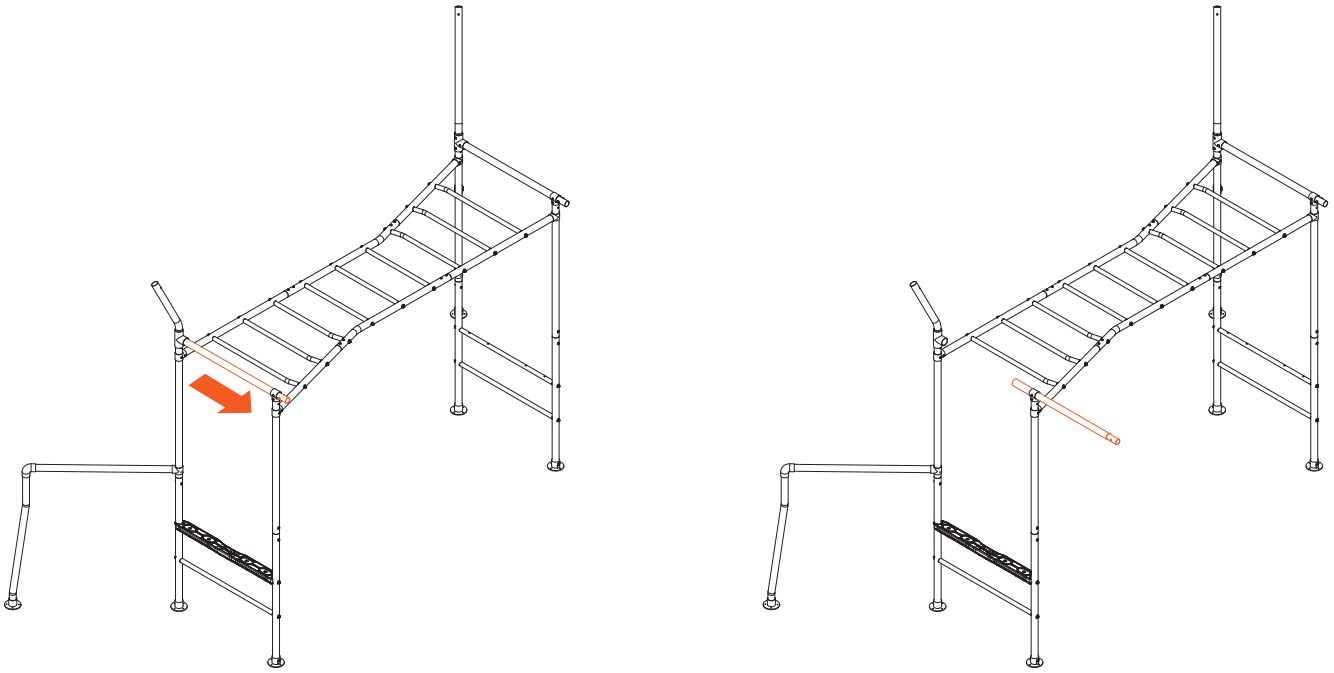

18

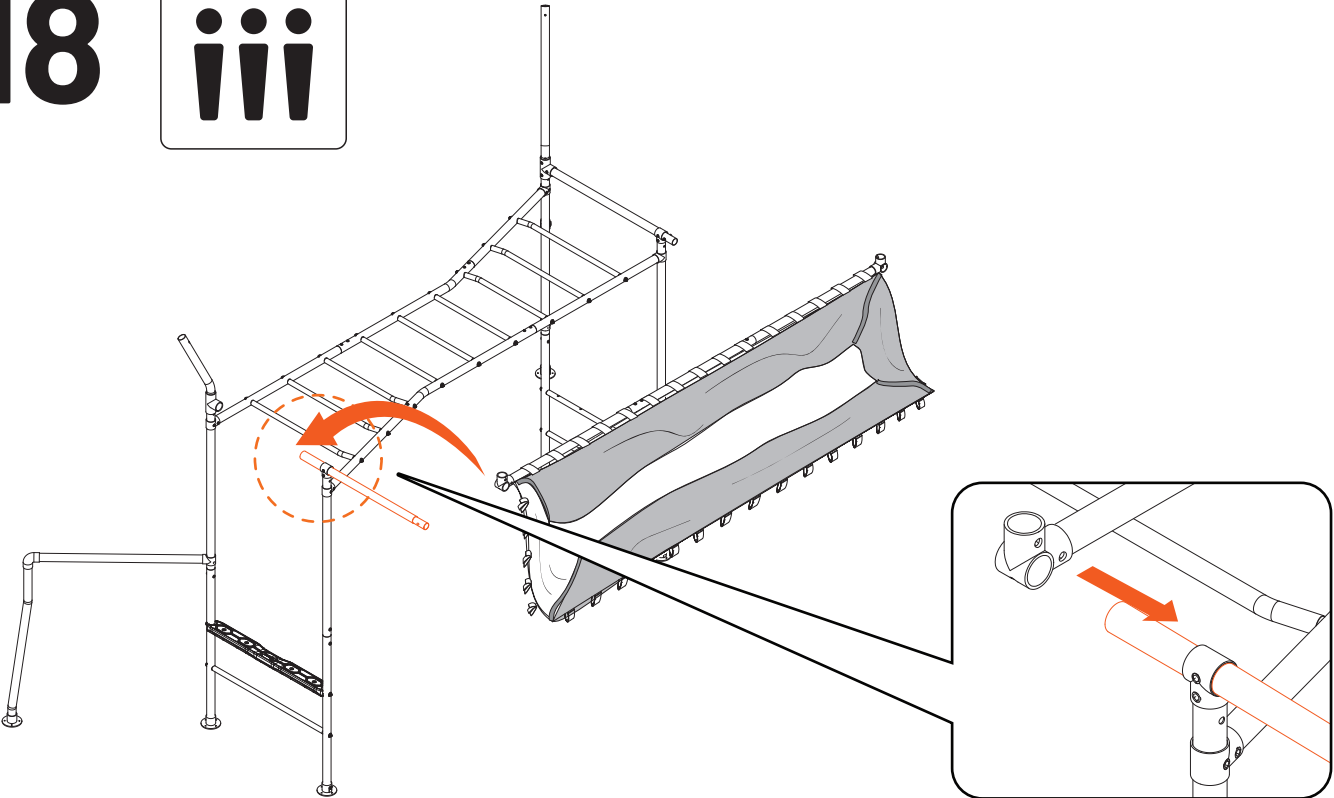
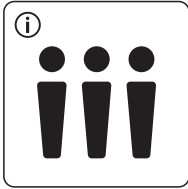

WARNING! Pay close attention to the Entry of Overpass. The Overpass can only be installed as shown in diagram, not the opposite. **!**



19

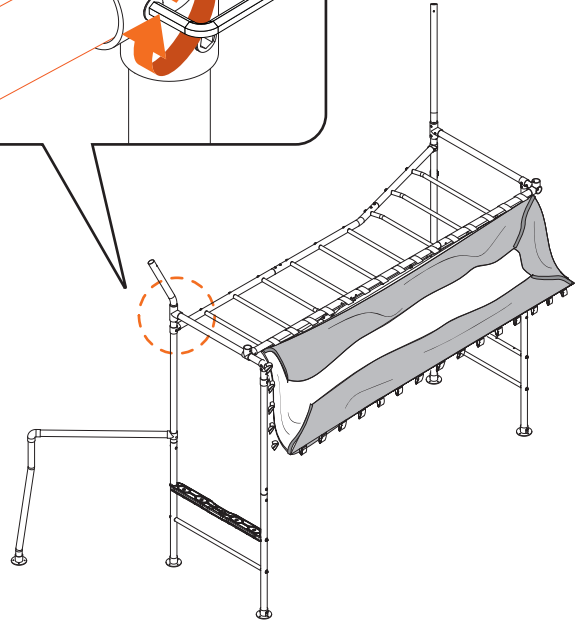
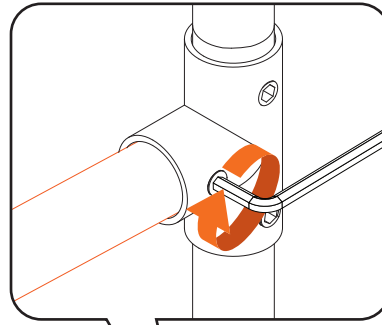
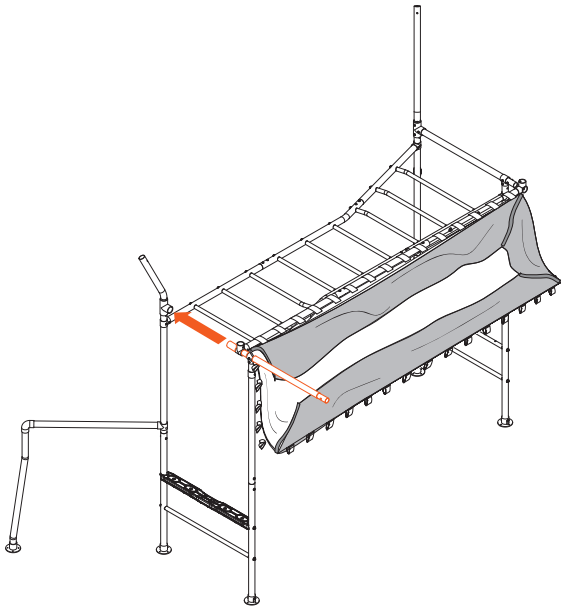
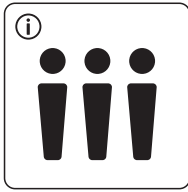

20

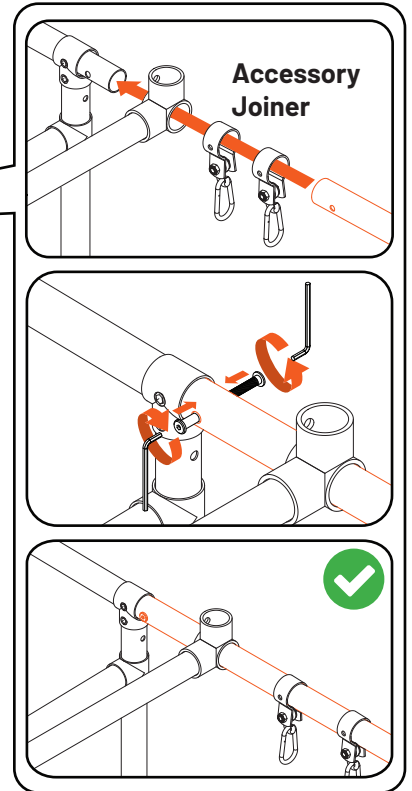
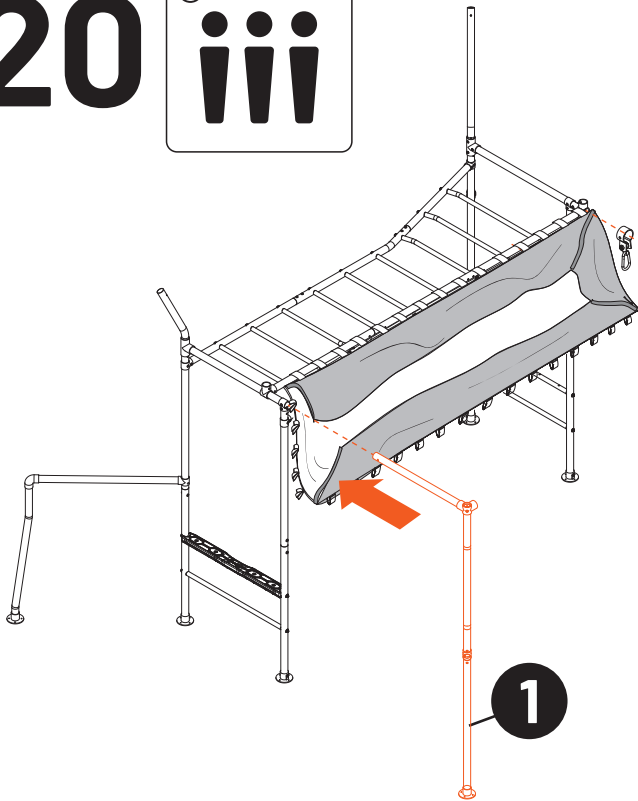
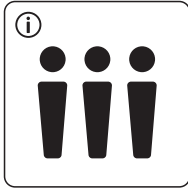

21

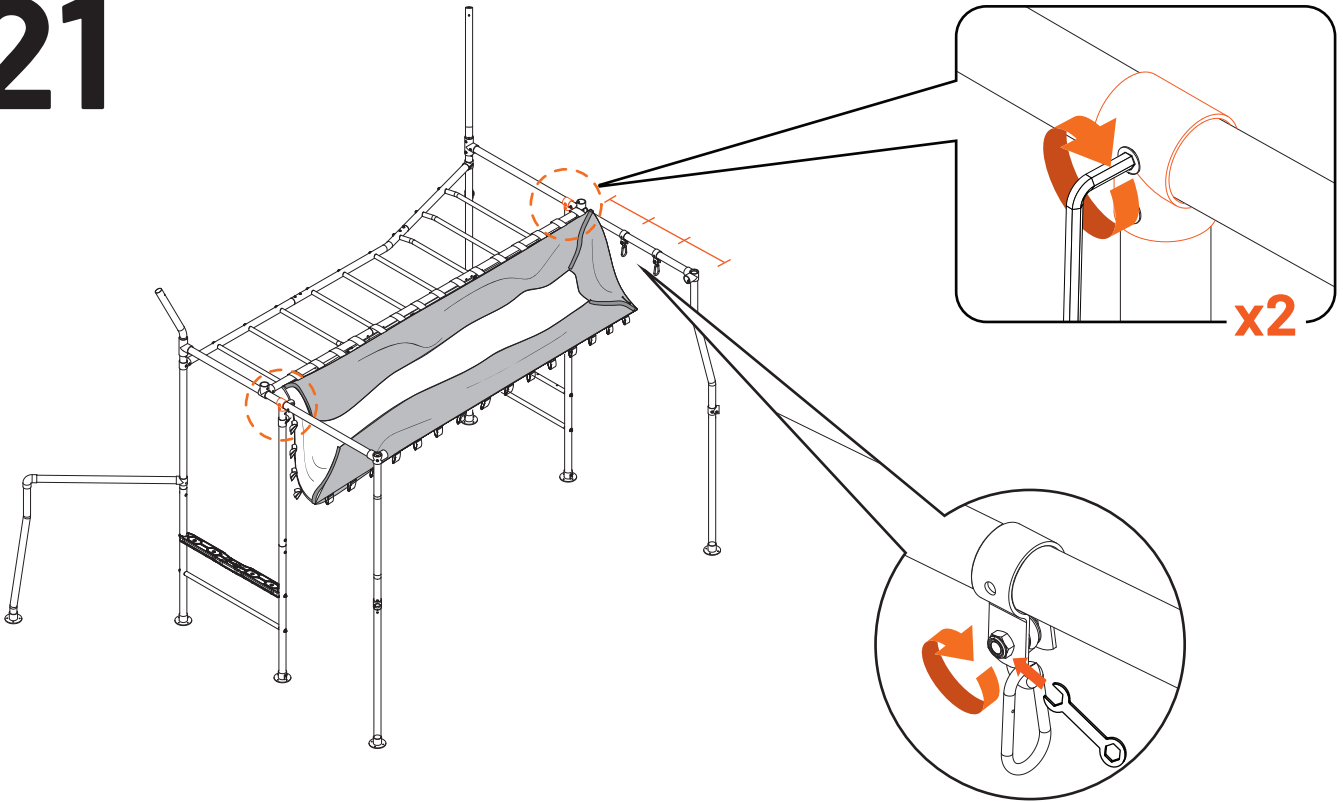

! NOTE: Ensure Accessory Joiners are roughly equal distance apart before tightening. **!**

22

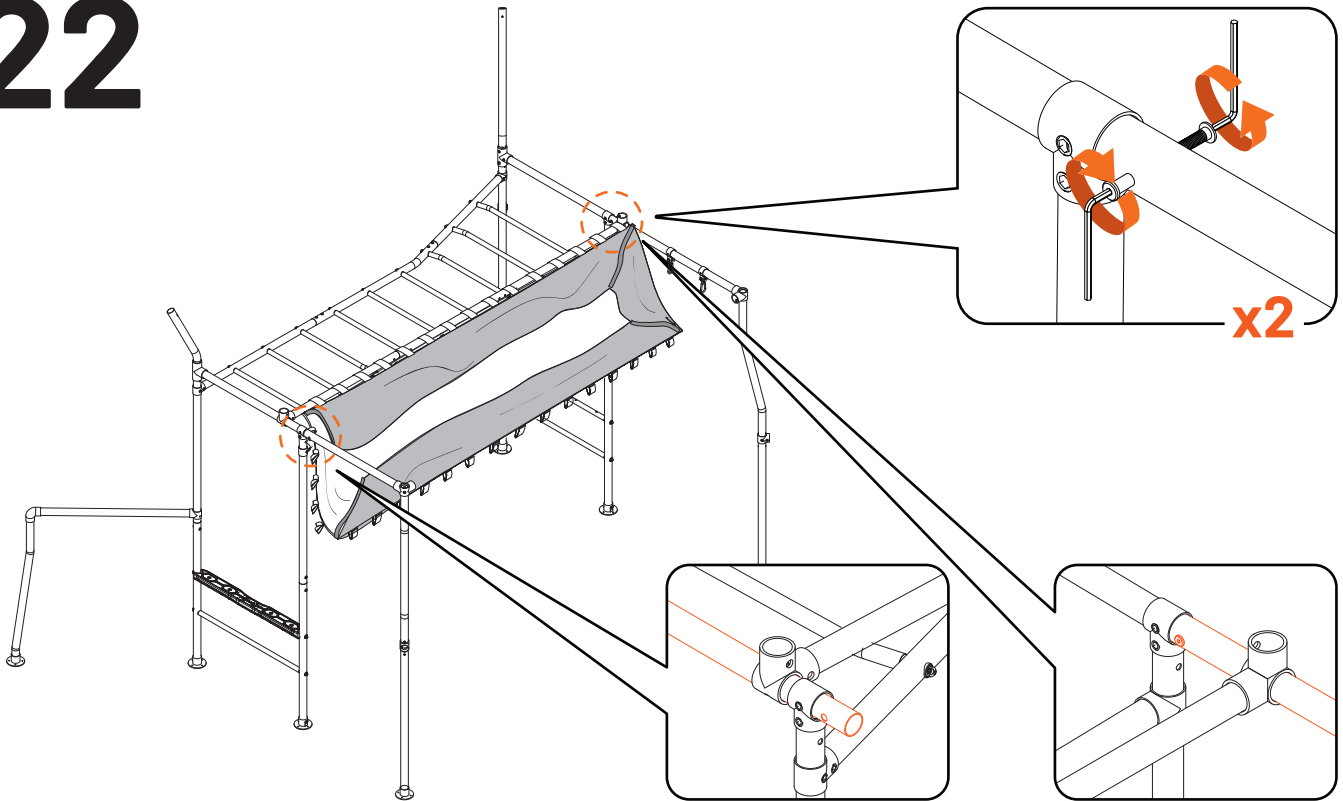

23

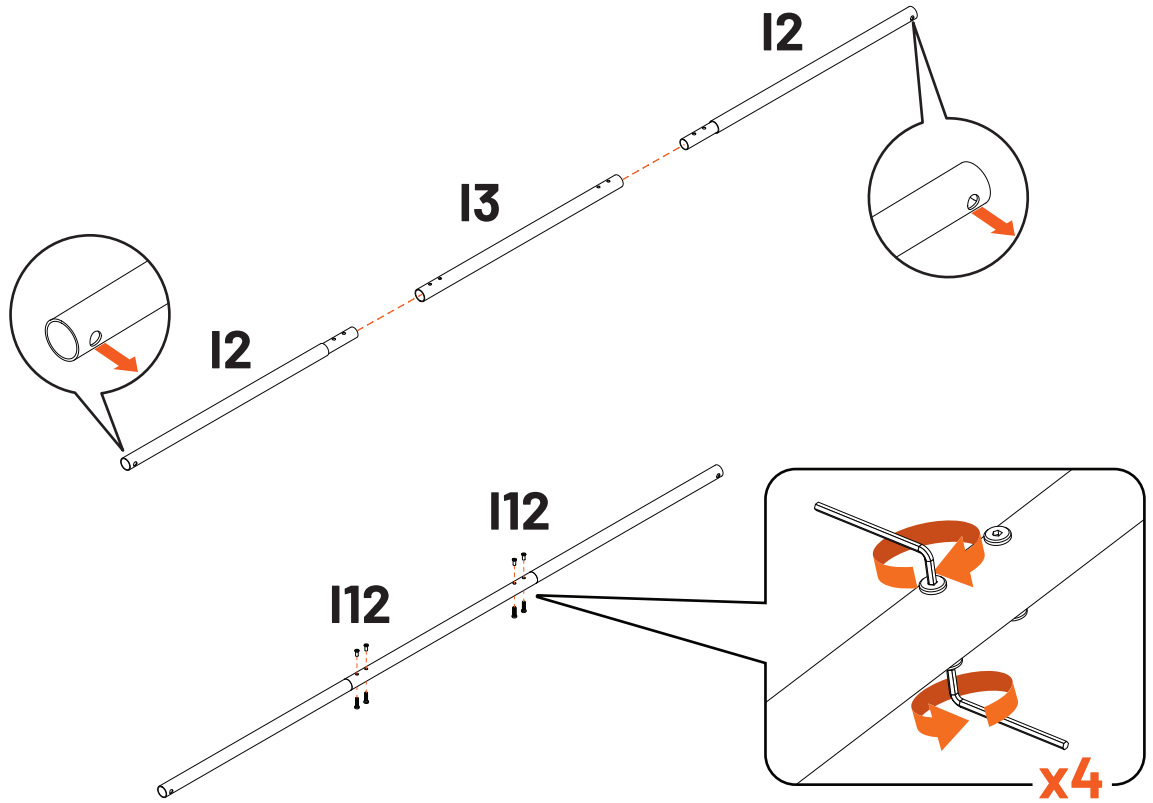

NOTE: Holes on I2 Tubes faces the same direction.



24

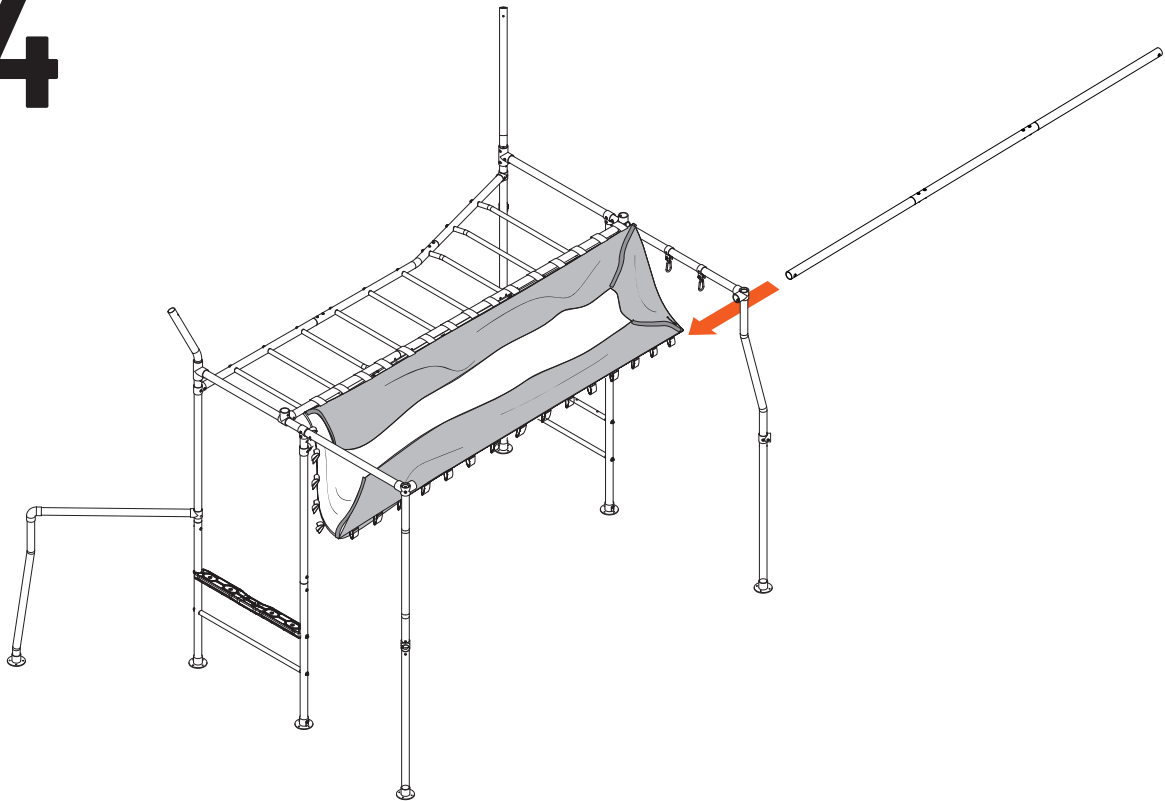

25

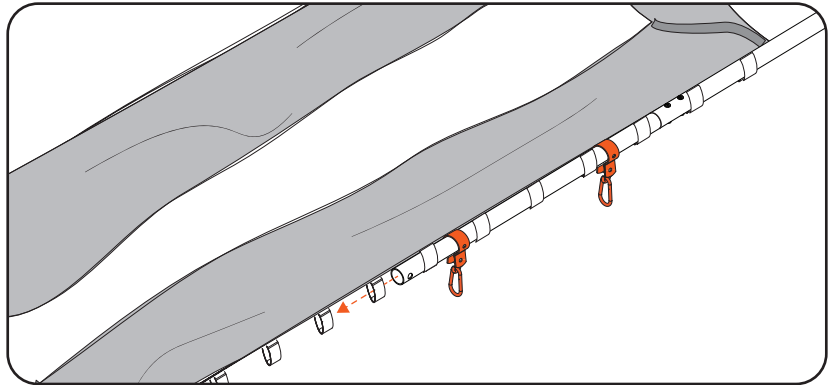
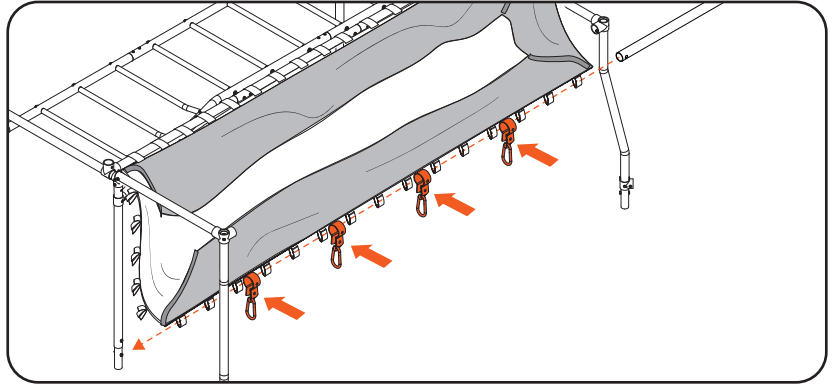
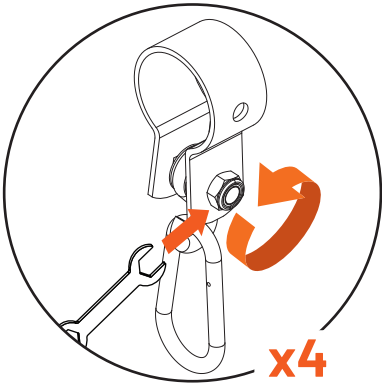
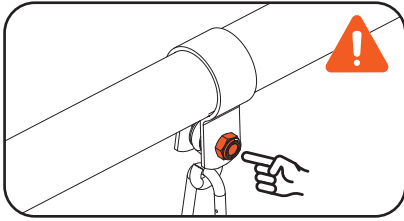

NOTE: Ensure Safety Net is secured to Overpass before looping the tube through, and Nylon Nut on Accessory Joiners are oriented outside of the frame. 

26

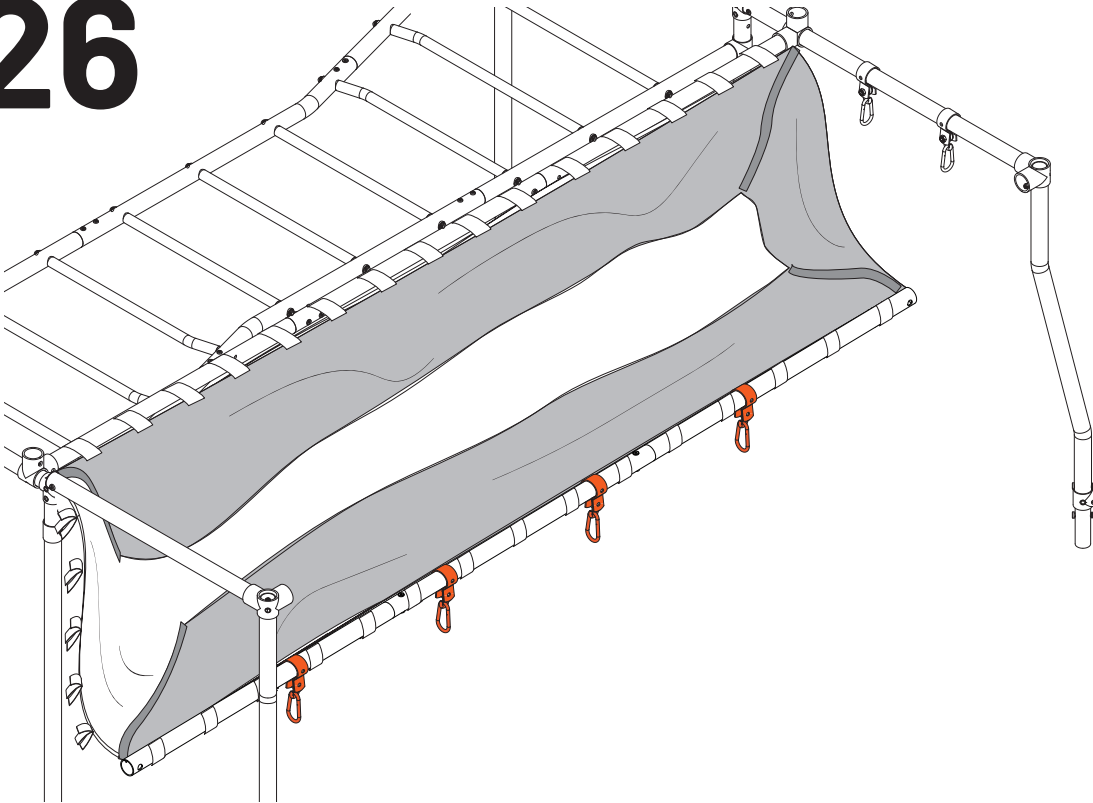

NOTE: Only finger tighten the Accessory Joiners at this step. 



27

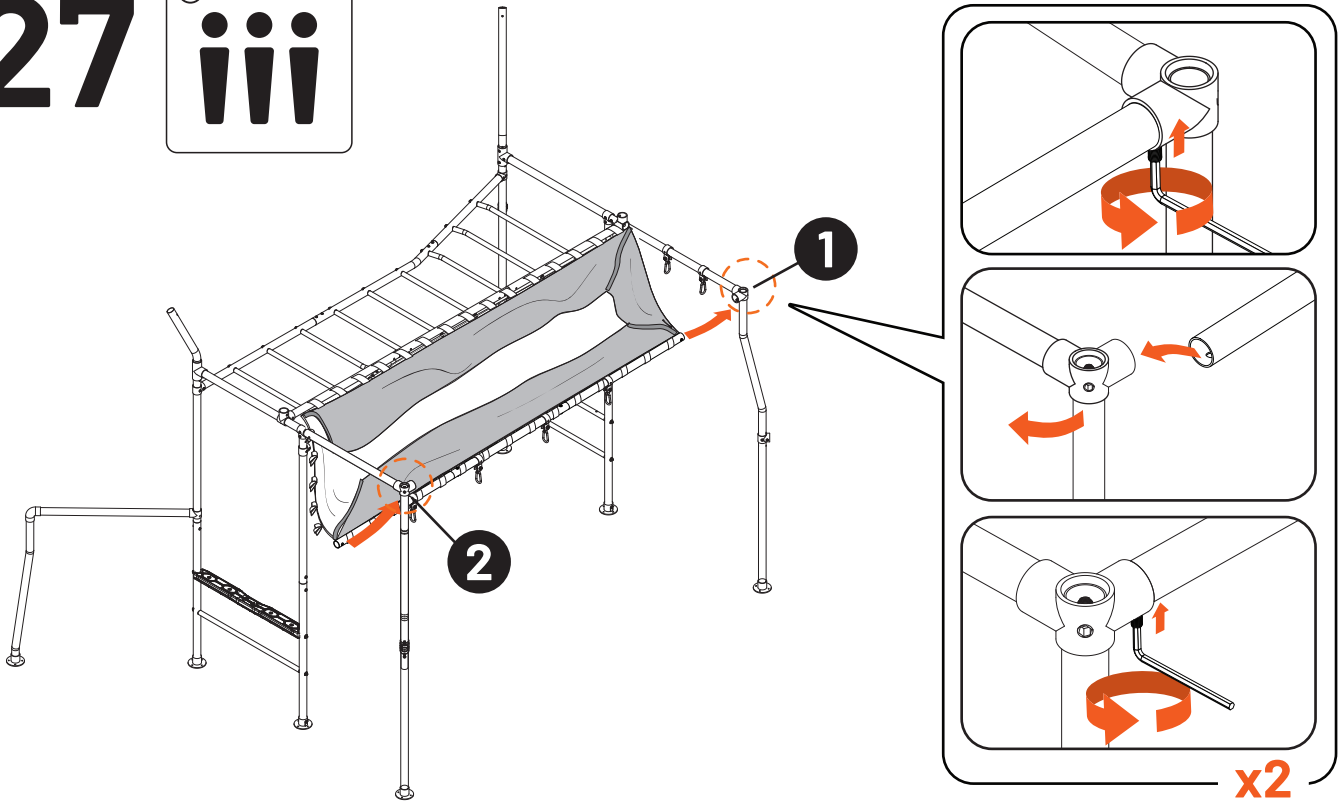
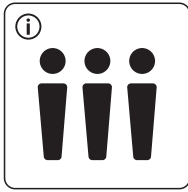

NOTE: If having difficulties, start with the opposite corner.



28

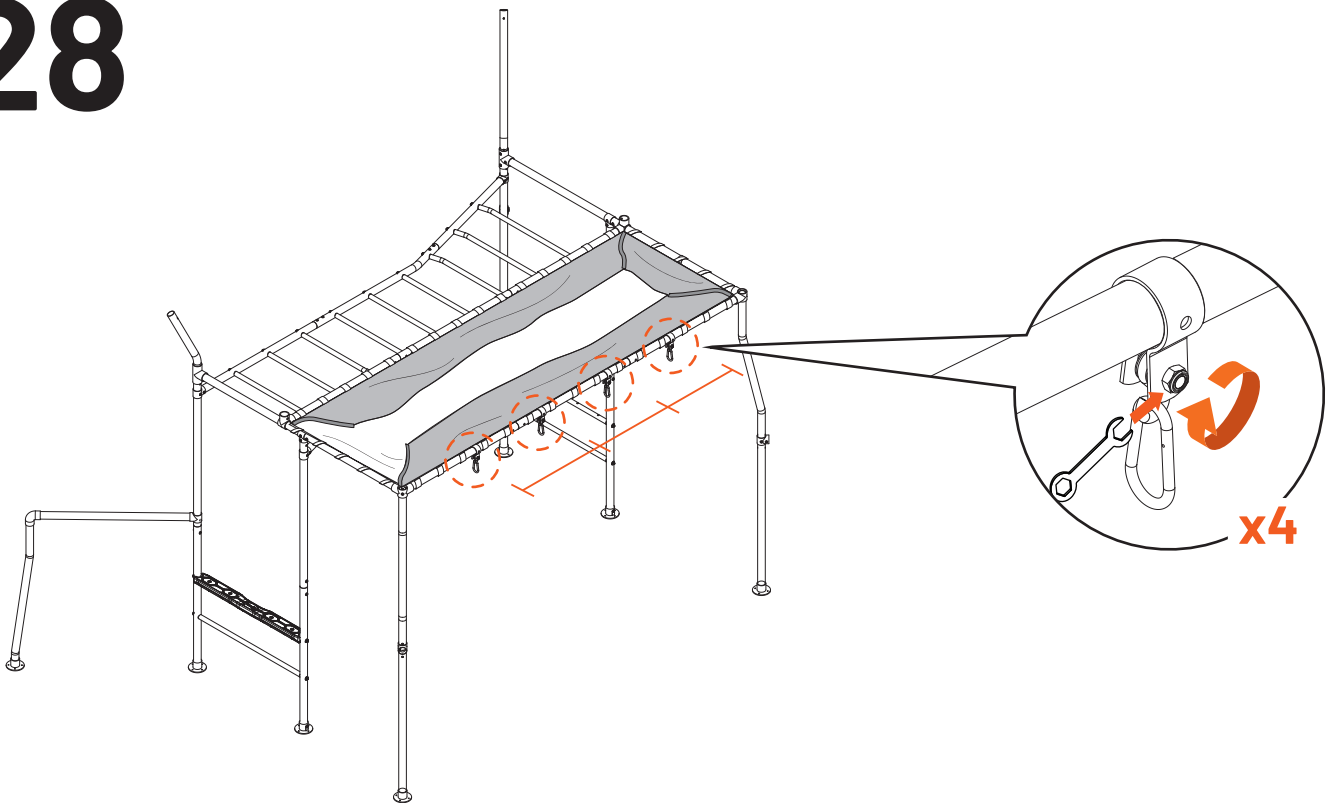

NOTE: Ensure Accessory Joiners are roughly equal distance apart before tightening.



29

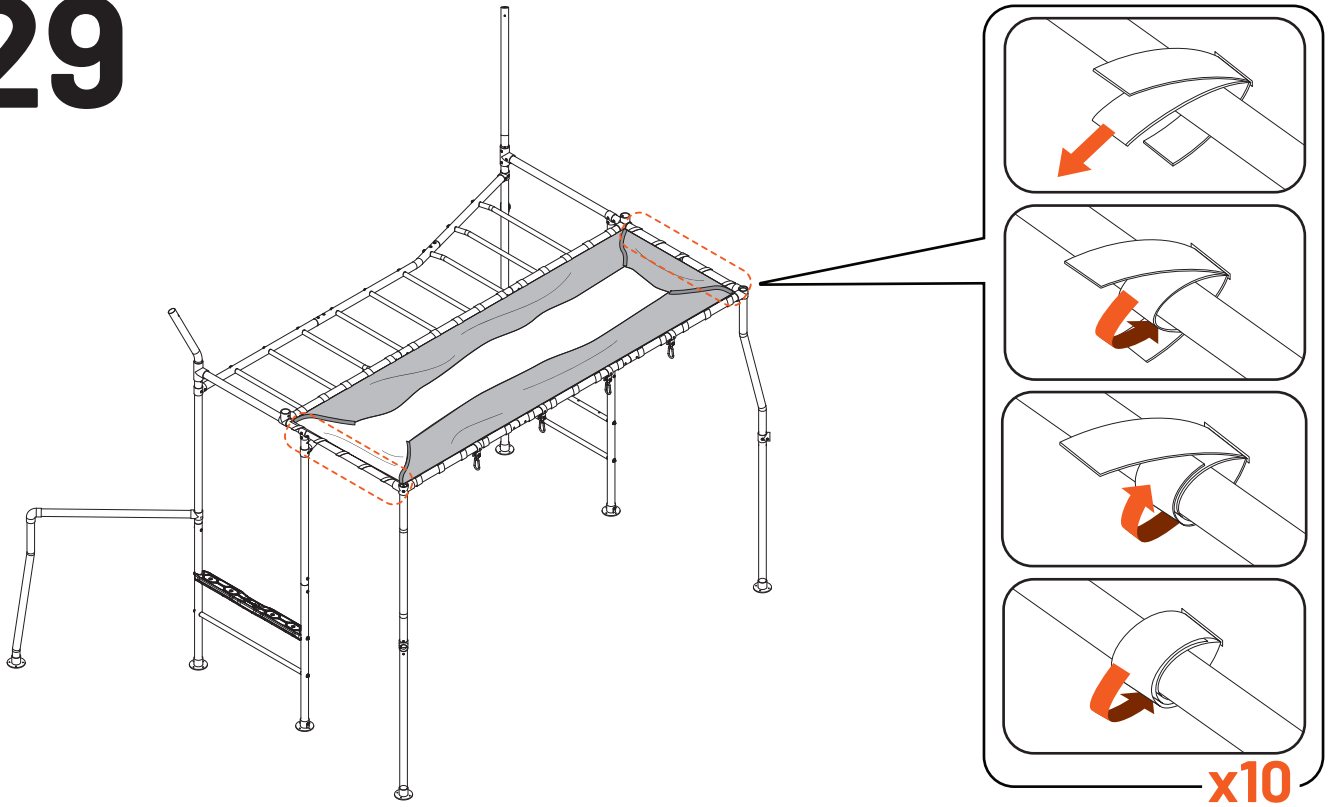

30

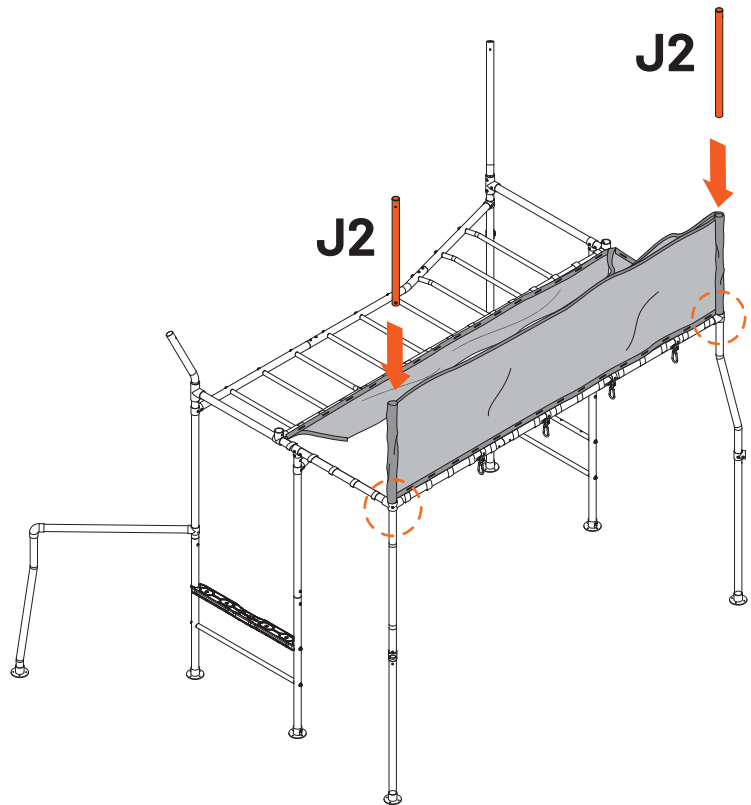
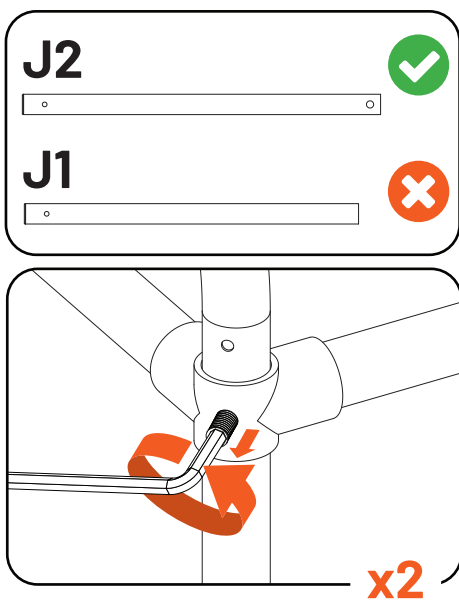

NOTE: Only undo grub screw enough to insert tube J2.



31

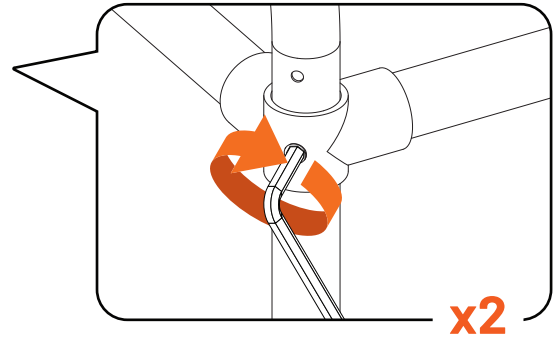
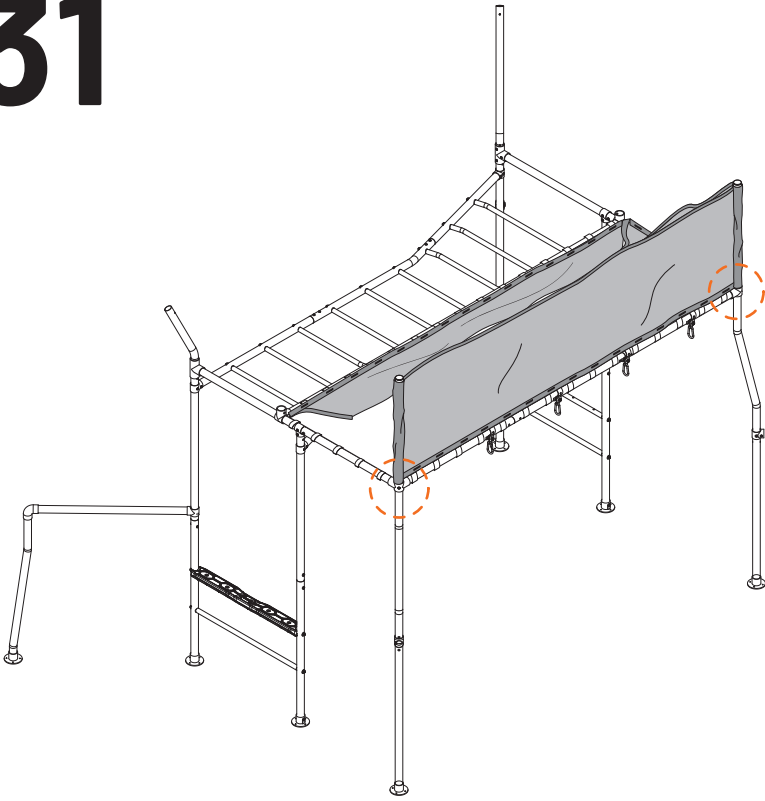

32

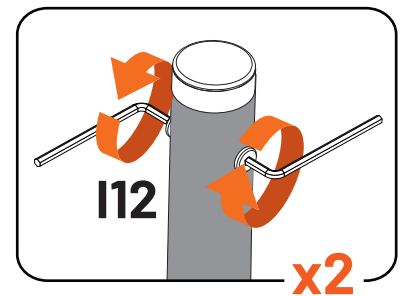
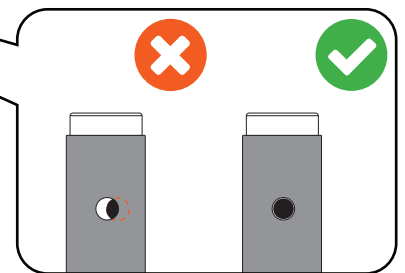
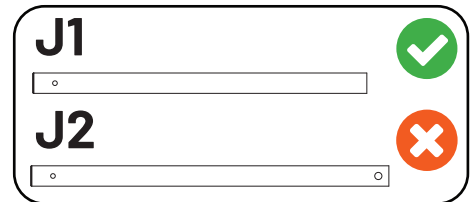
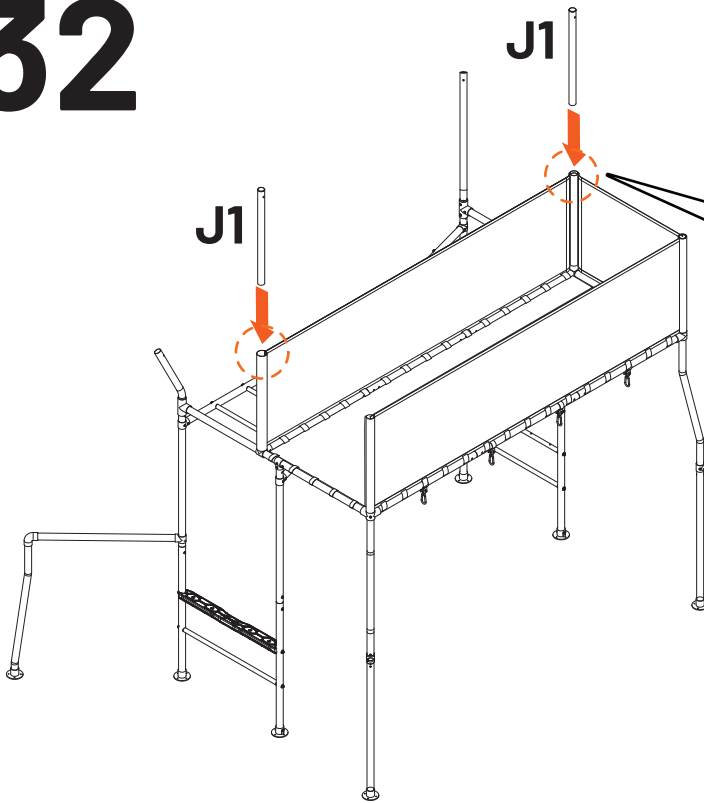

33

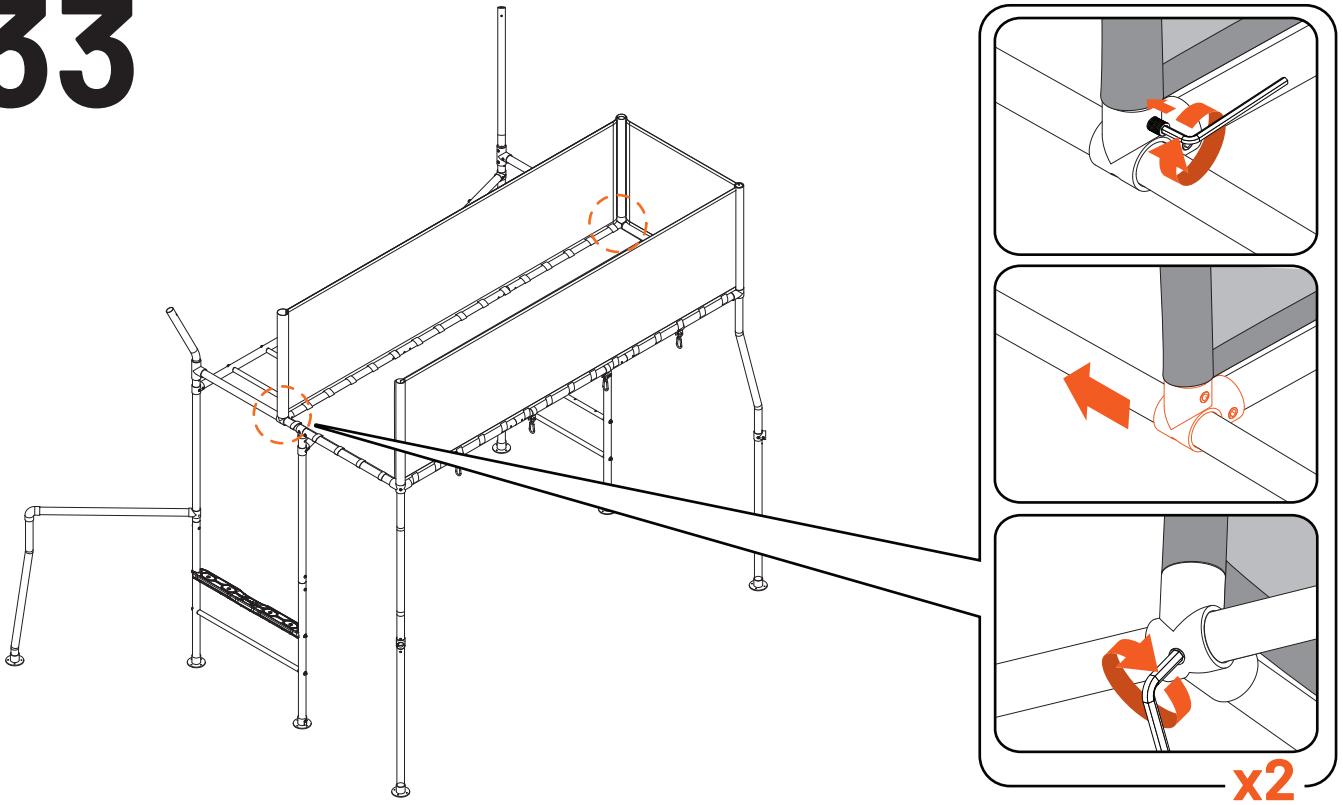

NOTE: Slide Joiners in direction of arrow to tension Hideout assembly, tighten Grub Screw to lock in place.



34

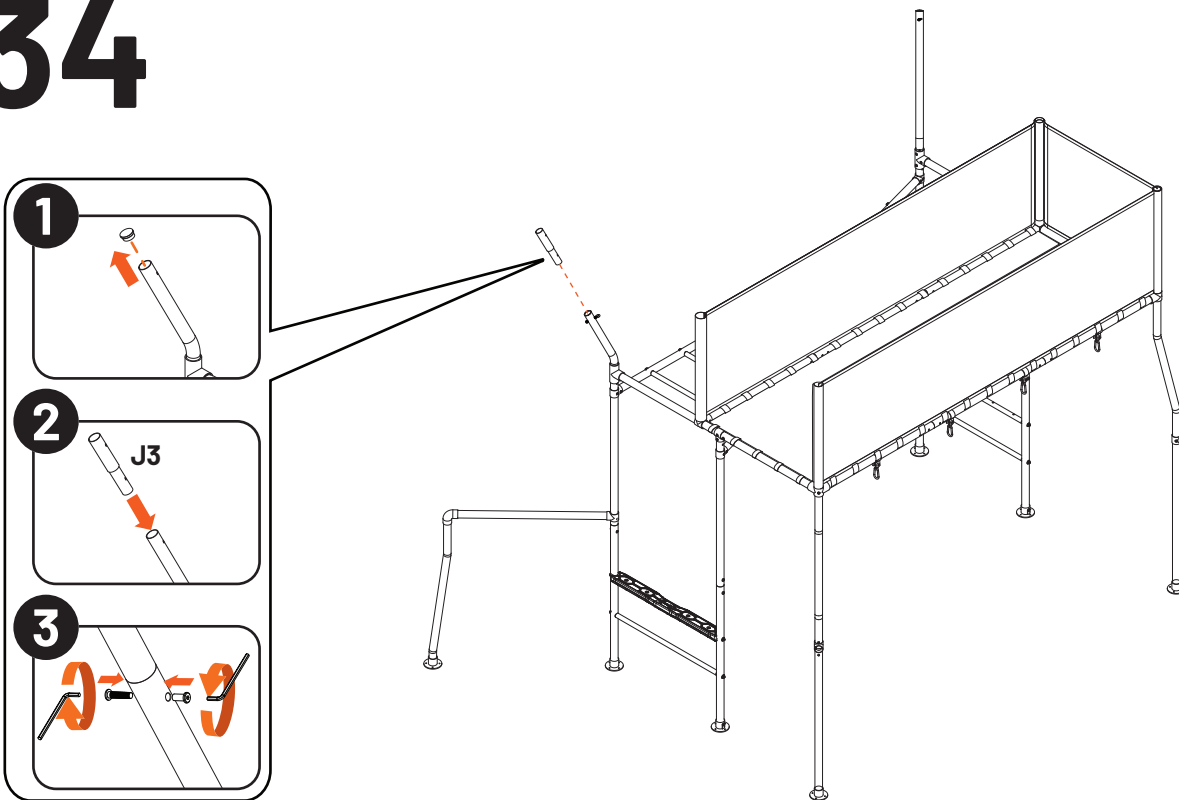

35

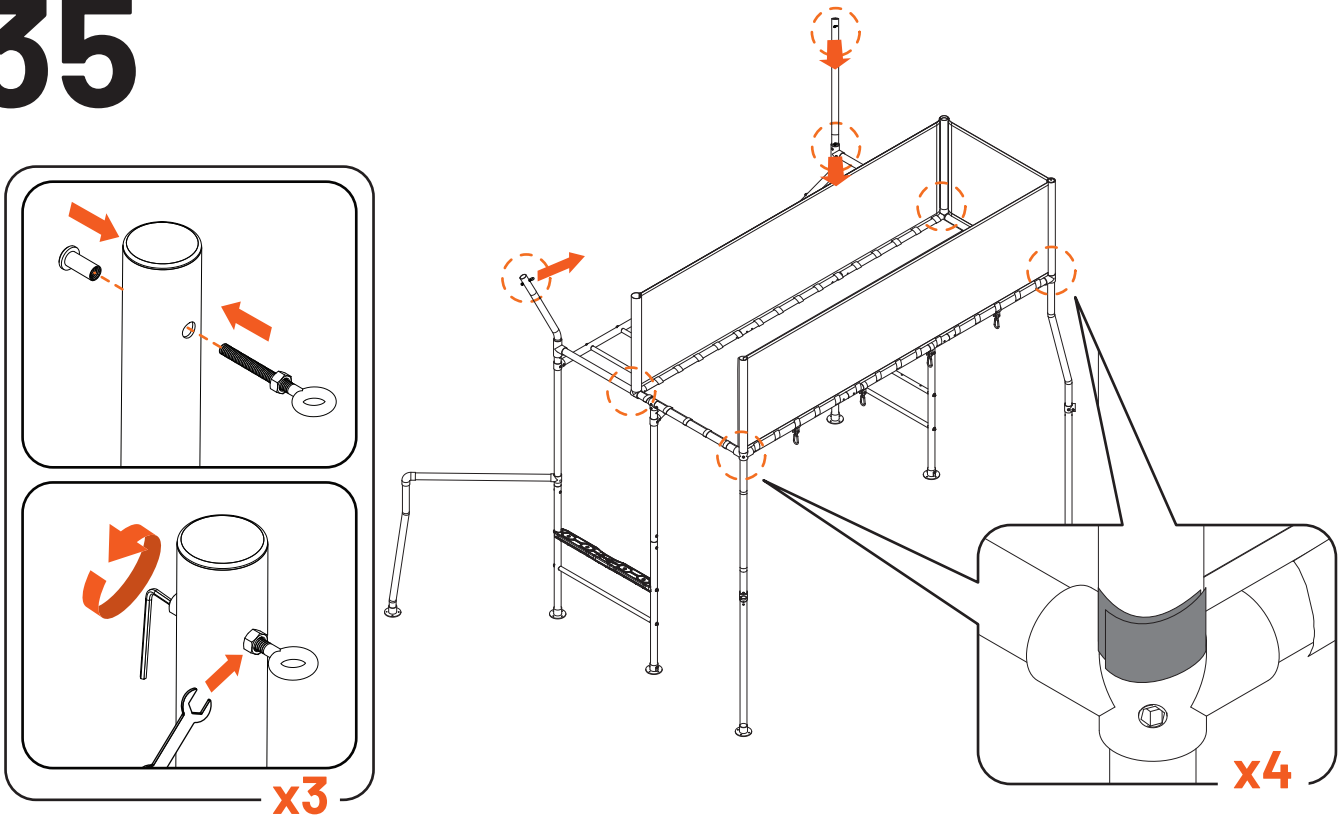

NOTE: Pay attention to direction of Eye Bolts.



36

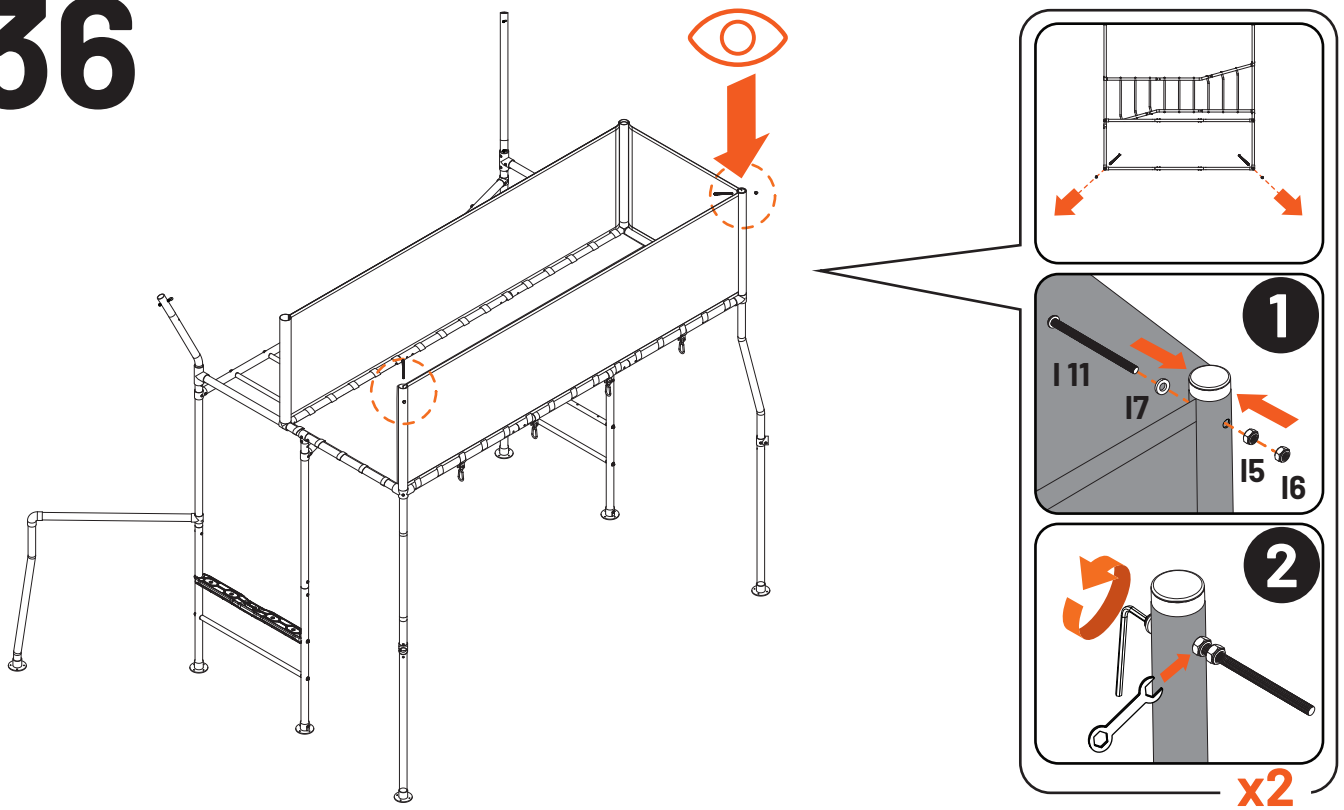

37

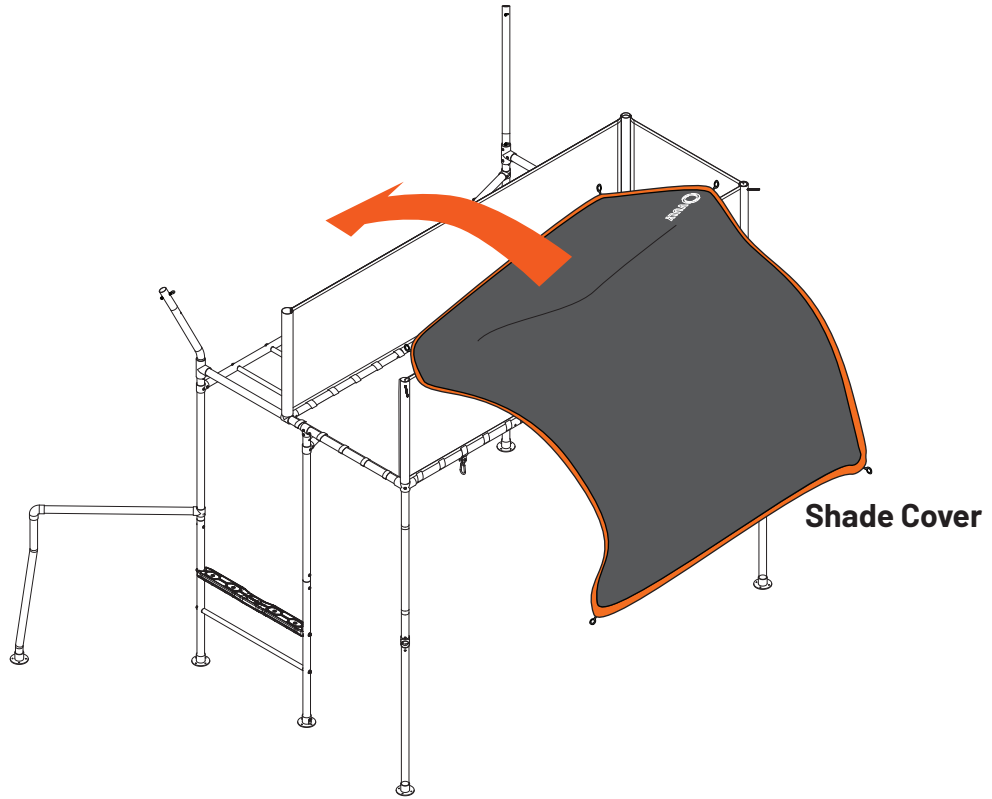

38

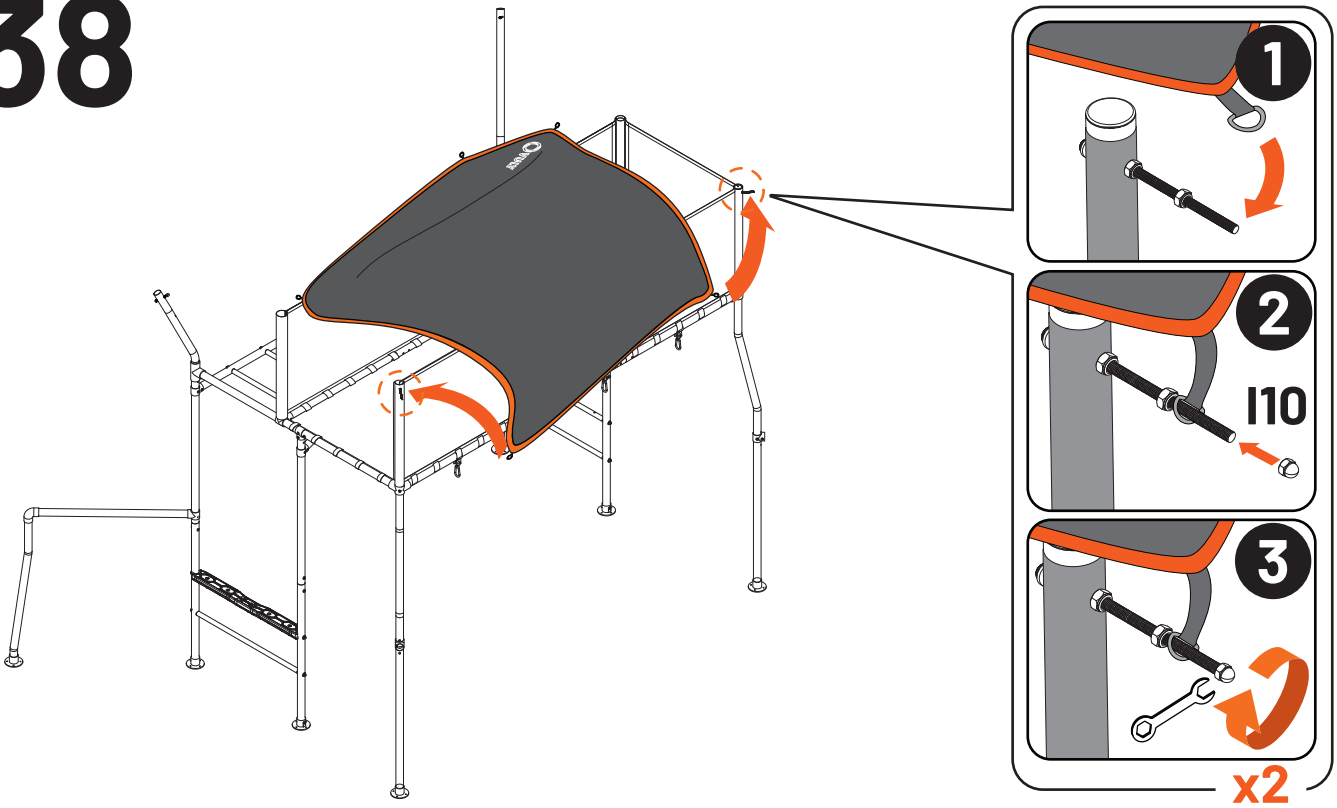

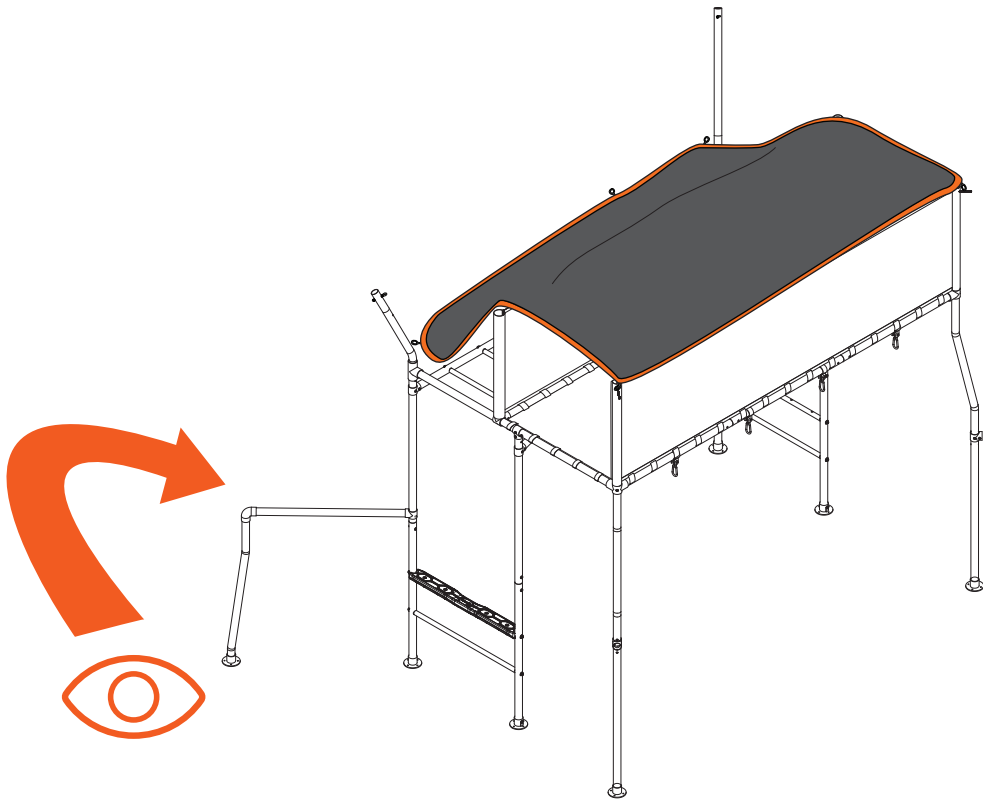

39

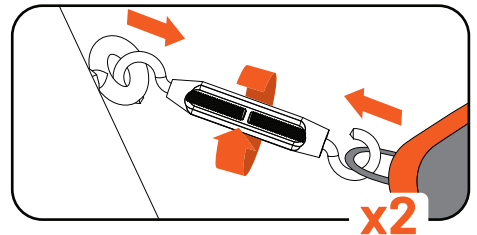
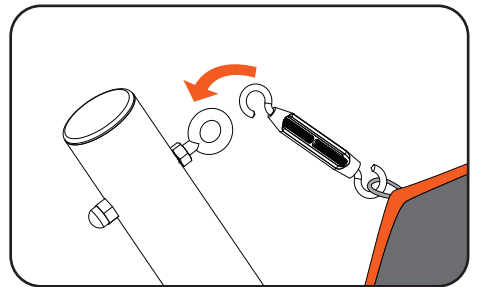
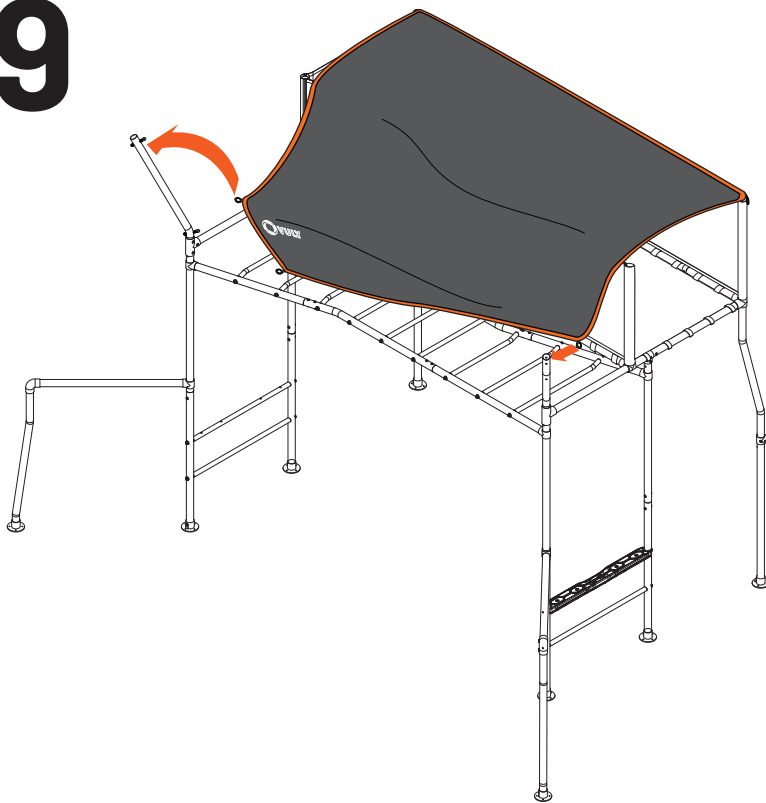

40

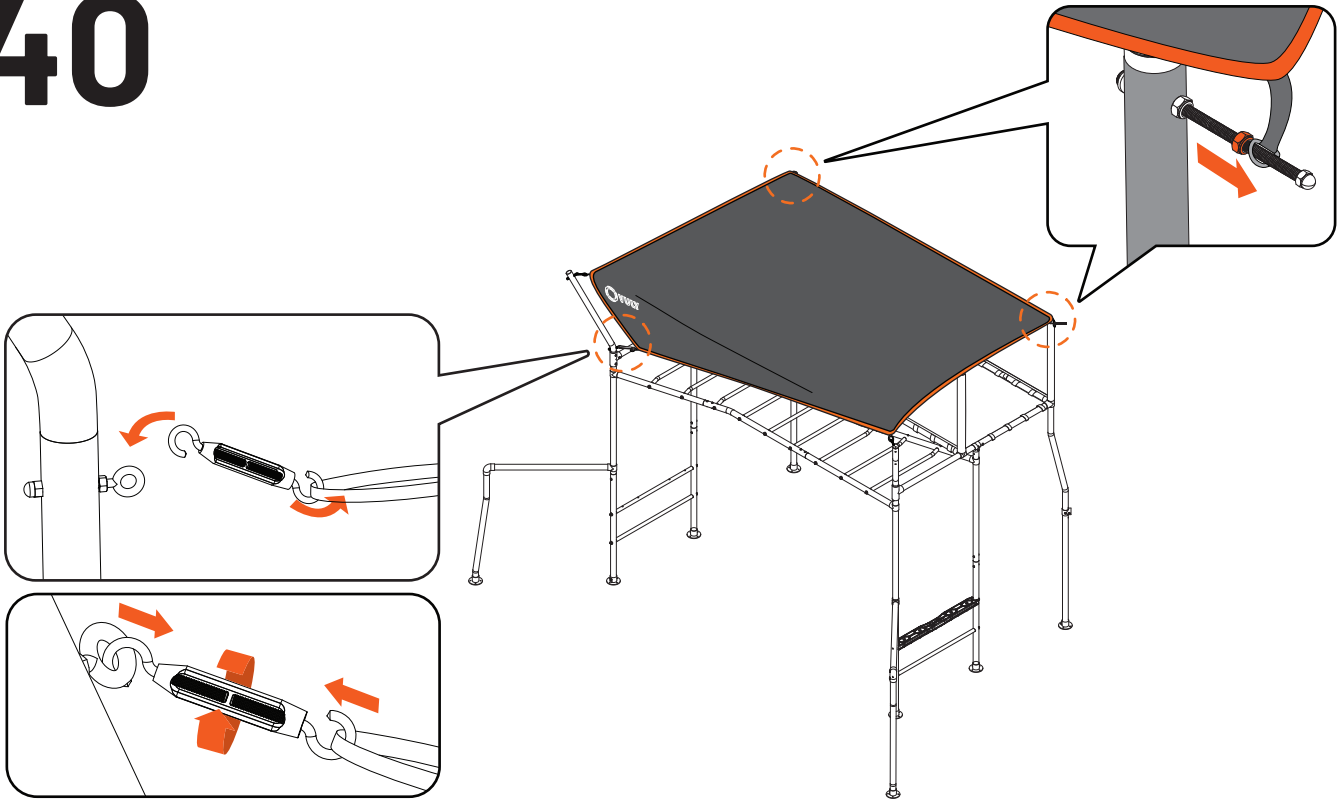

41

OPTIONAL

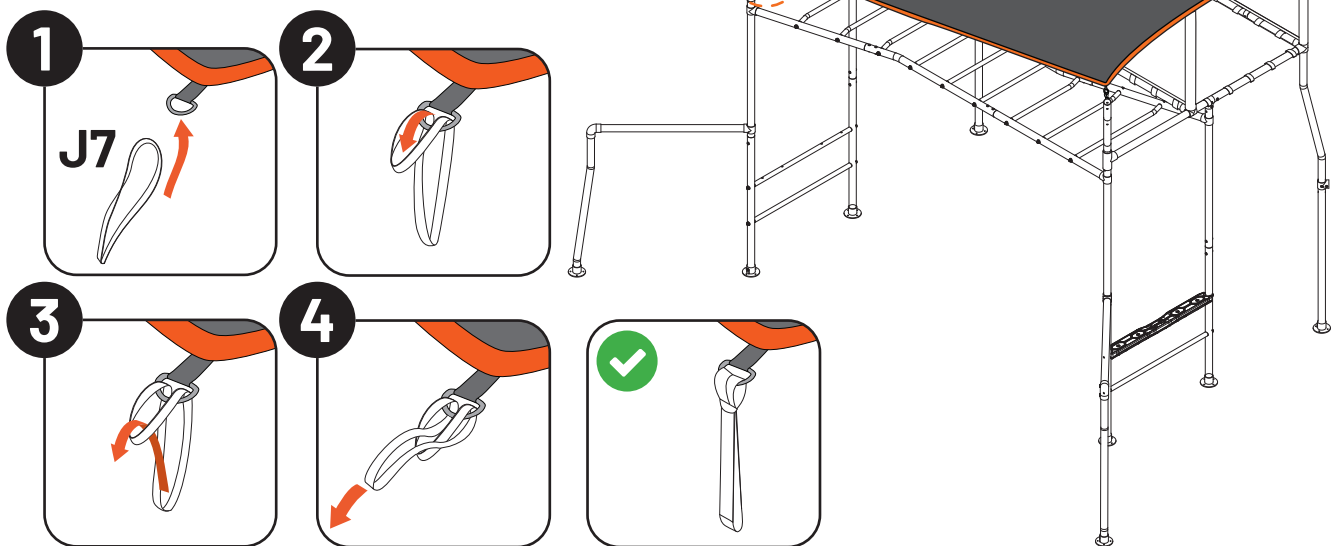

NOTE: If having difficulties connecting Turn Buckle to D Shackle, use the PP Webbing Loop provided as shown. **!**



42



43

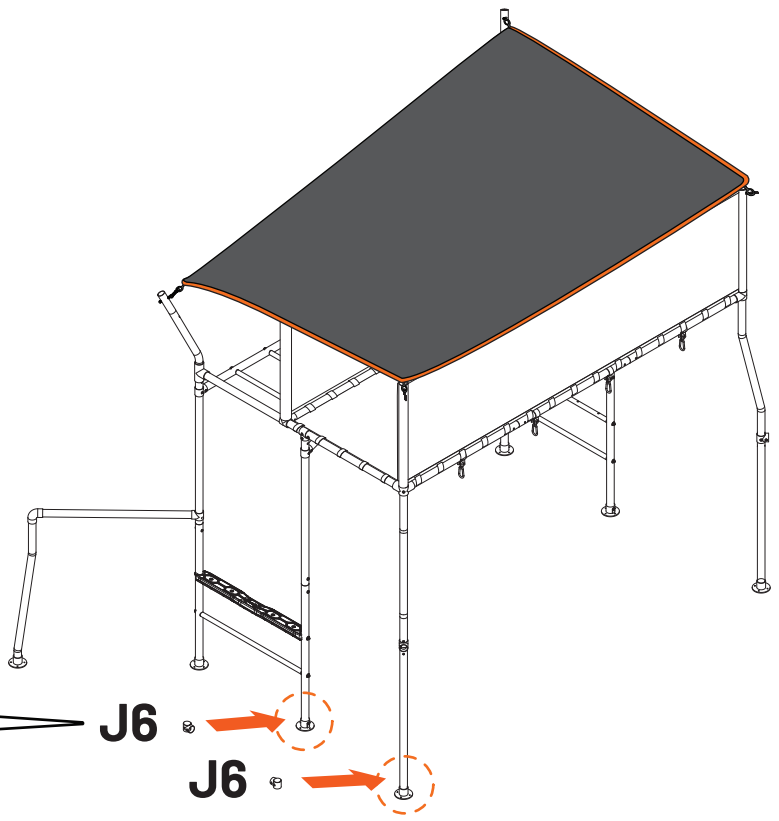
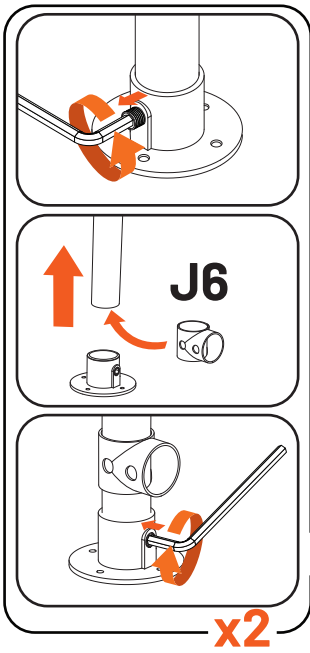

44

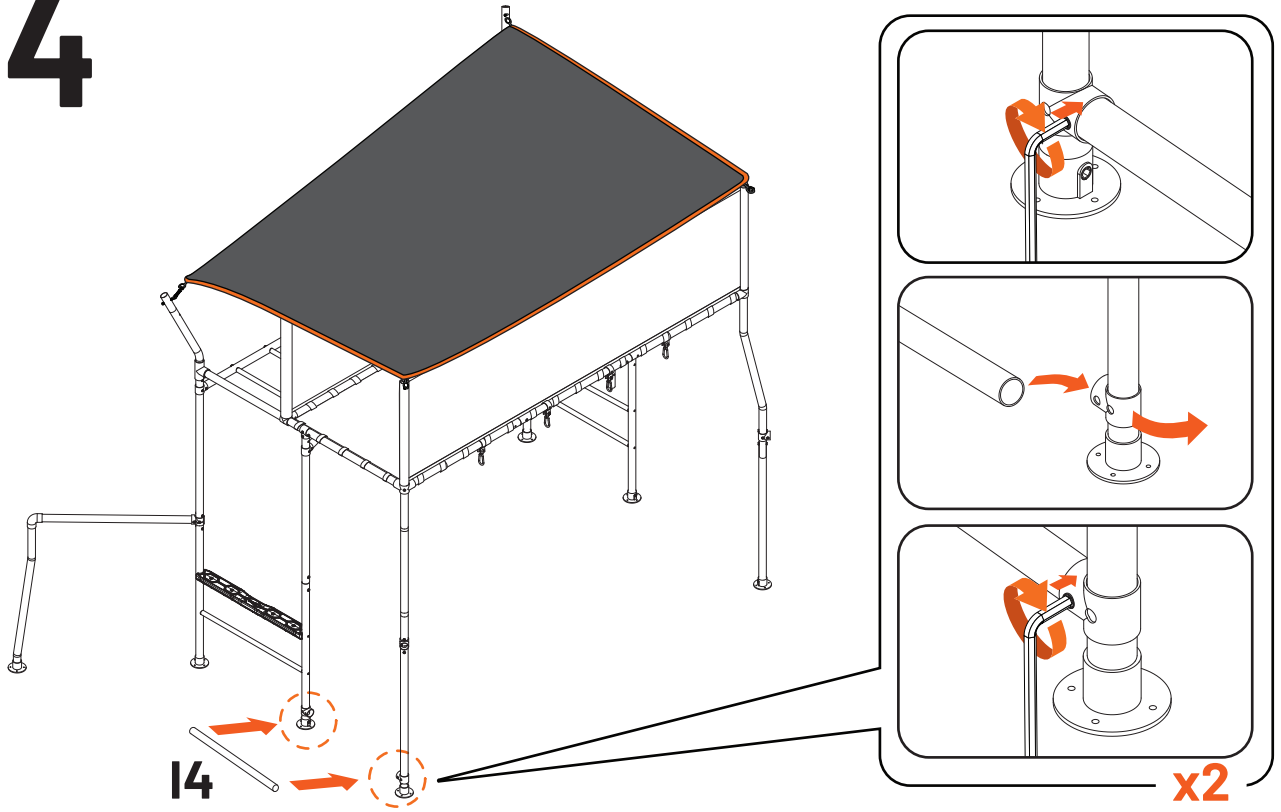

45

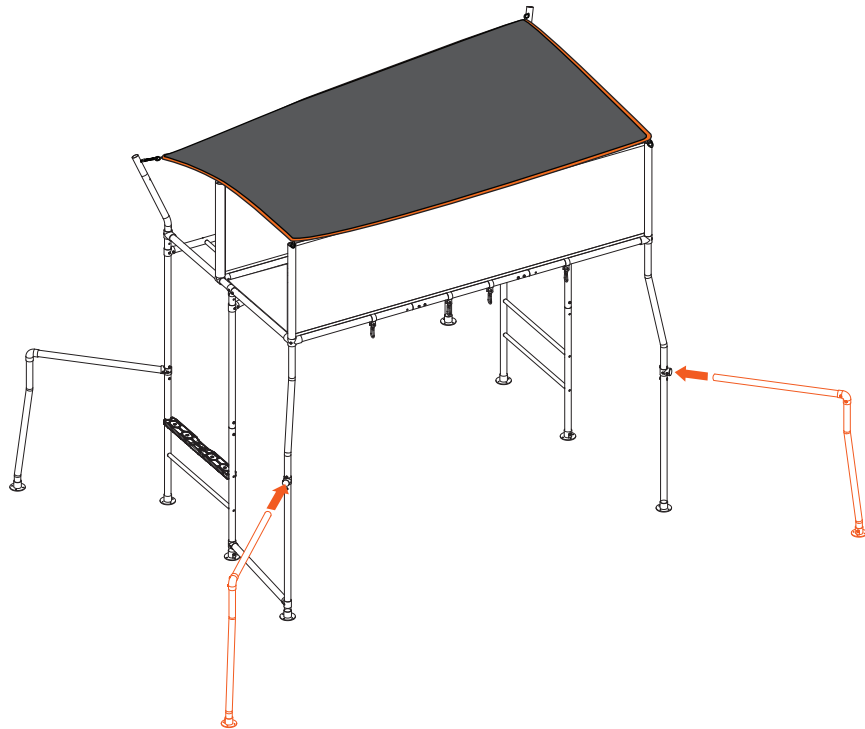

46

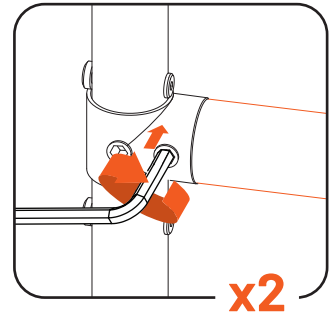
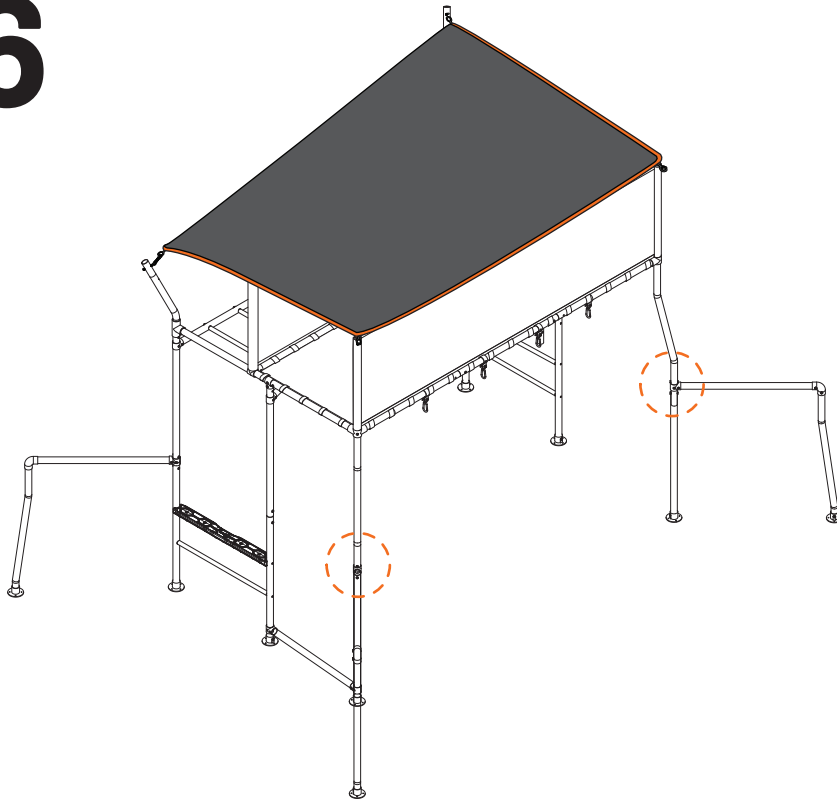

47

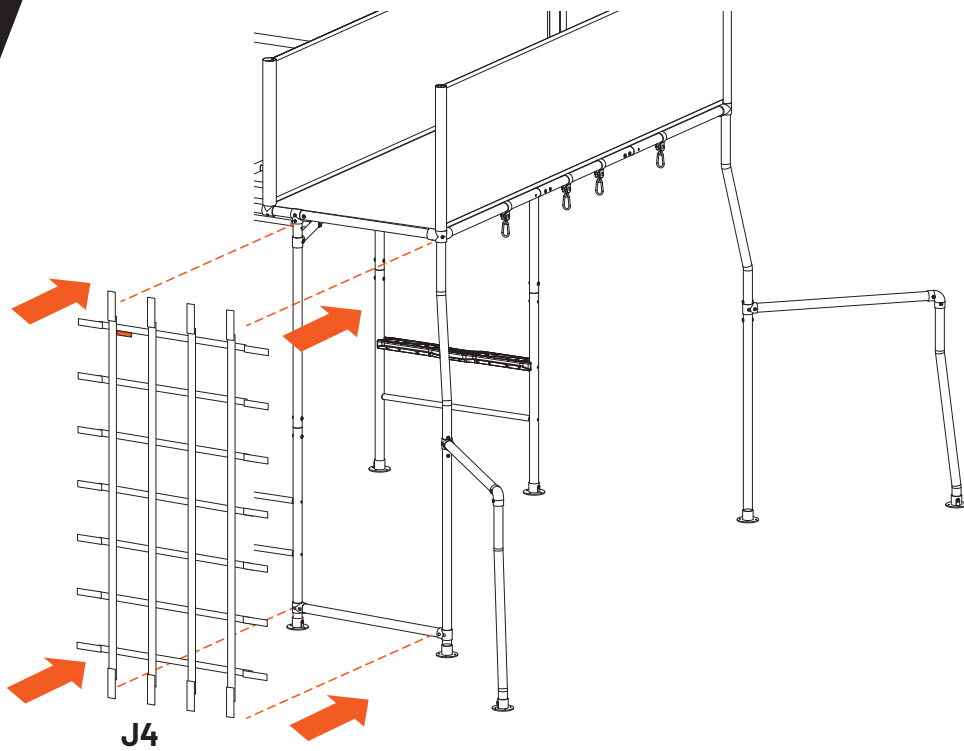

48

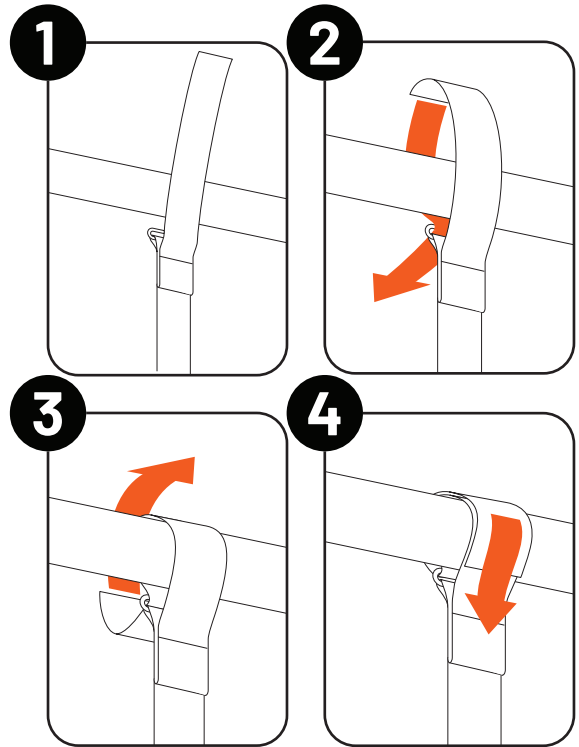
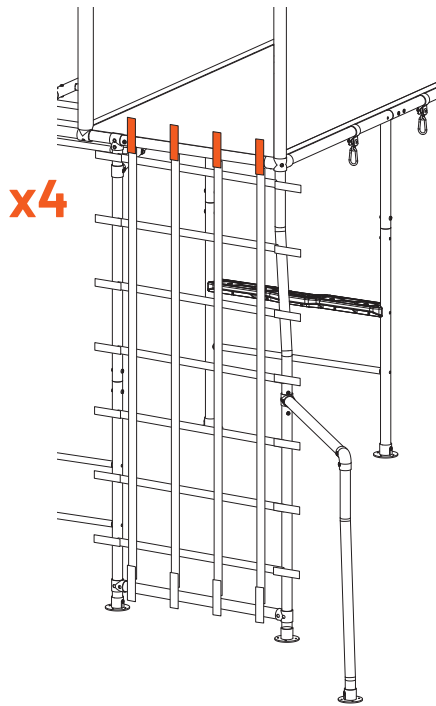

49

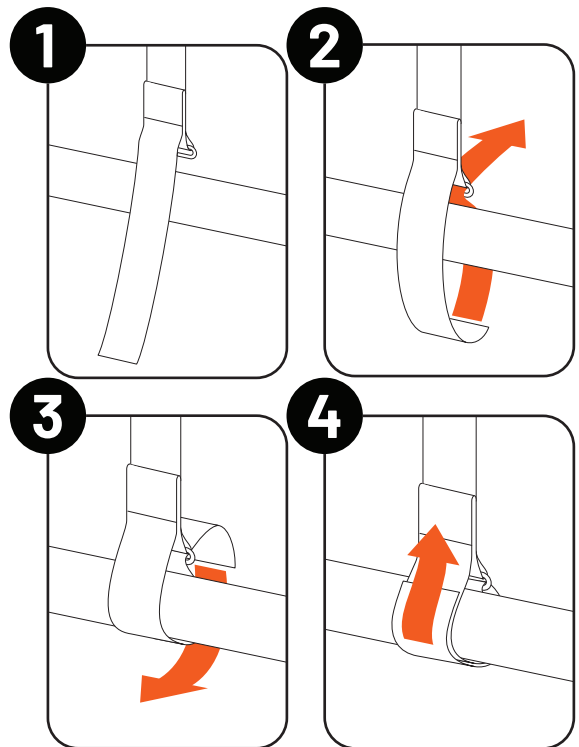
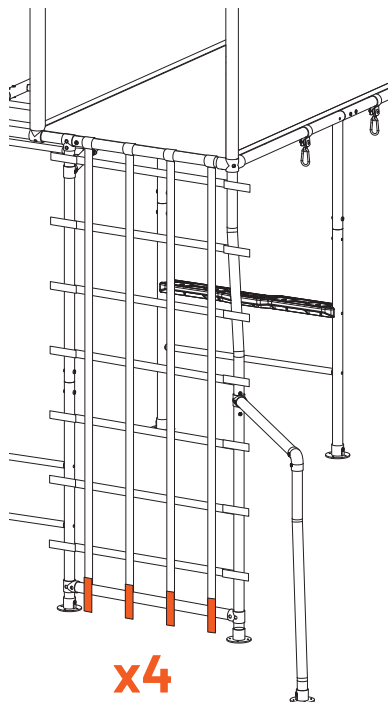

50

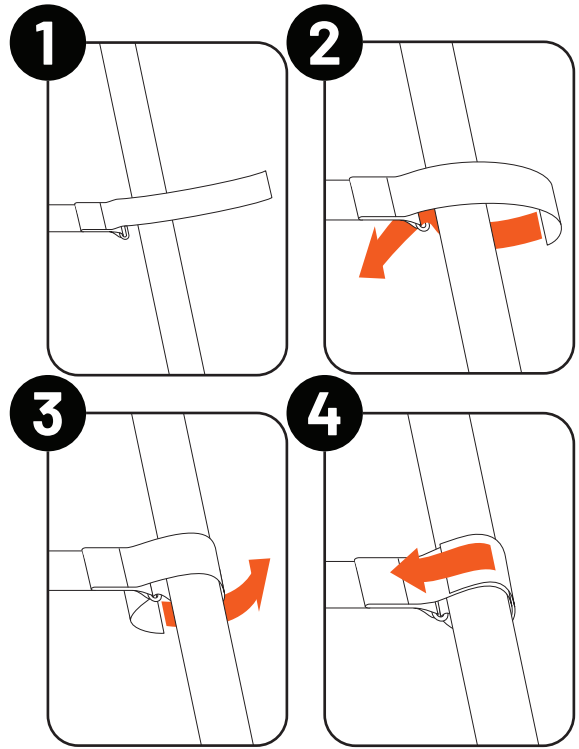
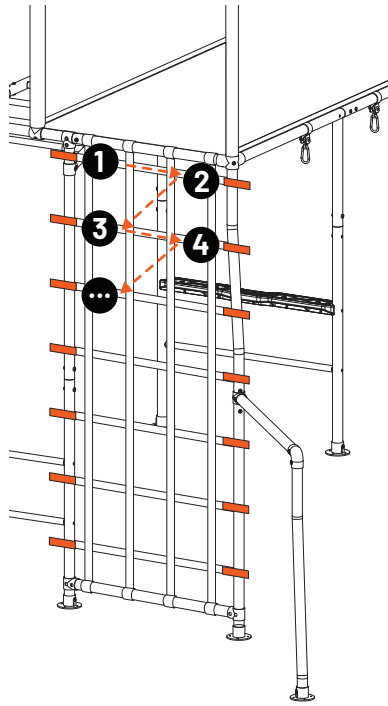

51

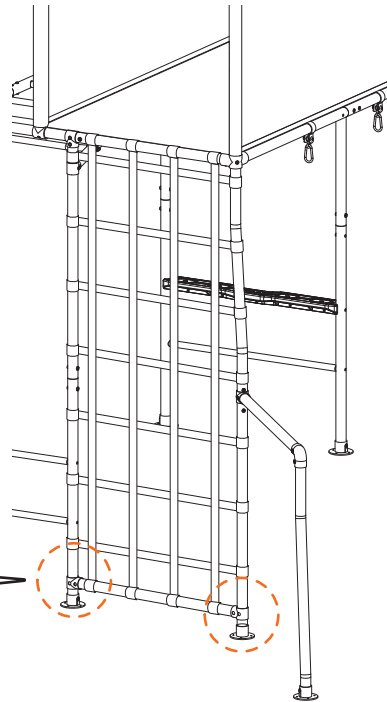
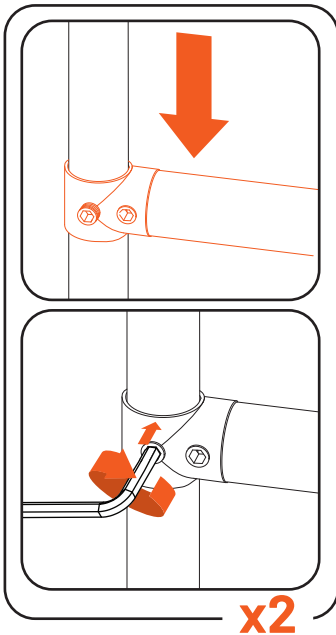

NOTE: Tension Cargo Net by push down on Joiners, then tighten Grub Screw to secure the assembly.



52

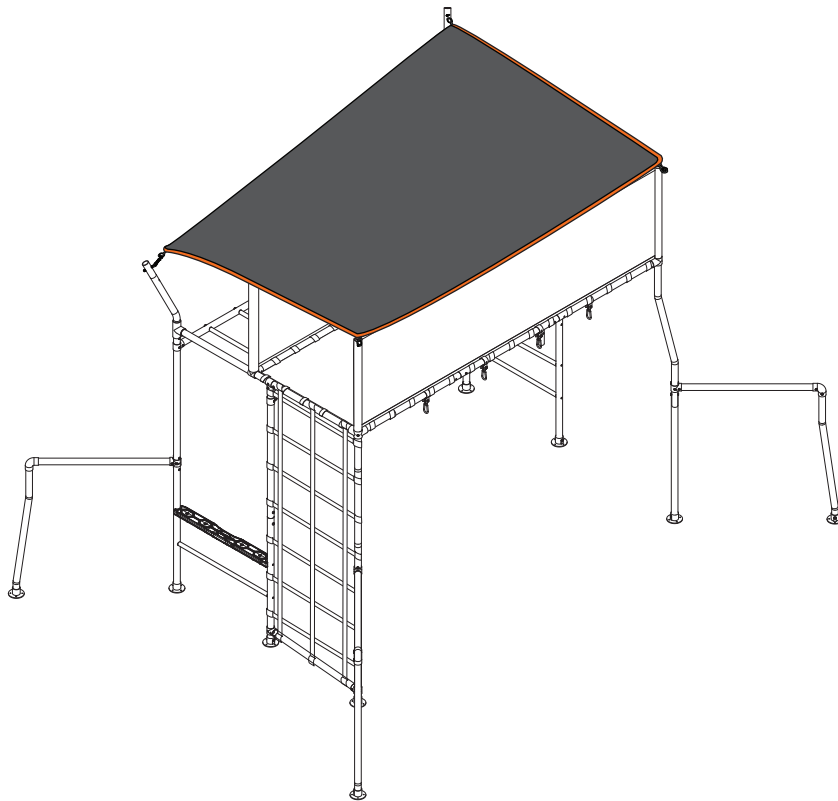
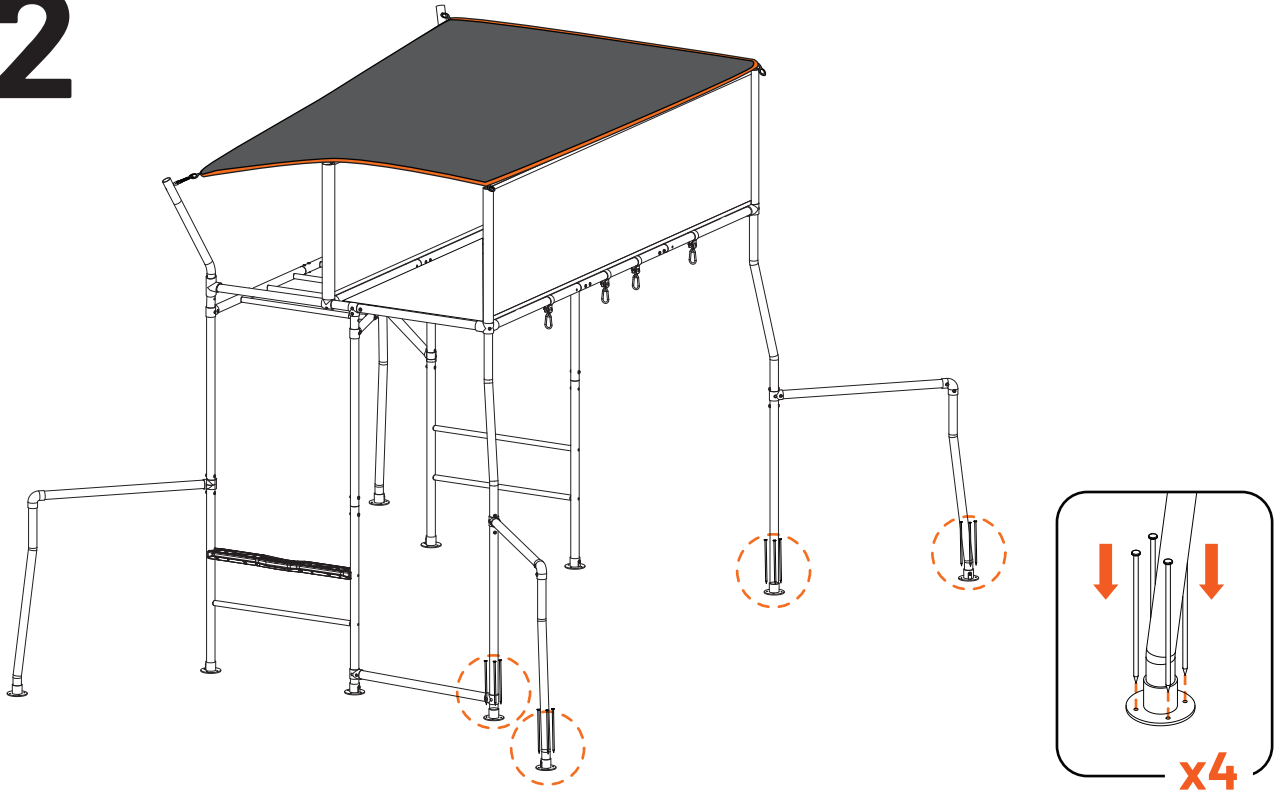

NOTE: Ensure all components and fasteners are securely installed.



CONGRATULATIONS!

You have assembled your Quest 1 Pro playset!



5.0. Product registration

To access the Half-Price Parts for Life programme or to lodge a Warranty Claim, customers must ensure that their Vuly product is registered with Vuly.

Customers who purchase directly from Vuly (through VulyPlay.us, at the Vuly Showroom or over the phone) automatically have their product registered.

Customers who purchase through an Authorised Reseller must register their product by visiting VulyPlay.us/Support and completing the form with a proof of purchase.

6.0. Half-price replacement parts

Vuly offers half-price replacement parts to all customers for the lifetime of their purchase through the Half-Price Parts for Life programme.

This programme is subject to change at any time, and it is only available to customers who have purchased either through an Authorised Reseller or directly through Vuly.

Half-Price Parts for Life is only available to customers who wish to replace parts that are core components of their system.

For the monkey bars, these parts include the following elements of the frame:

- Tubes
- Joiners
- Rails
- Bars

The programme does not extend to individual Ropes, Rings, Swings, Shade Covers or accessories.

7.0. Warranty

All Vuly products are sold with a manufacturing warranty, which assures that the item is free of defects in workmanship and materials (“warranty”).

7.1. Warranty periods

Warranty periods do not reset for any reason, unless the customer purchases a new product. In this case, that particular item will be covered by its own warranty period. It does not affect – nor will it increase – warranty periods for other purchased items.

Warranty periods always commence from the date of item delivery.

This warranty is for use under normal conditions, and it applies for:

Monkey Bars

- 84 months [7 years] to the frame components.

Accessories

- 24 months [2 years] to the Shade Cover.
- 12 months [1 year] to purchased accessories or attachments not received during a promotional period.

The customer may extend the standard 12-month [1 year] warranty to 36 months [3 years], if they purchase an extended warranty within 7 days of their delivery date.

7.1.1. Second-hand purchases

Vuly warranties apply only for the original purchaser, to a product purchased from Vuly Play or an Authorised Reseller. On-selling a Vuly product voids all warranties.

7.2. Inclusions

This warranty covers manufacturing faults and defects only.

If a product is damaged or rendered unsafe as a result of a departure from its design specifications during production, this constitutes a manufacturing fault or defect.

This may occur if – for example – improper welding produces an unstable Frame.

7.3. Exclusions

7.3.1. Damage through wear and tear

This warranty does not extend to normal wear and tear of the product. This may include, but is not limited to:

- Rusting or scratching of steel components,
- UV deterioration of textile components.

As outdoor products that are actively used, monkey bars and their accessories will experience wear and tear over time.

7.3.2. Damage through weather conditions

Damage to the product that results from weather events – such as rain or wind – are not covered under the warranty. Vuly suggests that you contact your home and contents insurer if your product is damaged by such events.

7.3.3. Damage through improper installation

This warranty does not extend to any failure of the product caused by installation not in accordance with the Vuly Manual. Customers must assemble their Vuly product by following carefully the Installation section of their Vuly Manual.



Furthermore, the warranty does not cover installation provided by a third-party assembly service. It is the customer's responsibility to check all boxes and confirm that all components are included in the correct condition before installing.

7.3.4. Damage through insufficient care or maintenance

This warranty does not extend to accelerated decay of the product caused by poor care or maintenance. It is essential that customers regularly check, and follow the advice of, the Care and Maintenance section of their Vuly Manual to ensure that their product lasts as long as possible.

7.3.5. Damage through inappropriate use

This warranty will be void if the product is used for any other activity besides those for which it was intended, or used in any way that is unadvised in this Manual. Vuly products constitute recreational outdoor products and accessories for such products. They are not intended for professional use.

Any evidence that inappropriate actions that have led to product failure will not be covered by the warranty. Similarly, replacement parts or repairs needed to mend such damage will not be covered under the warranty.

7.3.6. Damage through salt water proximity

This warranty (on steel components, specifically) will be reduced by 50% where the Vuly product is assembled within 1.6 km of a salt water environment or where it is subject to ocean spray.

7.3.7. Personal Injury

The warranty does not cover personal injury or losses due to any of the above: wear and tear, weather conditions, inappropriate installation, insufficient care or maintenance or inappropriate use, nor does it cover damage due to negligence or accidents.

7.3.8. Installation

This warranty does not cover any installation service. If a customer pays for installation of their Vuly product at the time of purchase, this is a one-time service only. The customer may not claim installation costs for any replacement parts.

7.4. Warranty Claims

If a customer believes that a Vuly product is faulty or defective, they must discontinue use and submit a Warranty Claim.

A customer must not attempt to use a product if any part is faulty or defective, as it may be dangerous. Any damage that the user causes as a result of using faulty or defective products will lead to voiding of the warranty.

7.4.1. Making a Warranty Claim

To fulfill a warranty claim, a customer must submit an online Warranty Claim at VulyPlay.us/Support.

Submitting the online Warranty Claim form requires the customer to provide:

- Details of their purchase – including date,
- Batch number,
- Clear photographic evidence of the manufacturing fault or defect.

If the customer does not provide all details that the form requires, their Warranty Claim will not be assessed.

Vuly may take up to 7 days to process Warranty Claims upon a completed submission. It may take a further 7 days for replacement parts to reach the customer.

7.4.2. Successful Warranty Claims

If Vuly accepts a customer's Warranty Claim, Vuly will replace the faulty or defective parts, or offer refunds depending on the severity of the issue.

Successful Warranty Claims lodged within 60 days of the delivery date:

Vuly will replace the damaged parts free of charge. Vuly will also cover any costs associated with shipping the replacement part.

Successful Warranty Claims lodged after 60 days of the delivery date:

Vuly will replace the damaged parts free of charge. The customer must cover any costs associated with shipping the replacement part.

7.4.3. Walk-in Warranty Claims

If a customer wishes to make a Warranty Claim while on the Vuly premises, they must first submit an online Warranty Claim at vulyplay.us/support – providing all required details.

7.4.4. Refunds

If Vuly accepts a customer's Warranty Claim, Vuly will replace the faulty/defective parts or offer refunds depending on the severity of the issue.

Refunds will typically be processed within 7 days after the refund has been improved. Vuly provide this timeframe in good faith, we shall not be held accountable should this timeframe not be met.

7.4.5 Claiming on non-Vuly products

Products sold alongside Vuly that are not Vuly-branded are subject to the warranties provided by the companies that supply them. The customer must contact these external companies to make a warranty claim; Vuly itself will not assess claims made against non-Vuly products.



7.5. Consumer Law

Our goods and services come with guarantees that cannot be excluded under the Uniform Commercial Code (“UCC”).

For major failures with the service, you are entitled:

- to cancel your service contract with us; and
- to a refund for the unused portion, or to compensation for its reduced value.

8.0. Missing parts

If a customer believes that a Vuly product does not include all necessary parts, they must immediately lodge a Missing Parts Claim at vulyplay.us/support.

A customer must not attempt to use a product if any part is incomplete, as it may be dangerous. Any damage that the user causes as a result of using incomplete products will lead to voiding of the warranty.

Vuly products are delivered to Vuly warehouses prepackaged; we are unable to check the boxes prior to delivery to ensure that they contain all the required parts. While the missing part rate during packing is very low, some parts may also fall out in transit due to small, unintentional tears in their boxes.





vulyplay.us

See vulyplay.us/terms for the most recent Vuly warranty policies, terms and conditions.

