



MANUAL **M**

ATTENTION!

SAFETY INFORMATION, INSTALLATION, CARE AND MAINTENANCE INSTRUCTIONS. READ PRIOR TO ASSEMBLING AND USING THE TRAMPOLINE.

Vuly cares about safety. Adult supervision is required at all times whilst equipment is in use.

If you have any feedback regarding our instructions, feel free to email instructions@vulyplay.com so that we can continue to improve.



Visit www.vulyplay.com/install

for step by step video instructions, or scan this QR code:



Contents

Read and follow all instructions in this manual before using your trampoline, and do not use the trampoline in any way that is not described in this manual.

Responsibility rests with the owner and supervisors of the trampoline to make sure that all users are aware of the practices specified in this manual.

1.0. Disclaimer.....	3
2.0. Care and Maintenance.....	4
2.1. General care	4
2.2. Rust and corrosion.....	4
2.3. Textile deterioration	4
2.4. Weather care.....	4
2.5. Relocation.....	4
2.6. Inspection checklist.....	4
3.0. Usage and Behaviour.....	5
3.1. Safe use information	5
3.2. Safe use instructions	5
3.3. Basic trampolining instructions.....	5
4.0. Installation.....	6
4.1. Location planning.....	6
4.2. Pre-assembly instructions	6
4.3. Parts and components	7
4.4. Assembly instructions.....	9
5.0. Product registration	33
6.0. Half-price replacement parts.....	33
7.0. Warranty	33
7.1. Warranty periods.....	33
7.2. Inclusions	33
7.3. Exclusions	33
7.4. Warranty Claims	34
7.5. Australian Consumer Law	35
8.0. Missing parts.....	35

1.0. Disclaimer

The following Conditions of Sale will apply to, and bind the purchaser of, any Vuly Trampolines Pty. Ltd. ABN: 91 160 793 706 product.

NOTICE TO USER:

Please read this agreement carefully before purchase or assembly. By purchasing, opening and assembling this product you acknowledge that you have read this agreement, understand it and agree to be bound by its conditions. If you are making a purchase on behalf of another person, you agree that you are making the purchase as their agent.

LEGAL RIGHTS – PLEASE READ:

EXCLUSION OF LIABILITY – WAIVER OF RIGHT TO SUE – YOUR ASSUMPTION OF RISK – THESE CONDITIONS AFFECT YOUR LEGAL RIGHTS.

Vuly Trampolines Pty. Ltd. ABN: 91 160 793 706 (“Vuly”), as supplier of trampolines and accessories (“Products”), sells all Products subject to the following conditions:

1. To the maximum extent permitted by the law, Vuly, its employees, directors and agents will not be liable to the customer, their dependents or legal representatives for damage to property, personal injury or death suffered by the customer because the Product was not manufactured or supplied with due care and skill, the Product is not reasonably fit for its purpose or because of negligence, breach of contract, breach of statute or breach of statutory duty by Vuly.

2. Vuly, its employees, directors and agents are not liable to the customer, their dependents or legal representatives for personal injury or death suffered by the customer because the Product was not:
- installed in accordance with the Vuly instruction manual. It is the customer’s responsibility to check all boxes to confirm that all components are included and in the correct condition before assembly.
 - installed with due care and skill, by a the customer or a third party assembly service; and
 - in the same condition as when the Product was supplied, due to wear and tear – including, but not limited to, weather damage, deterioration of the net, spring stretch, UV deterioration or rust.
3. The customer acknowledges that using the Product can be dangerous, with inherent risks and hazards. As a consequence, personal injury or death may occur. The customer assumes and accepts all such risks, and hereby – to the full extent permitted by law – waives the right of action against, and fully releases Vuly for, loss, damages, personal injury or death in any way caused by, or relating to, the customer’s participation in such activities.

This includes – without limitation – liability for any negligent or tortious acts or omission, breach of duty, breach of contract or breach of statutory duty on the part of Vuly, its office bearers, directors, employees or agents.

RISK WARNING:



The use of the Product involves a significant risk of participants suffering personal injury including the possibility of serious injuries, permanent disability or death. All participants who engage in activities with the Product do so at their own risk.



WARNING:

To reduce the risk of injury while using the system, enforce the following:

- One user at a time - collision hazard.
- 100kg weight user Maximum
- Only use outdoor and Domestic use
- Adult supervision required at all times. Users 6 years of age & over.



ADULT SUPERVISION IS REQUIRED AT ALL TIMES WHILST EQUIPMENT IS IN USE.
VULY CARES ABOUT SAFETY.

2.0. Care and Maintenance

Improper maintenance or lack of care can lead to your trampoline deteriorating earlier than expected. Please follow these care instructions to ensure that your trampoline lasts for as long as possible.

Consumers must not modify the original trampoline, unless carried out according to Vuly instructions.

2.1. General care

- Retain this Manual.
- Inspect before and after each use. It is essential that you replace any worn, defective or missing parts immediately and only through Vuly.
 - See 2.6 Inspection checklist.
- Ensure that the Safety Net is always correctly attached and in good condition.
 - Replace the Safety Net every 1 year.
- Keep away objects that could damage textile components.
- Ensure that moving steel components remain well lubricated.
- Check that all spring-loaded joints remain intact and cannot become dislodged during use.
- Use only Vuly-made accessories.
- Use only parts that are recommended by Vuly.

2.2. Rust and corrosion

- Be aware of areas that are particularly prone to rusting:
 - Places where water is easily trapped.
 - Hollow sections of steel (which can appear in good condition on the outside, while hiding rust on the inside).
 - Sections where steel components join together.
- Inspect the inside of all Frame Tubes and Net Poles every 6 months – as well as after rain – and remove any water from the inside surfaces.
- Check Frame Tube and Net Pole connection areas for rust.
- Use general-purpose grease on steel connection areas.
- Avoid cleaning steel components excessively; it may reduce the effectiveness of our protective coatings.

2.3. Textile deterioration

- Clean your Jump Mat with a soft sponge only, to avoid prematurely wearing the textiles.
- Avoid using powerful soaps or detergents; they can damage the textiles.
- Wipe dry with an absorbent cloth any water left after rain, cleaning or use of the Vuly Mister accessory. The Jump Mat may discolour or form spots, if left to dry in the sun.
- Inspect the inside of your Safety Padding (if applicable) regularly, and remove any water through the drainage holes.
- Remove textile parts, and store them – in their original packaging – in a cool, dry and dark place when the trampoline will be unused for over 1 month. Prolonged exposure to UV sunlight can shorten the lifespan of the Safety Net.

2.4. Weather care

Components of this trampoline are susceptible to deterioration from use and environmental conditions – such as sunlight, rain, salt and heat – to varying degrees.

If your trampoline will be unused for any extended period, disassemble it, return it to its original packaging and store it in a dry place.



RAIN: Remove any fallen debris on your trampoline after rain and wipe off residual water with a dry cloth. Moisture left on the trampoline may contribute to the corrosion of steel components and weaken textiles.



WIND: Disconnect the Safety Net from the Net Poles, and cover the Safety Net and Jump Mat with a storm cover.



COLD: Disassemble your trampoline and store the Jump Mat and Safety Net indoors.



HEAT: Move your trampoline to where it will receive the most shade during the brightest times of the day. Cover when not in use to minimise UV damage.

In certain countries during the winter period, the snow load and the very low temperature change can damage the trampoline. It is recommended to remove the snow and store the *mat* and the *enclosure* indoors; checking that the mat, padding and enclosure are without defects.

2.5. Relocation

- Move the trampoline with a minimum of 4 adults, to ensure that the lift is within heavy lifting regulations.
- Move the trampoline short distances using the official Vuly Wheels accessory for your trampoline model. Remove after use.
- Do not drag the trampoline. Parts may bend or warp if insufficiently lifted.
- Avoid tilting the trampoline or resting it on its side; the frame may bend under its own weight.
- Disassemble the trampoline, and return it to its original packaging, to transport it over long distances.

COMPONENTS WILL DETERIORATE OVER TIME.

Note: *Sunlight, rain, snow and extreme temperatures reduce the strength of components over time.*

Record your date of purchase here:

	/	/
--	---	---

2.6. Inspection checklist

Use this checklist to inspect your trampoline before each use. Replace any worn, defective, or missing parts to avoid potential hazards.

If you discover any safety issues, do not use the trampoline. Contact Vuly to order and replace any parts.

Frame

- Bends, cracks, twists or breaks
- Rust spots
- Sharp protrusions

Springs

- Missing, broken or damaged springs

Safety Padding

- Missing, improperly positioned or insecurely attached Safety Padding
- Punctures, frays, tears or holes
- Deterioration of, or damage to, the stitching or fabric

Jump Mat

- Punctures, frays, tears or holes
- Deterioration of, or damage to, the stitching or fabric
- Sagging fabric
- Sharp protrusions in the suspension system elements
- Rusting, damaged or bent mat connector steel
- Broken mat connector plastics

Safety Net

- Missing, improperly positioned or insecurely attached Safety Net
- Punctures, frays, tears or holes
- Deterioration of, or damage to, the stitching or fabric of the enclosure barrier or connectors
- Sagging fabric
- Broken or damaged entry system

Net Poles

- Missing, improperly positioned or insecurely attached:
 - A. Net Pole supports
 - B. Net Pole U-shackles
- Bends, cracks, twists or breaks
- Rust spots
- Sharp protrusions

3.0. Usage and Behaviour

Improper use of, or behaviour on, your trampoline can lead to serious injury. Please follow these usage and behaviour instructions to ensure safe play.

3.1. Safe use information

- Maximum user weight: 100 kg.
- Domestic and outdoor use only.
- Suitable for ages 6 and over.

WARNING:

- Only one user. Collision hazard.
- Always close the net opening before jumping.

3.2. Safe use instructions

To reduce the risk of injury while using the trampoline, enforce the following:

- Ensure that the trampoline has been assembled by an adult, in accordance with the assembly instructions, and been checked over before first use.
- Do not bounce in strong wind conditions or inclement weather, and keep the trampoline secure.
- Ensure active and competent adult supervision at all times while children are using the trampoline. Children are often unable to identify hazards or properly assess risk.
- Avoid eating or drinking while bouncing.
- Empty pockets and hands before bouncing.
- Wear comfortable clothing that allows full and free movement.
 - Do not wear jewellery, drawstrings, cords, loops, buckles or anything that could entangle in trampoline components and become a strangulation hazard, a contact hazard or damage the trampoline.
- Remove shoes, as they may damage the bed and increase the risk of injury.
- Climb on and off the trampoline. Never jump or bounce off.
- Refrain from using the springs as 'hand grips' when getting onto or off the trampoline.

- Do not allow children, pets, toys or other play equipment underneath the trampoline. Make sure that the areas around, underneath and above the trampoline are clear.
- Learn fundamental bounces and body positions before trying more advanced manoeuvres.
- Demonstrate safe use for children before allowing them onto the trampoline.
- Contact Vuly or an Authorised Reseller for further information or additional instructional material.
 - To learn more advanced trampolining skills, contact a suitable gymnastics or trampoline club.

3.3. Basic trampolining instructions

This trampoline is a domestic model, not a gymnastics trampoline. You will get the safest and best use from it by following these basic principles:

- Do not attempt or allow somersaults on the trampoline. Landing on your head or neck while doing somersaults can cause serious injury, paralysis or even death.
- Do not use the trampoline when wet. The Jump Mat will be slippery and make landing less secure.
- Do not allow users to intentionally bounce into or over the Safety Net, as this can unbalance the trampoline and continual impact may damage the enclosure. Always jump in the middle of the Jump Mat.
- Do not use a trampoline while under the influence of alcohol or drugs. Balance, perception and assessment of risk will be affected and may lead to injury.
- Do not use the trampoline as a springboard to other objects. Use the trampoline only for trampoline-style bouncing.
- Focus your eyes on the edge of the trampoline. This will help control your bounce.
- Stop your bounce by flexing your knees as your feet come in contact with the trampoline bed. Learn this skill before you attempt any others.
- Avoid bouncing too high. Stay low until you can control your bounce and repeatedly land in the centre of the trampoline.
- Do not bounce immediately after a meal.
- Limit the time of continuous usage.

4.0. Installation

4.1. Location planning

- Do not bury the trampoline into the ground.
- Place the trampoline on a flat, level surface with impact attenuating properties – such as grass.
- Ensure that the trampoline is sufficiently stable, to prevent the trampoline from tipping over or blowing away. Sandbags or pegs may be suitable anchorage devices.
- Keep a minimum of 8 m overhead clearance, when measured from the bed height, to prevent users from inadvertently contacting overhead hazards – such as electric wires, tree limbs and clotheslines.
- Maintain a minimum clearance of 2 m on all sides of the trampoline. This area should not include concrete, bitumen, brick or other hard surfaces, as these can cause serious injuries if users fall off the trampoline.
- Do not locate the trampoline on top of other objects or store anything underneath the trampoline bed.
- Keep the area around and underneath the trampoline clear. Place the trampoline away from walls, structures, fences and other play areas.
- Place the trampoline in a well-lit area.

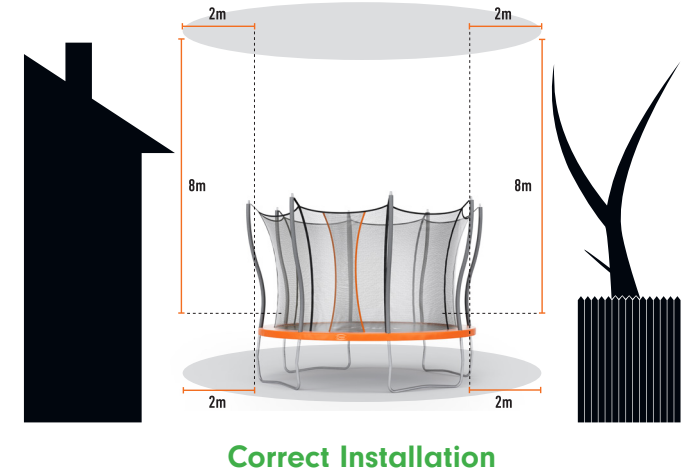

4.2. Pre-assembly instructions – Vuly Flare M

PRE-ASSEMBLY

- Find level ground, and make sure that there are no obstructions nearby.
- Check that you have all the parts required for assembly.

REMEMBER: WEAR THE VULY GLOVES AT ALL TIMES WHEN INSTALLING YOUR TRAMPOLINE.

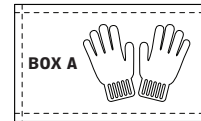

TIME REQUIRED FOR ASSEMBLY: 1 HOUR (APPROX).
NUMBER OF PEOPLE REQUIRED FOR ASSEMBLY: 2

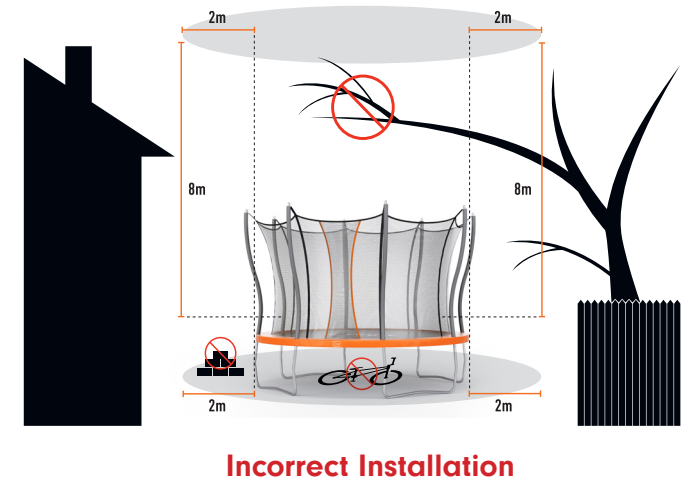

4.3. Parts And Components

BOX A

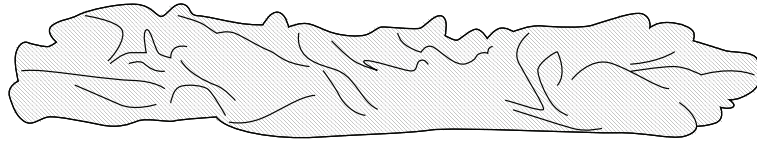

X 1 SAFETY NET

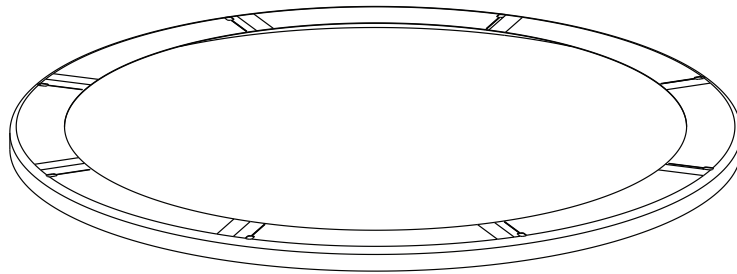

X 1 SAFETY PAD

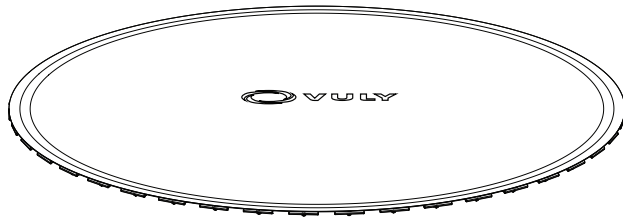

X 1 JUMPING MAT

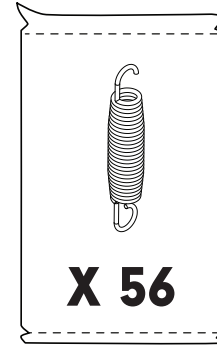

X 56
SPRING SET



X 1
SPRING TOOL

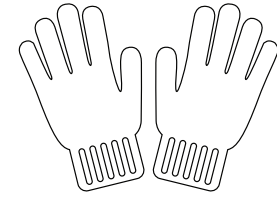

X 1
INSTALLATION GLOVES

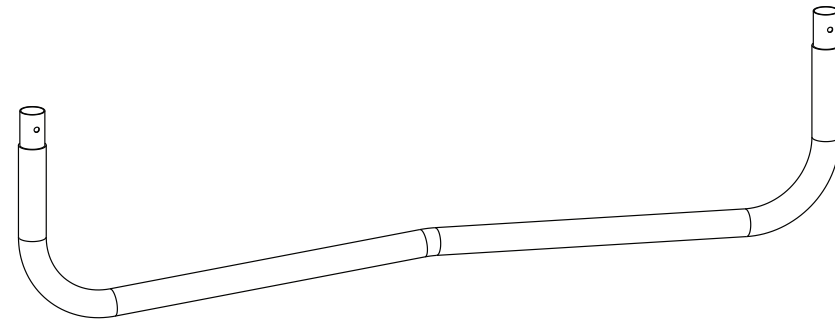

X 4 W-POLE



X 3 UPPER NET POLE

BOX B

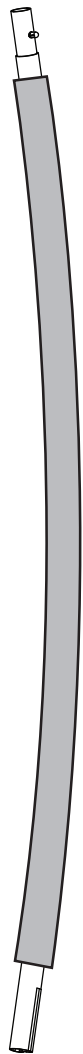

X 5
UPPER NET POLE



X 8
CURVED POLE



X 8
LOWER NET POLE

BOX C

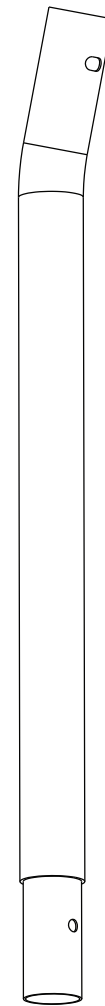

X 8
STRAIGHT POLE

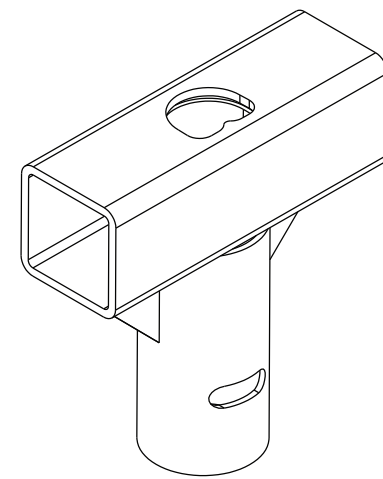

X 8
T-JOINER

4.4. Assembly Instructions

1

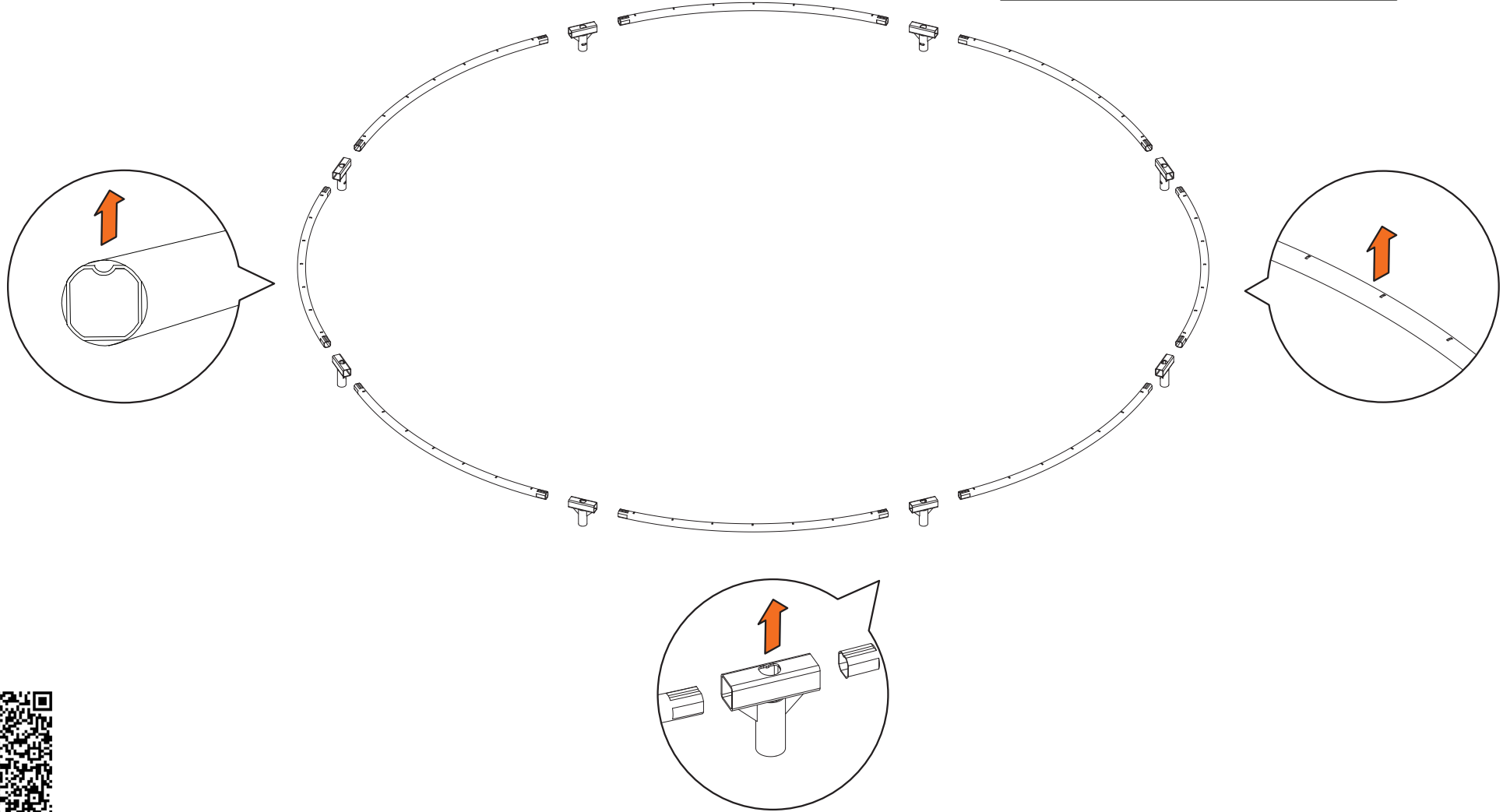
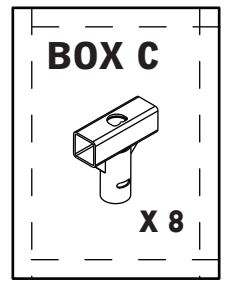
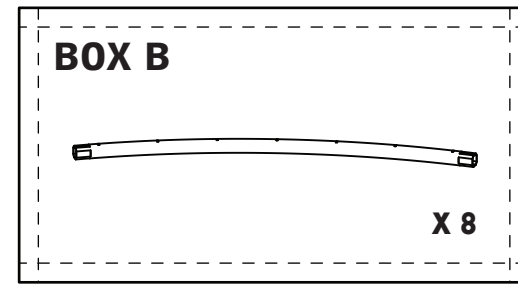

NOTE: Push button hole should face inwards.



2

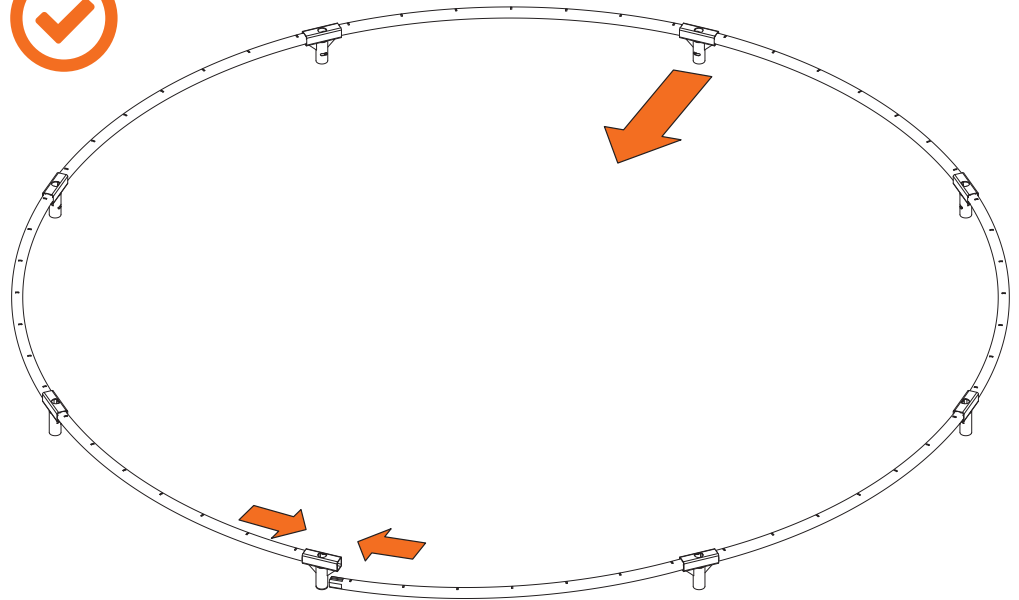
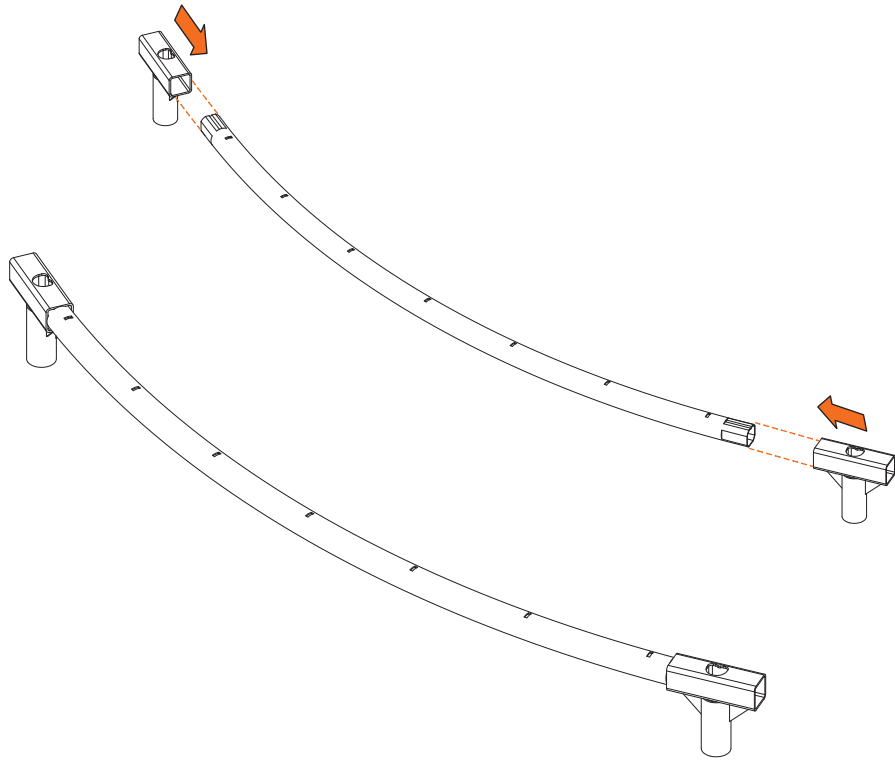

TIP: Have one person in opposite position to help insert the final Frame Tube into the Joiner.



3

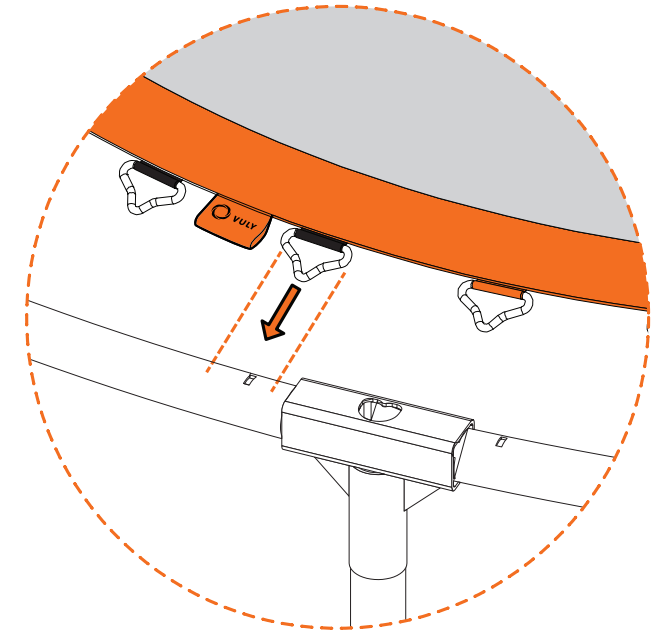
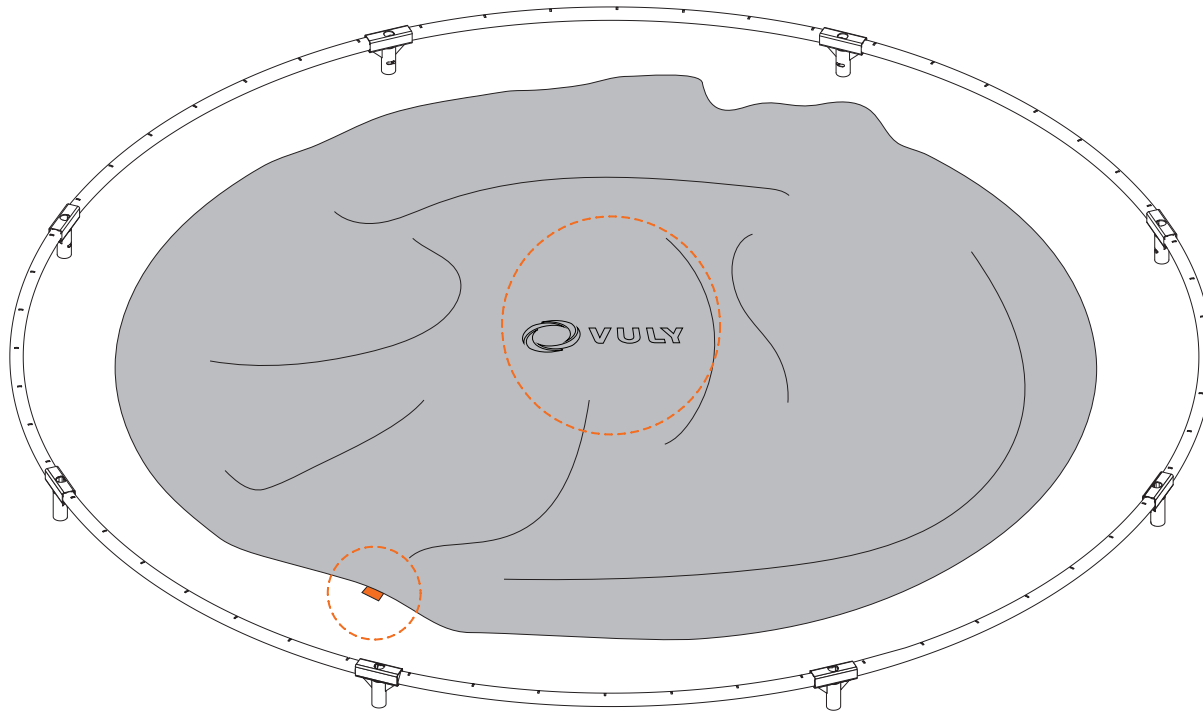
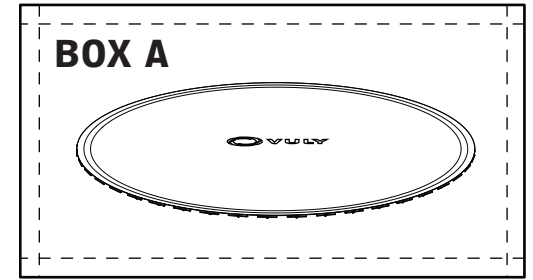

TIP: Ensure the Vuly logo is facing upwards. Locate the Batch Tag; the Batch Tag will be to the left of the entrance to the trampoline.



4

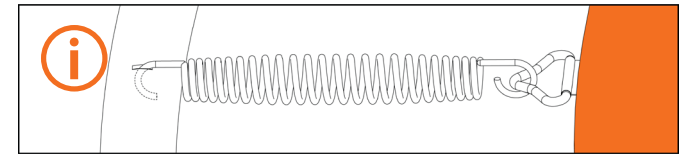
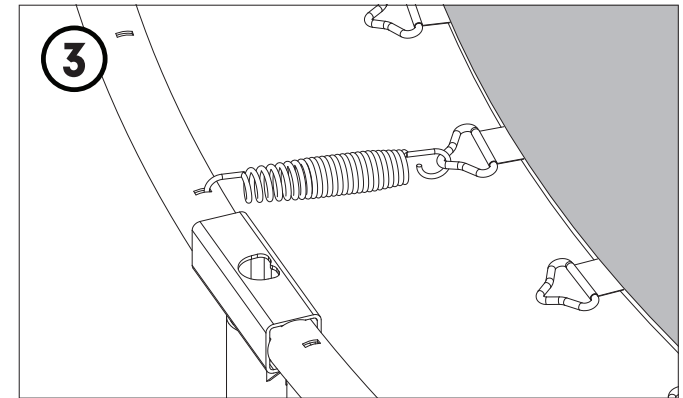
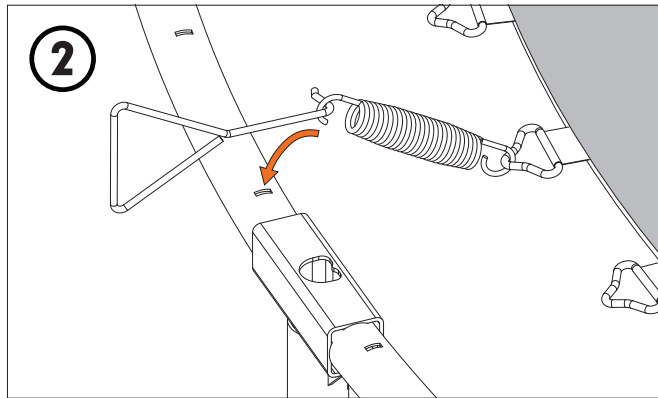
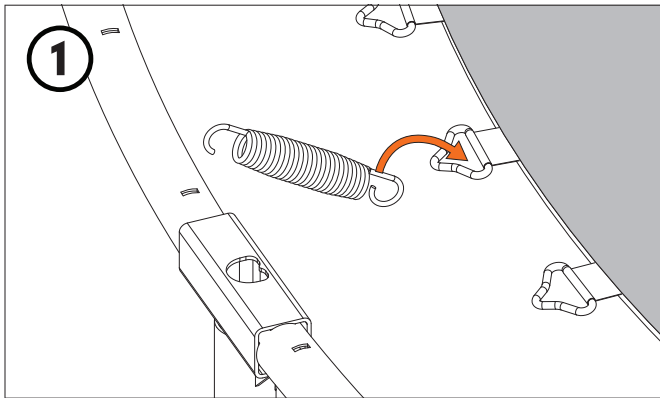
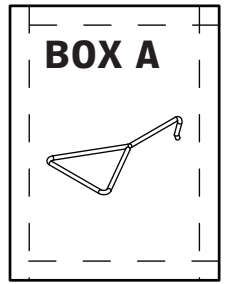
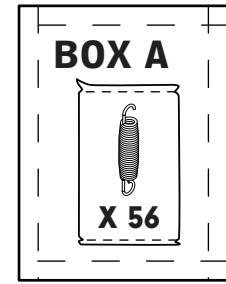
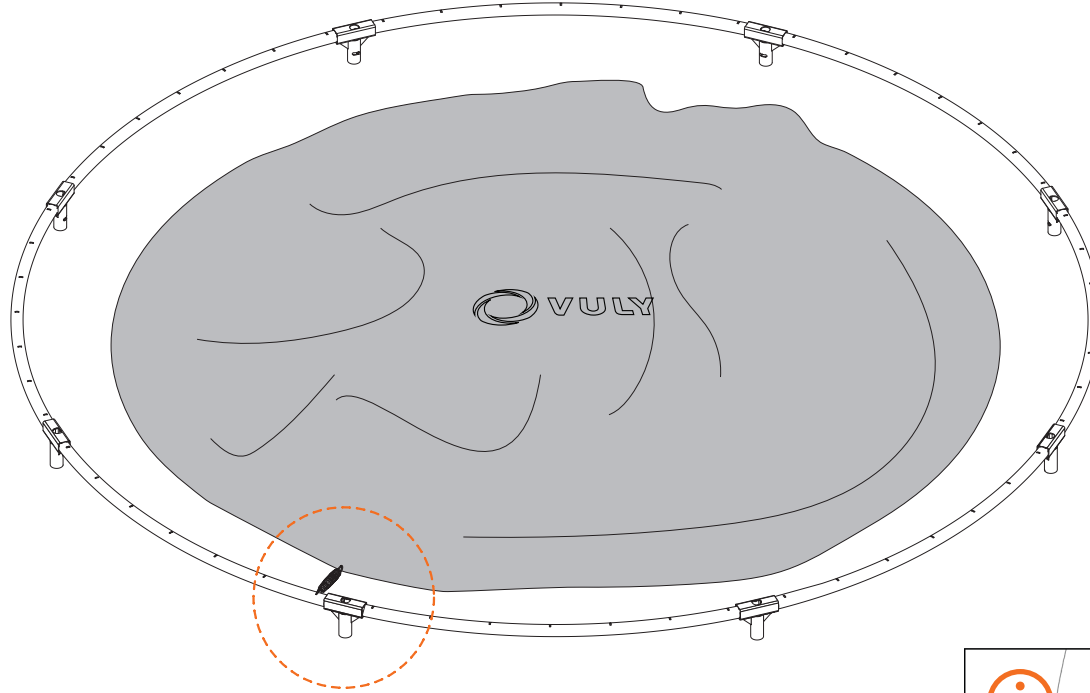

 **NOTE:** You must hook the springs according to the images above. 

5

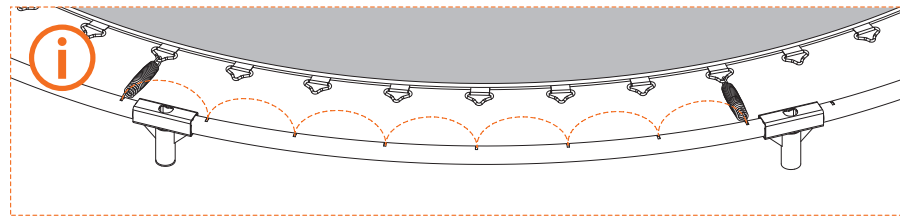
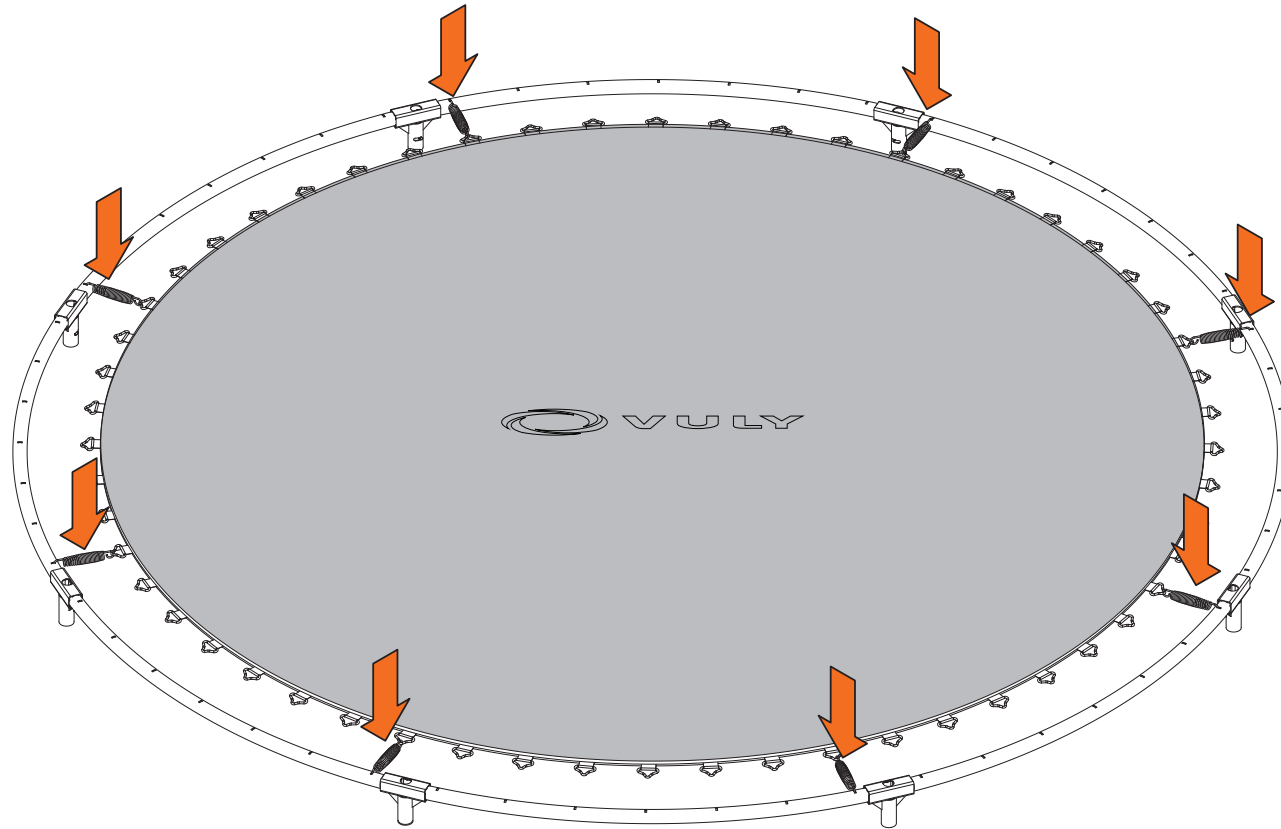

NOTE: Secure the Jump Mat using the Springs in a clockwise pattern. There should be one Spring every seven D-Shackles, as seen in diagram.



6

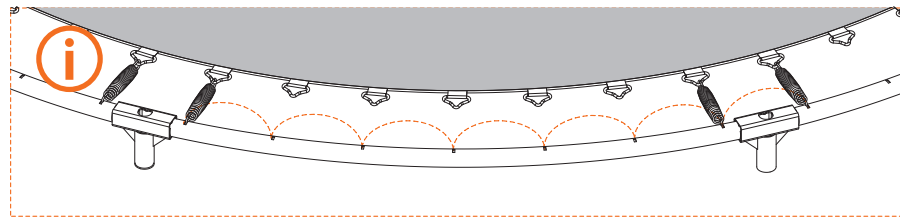
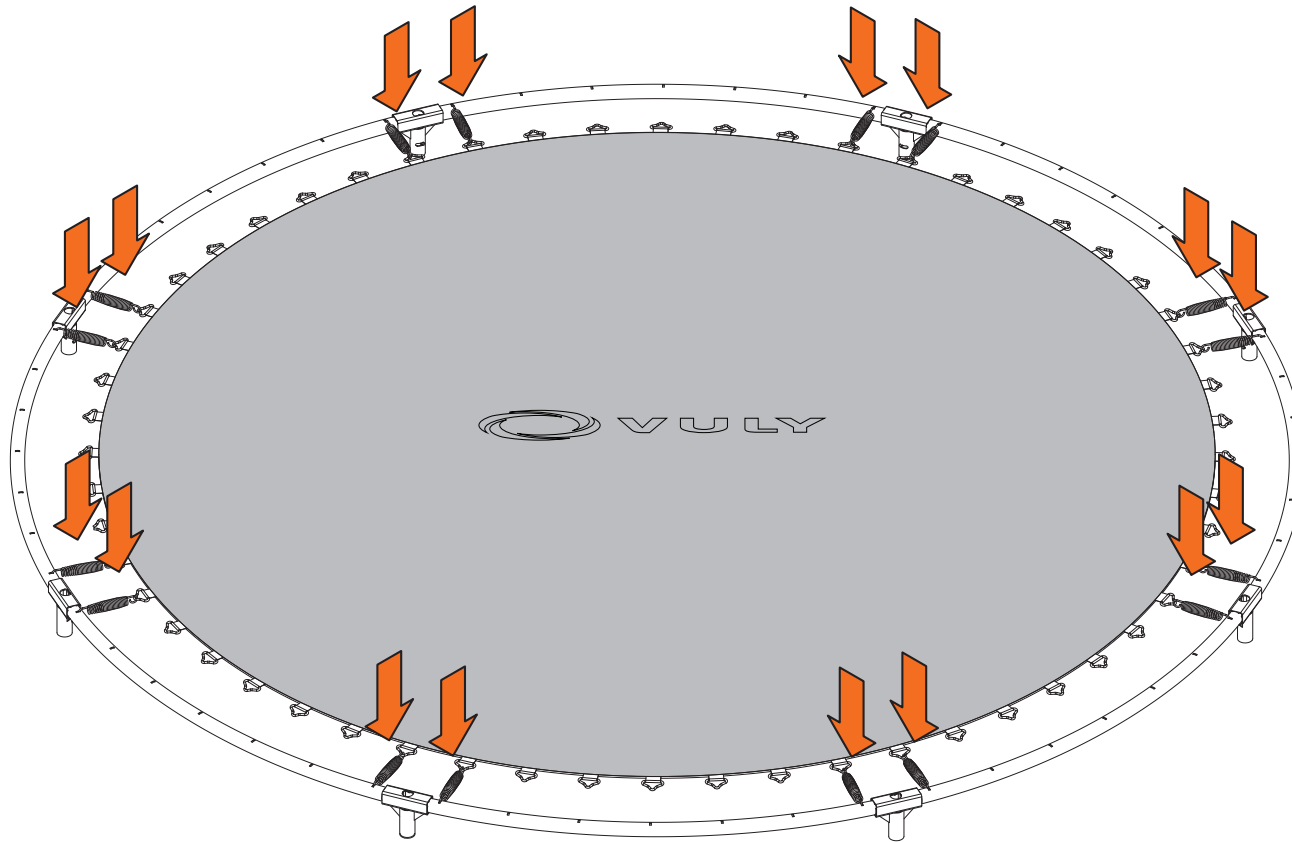

NOTE: Add a Spring to both sides of each Joiner.



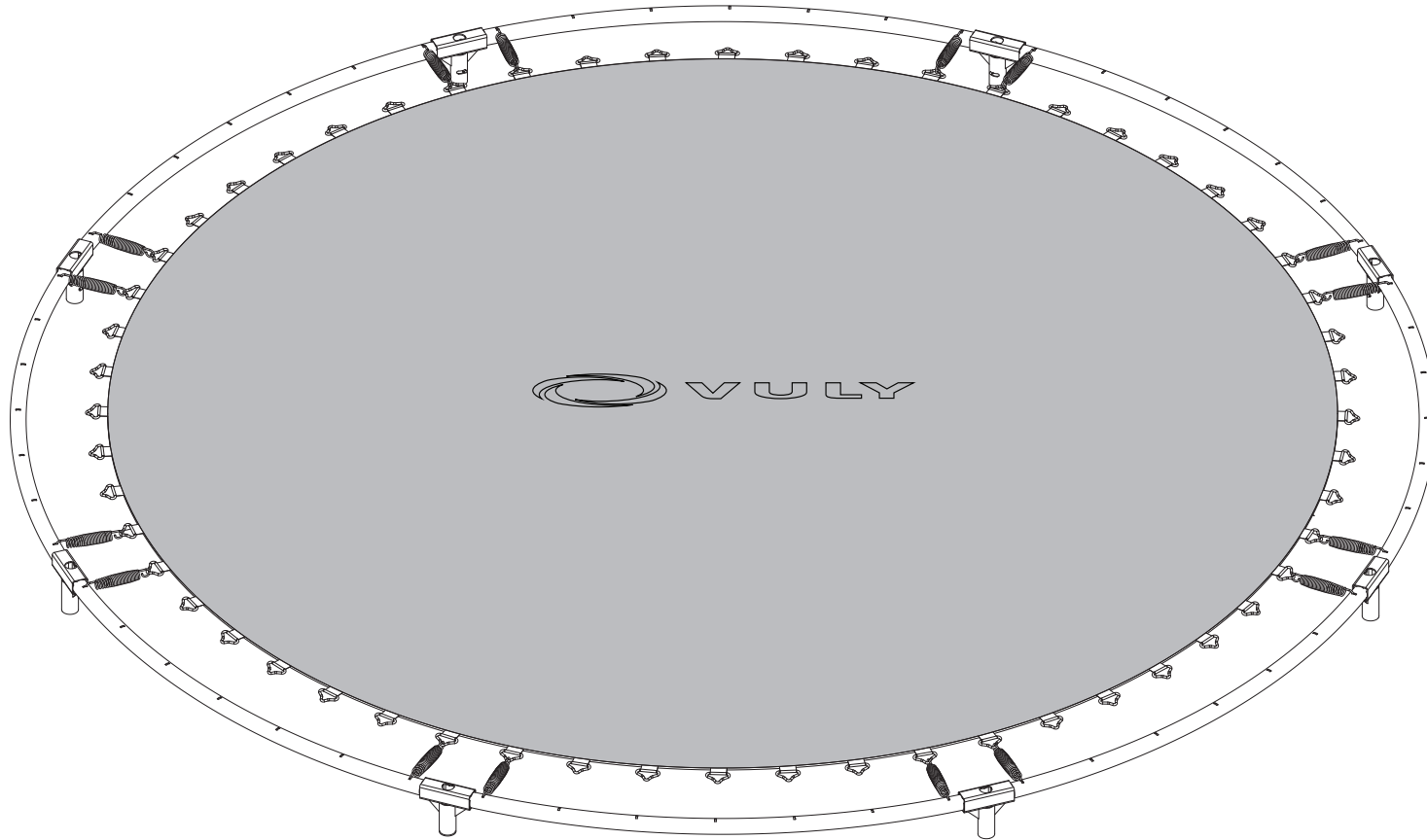

7

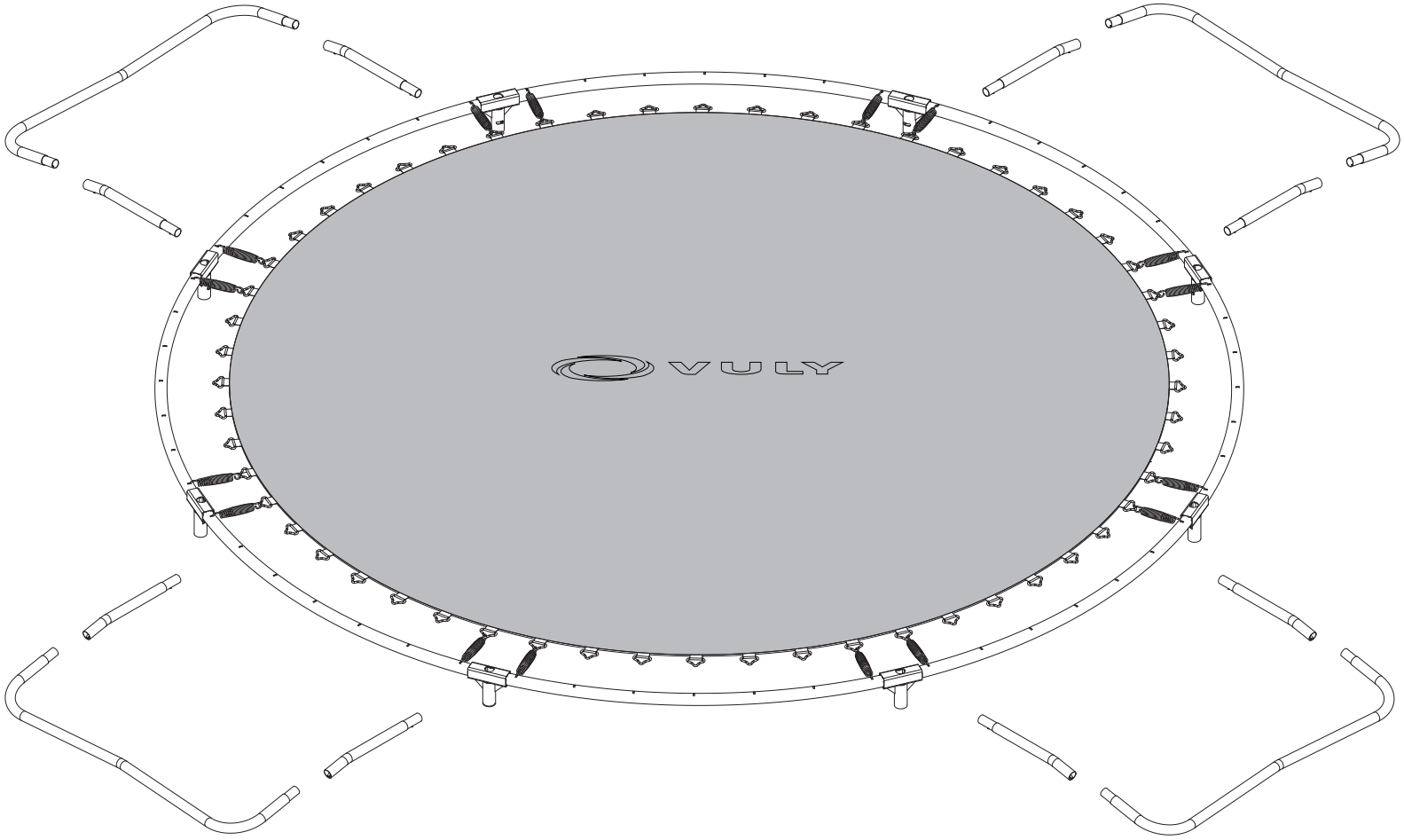
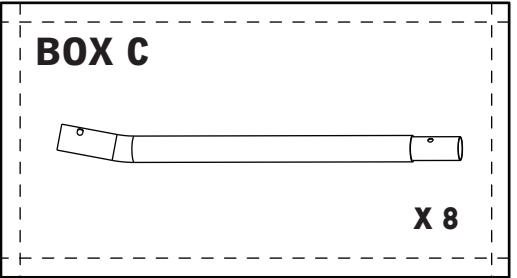
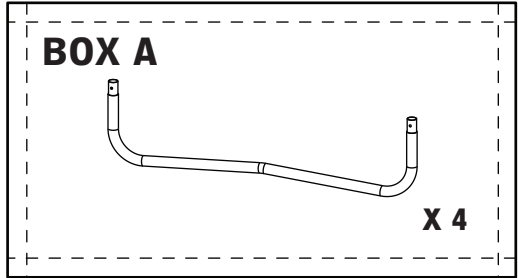

8

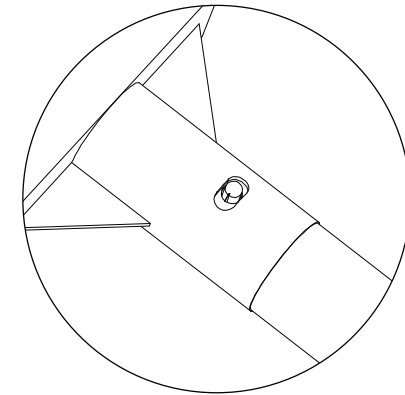
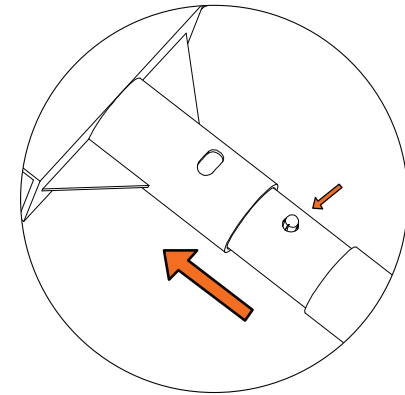

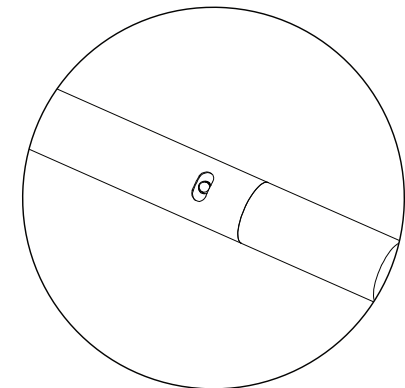
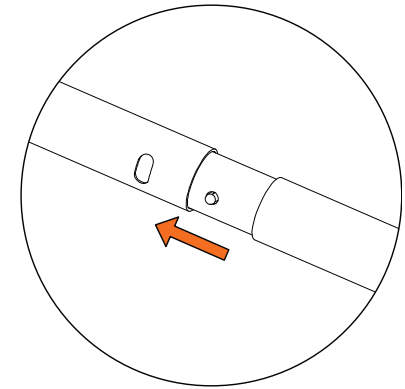
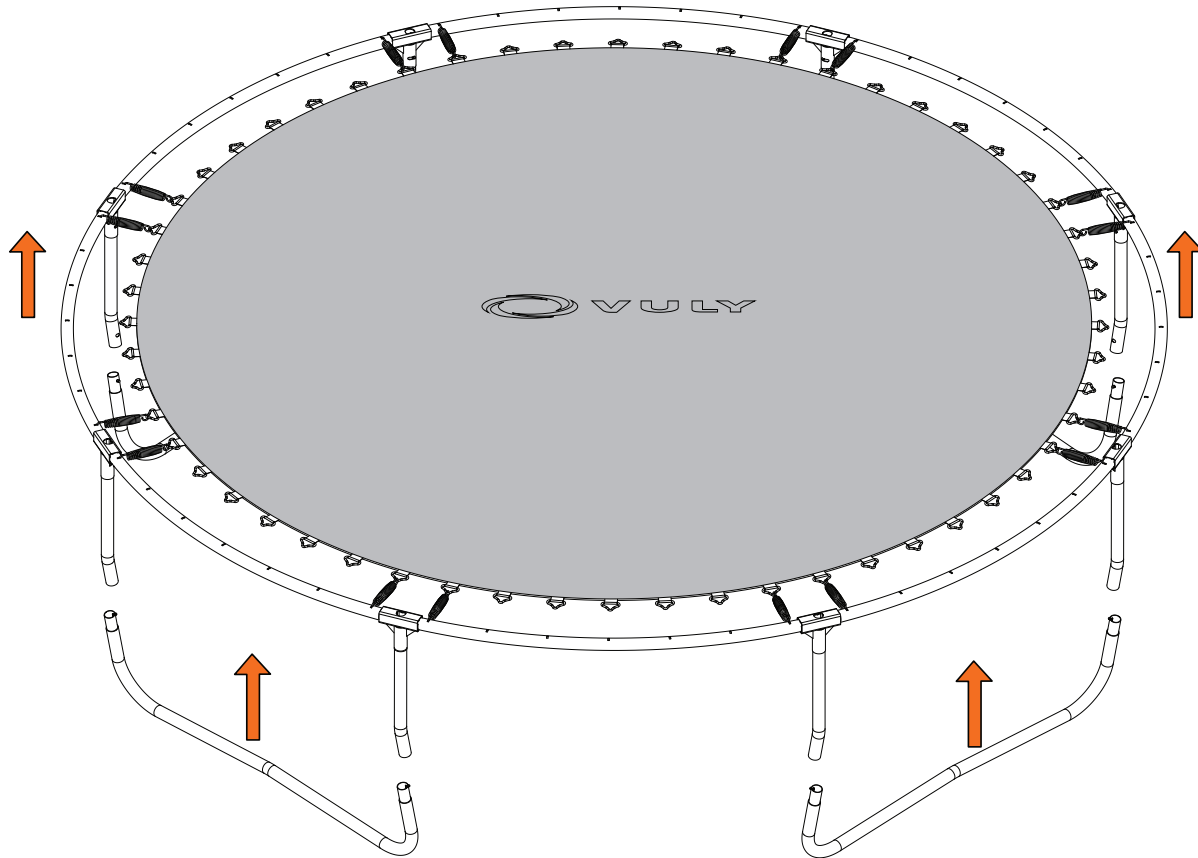

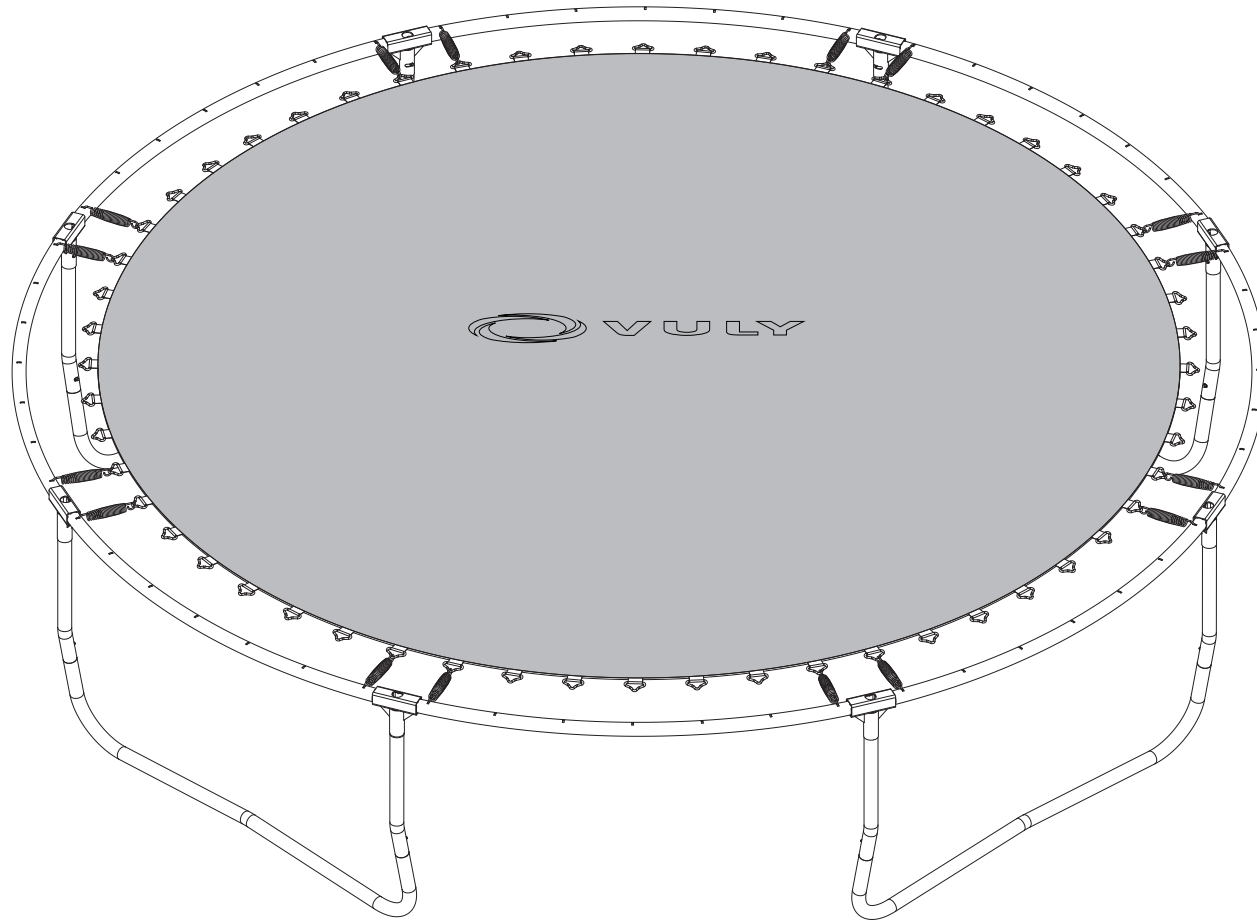

10

BOX A

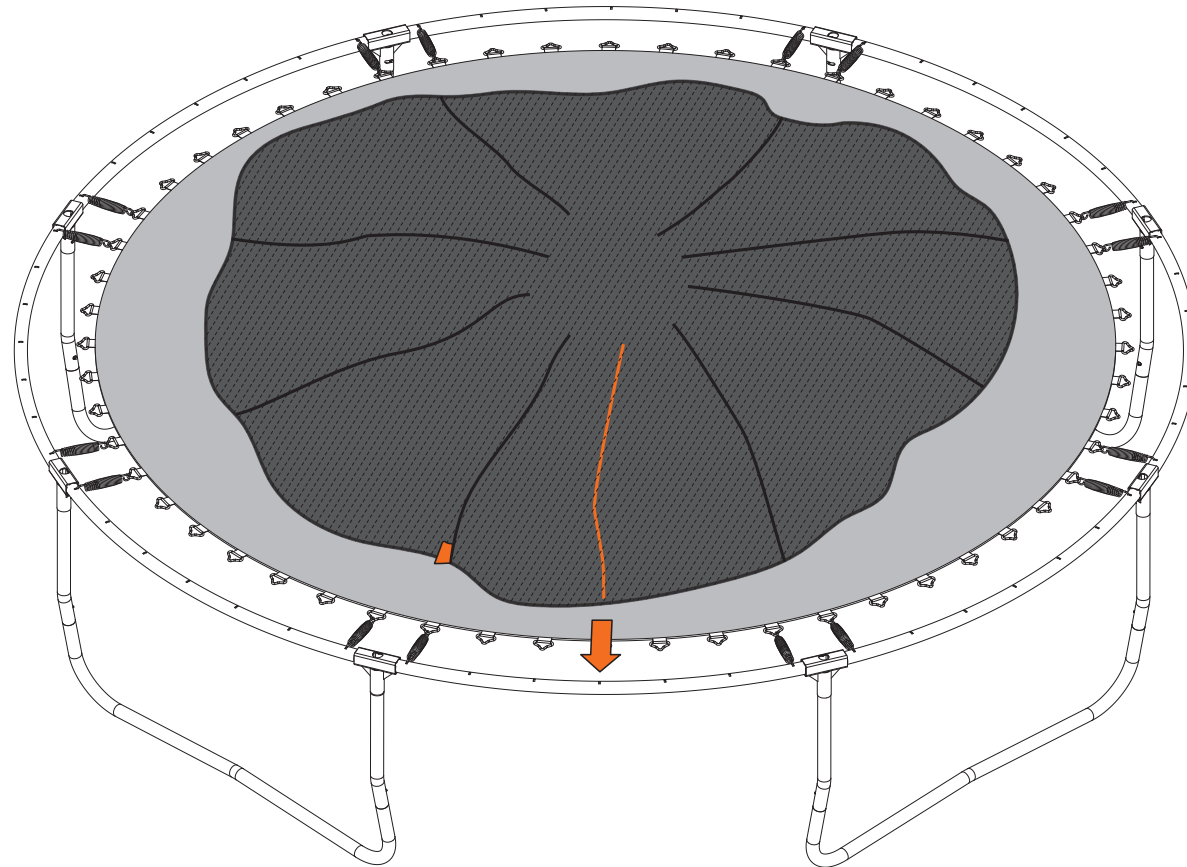

NOTE: Align tags from Safety Net to the Joiner.



11

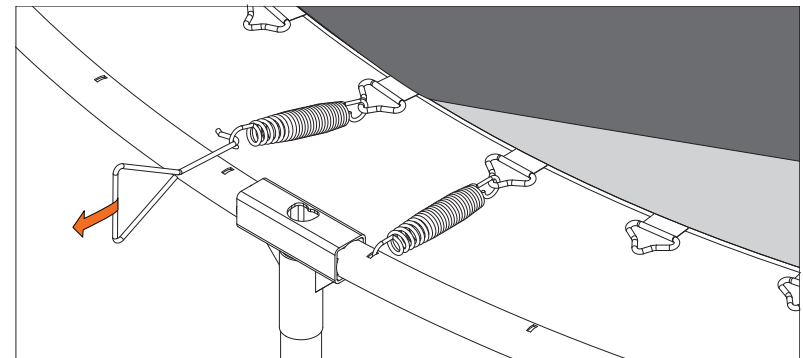
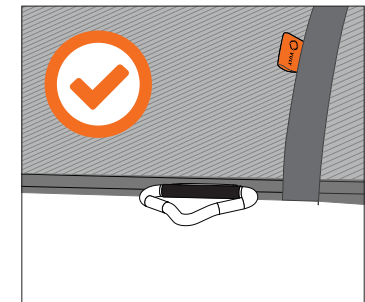
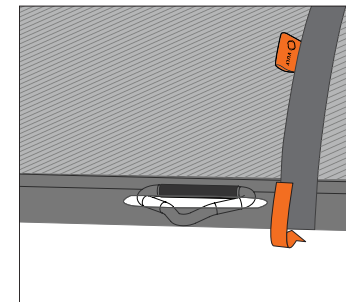
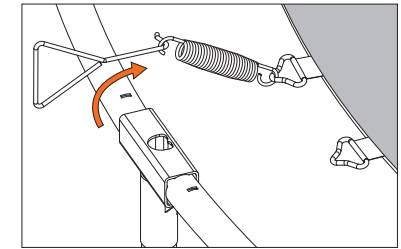
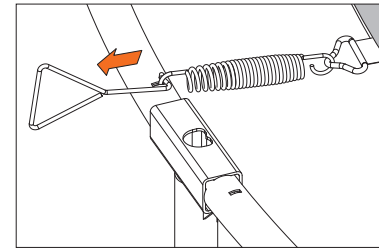
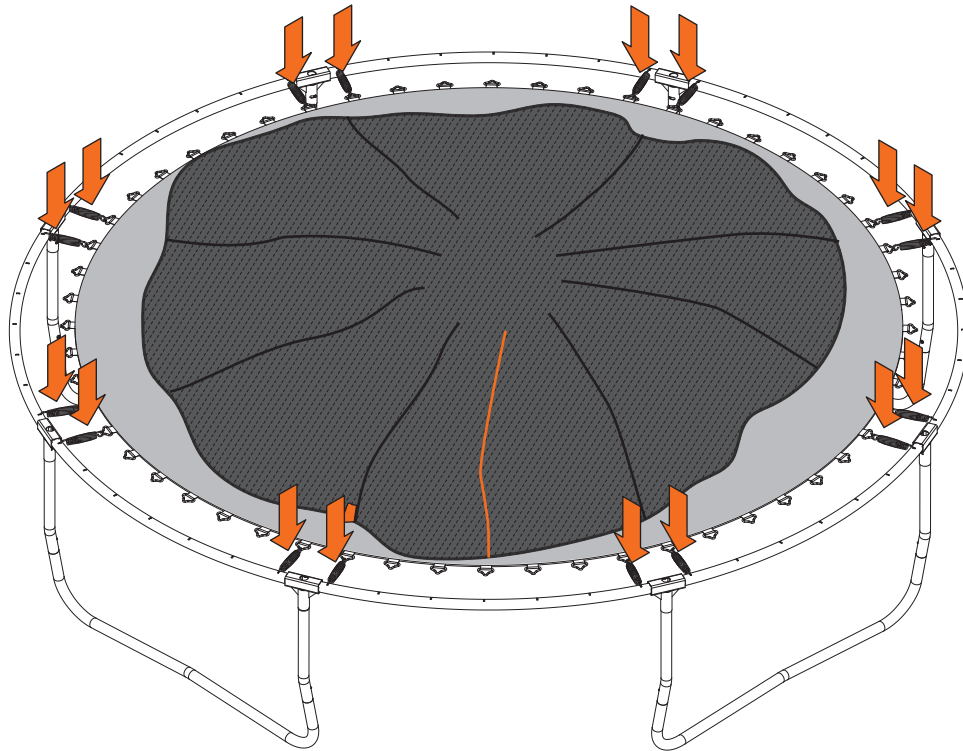

NOTE: Remove the Springs to attach the D-Shackles through the eyelets of the Safety Net. Repeat for both Springs then reattach them to the Frame.



12

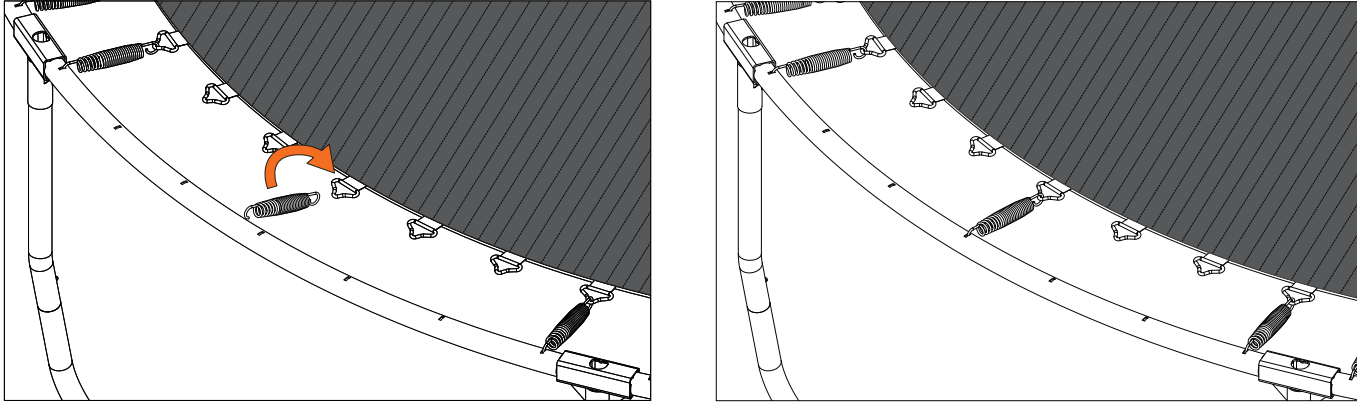

NOTE: Go around the trampoline and connect Safety Net to D-Shackles, then attach the remaining springs.

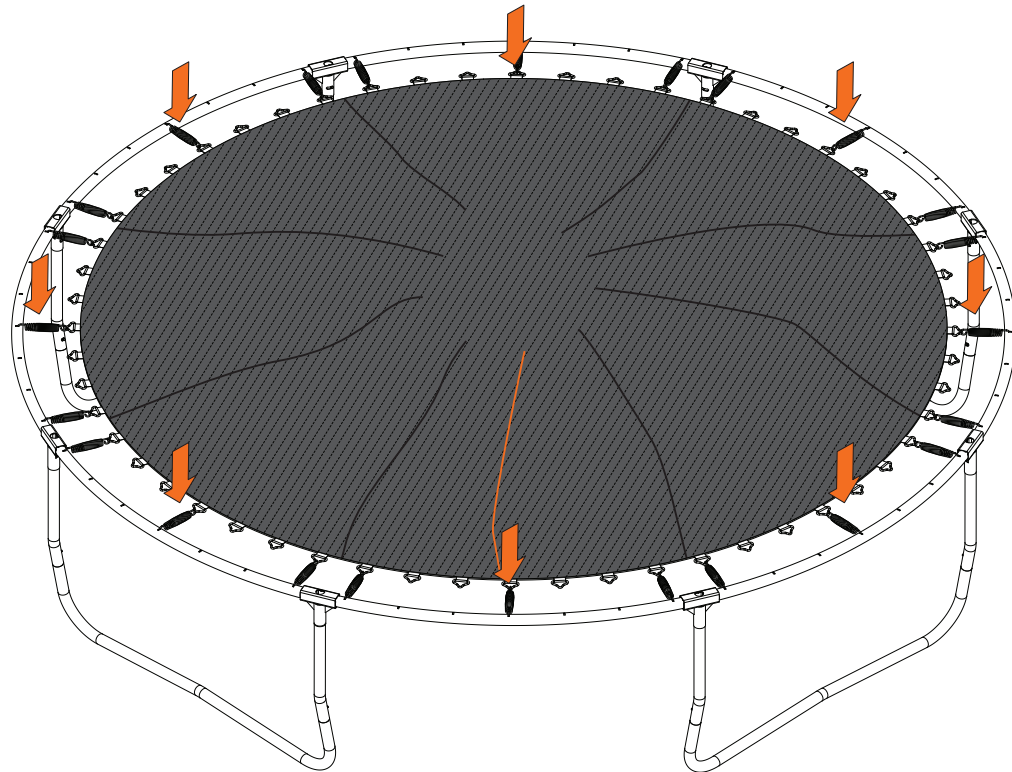

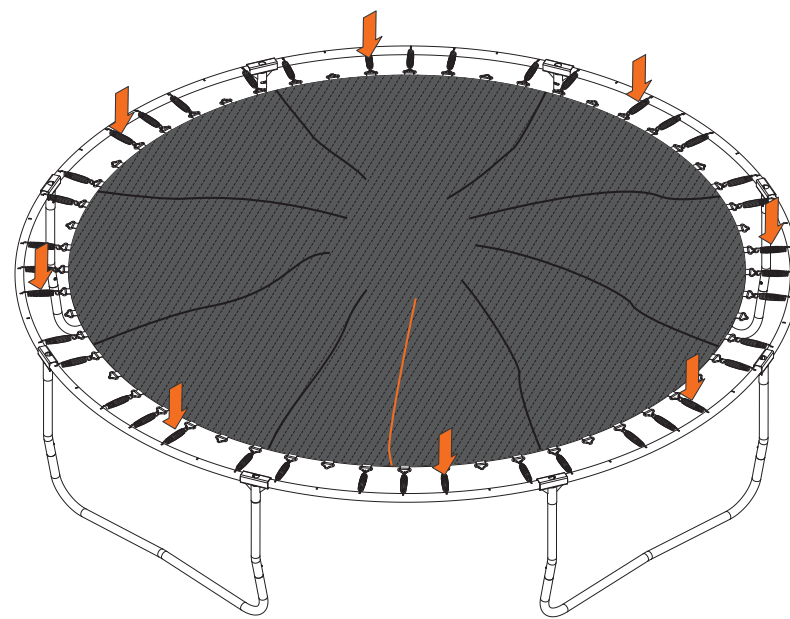
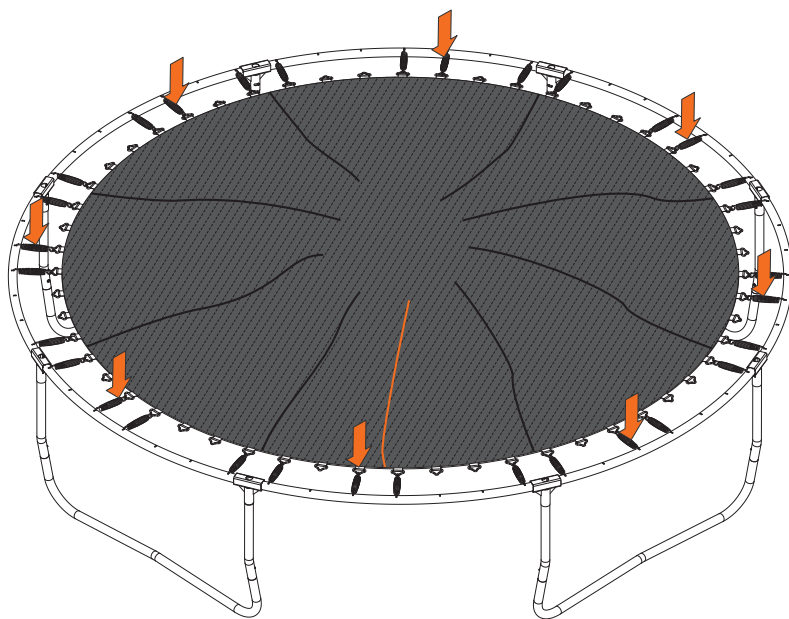
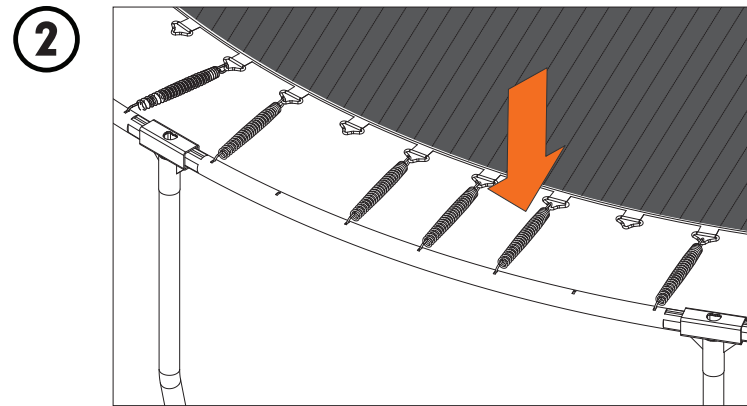
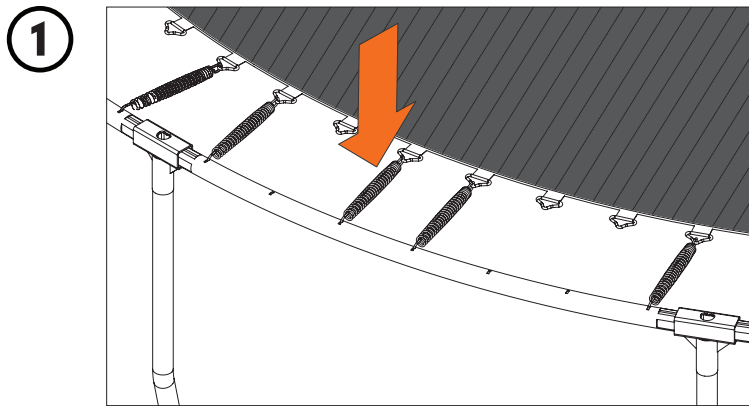

NOTE: ATTACH ONE SPRING PER SECTION AND PROCEED TO THE NEXT ONE.



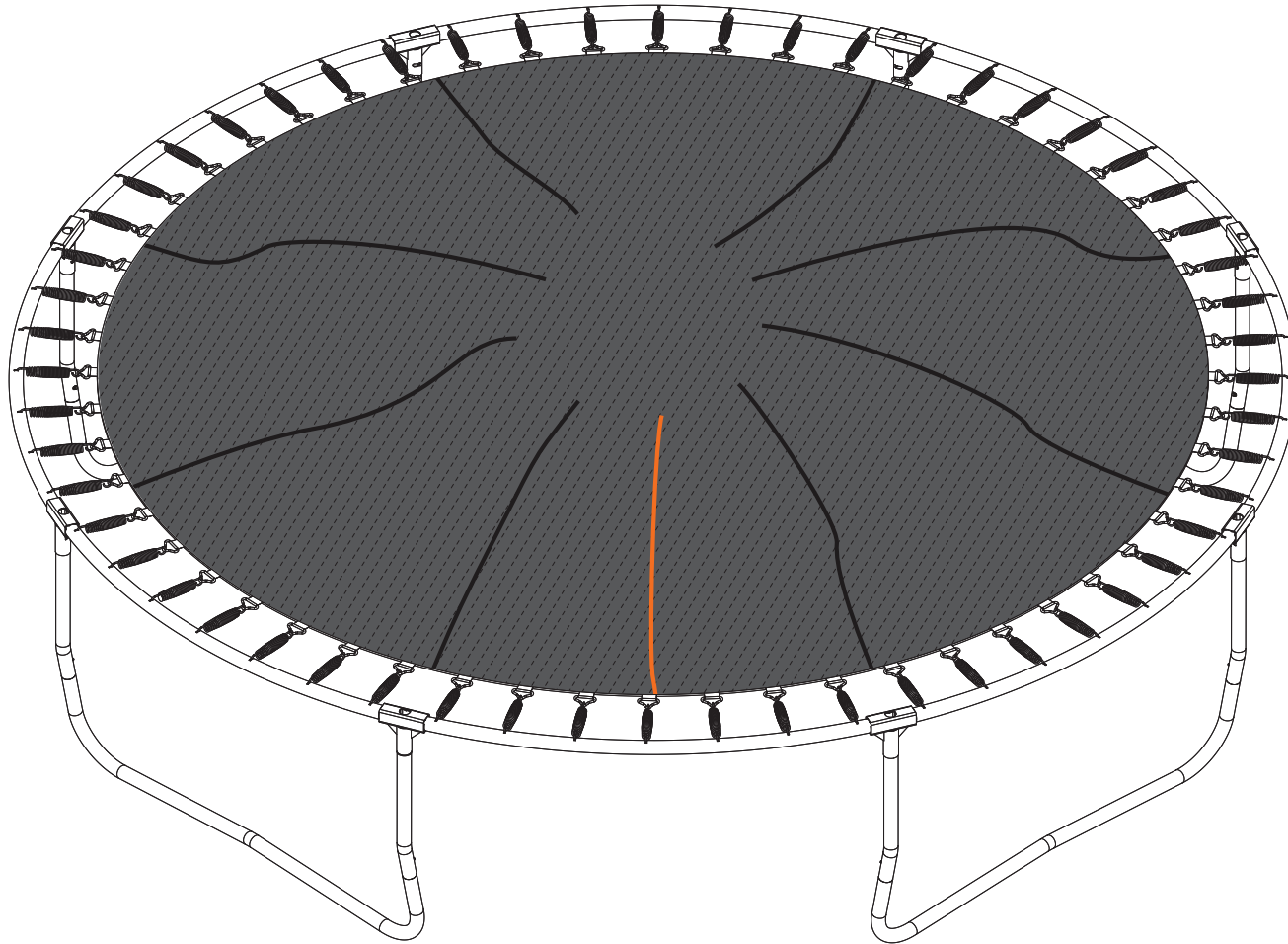

NOTE: Go around the trampoline and attach the remaining springs.



13

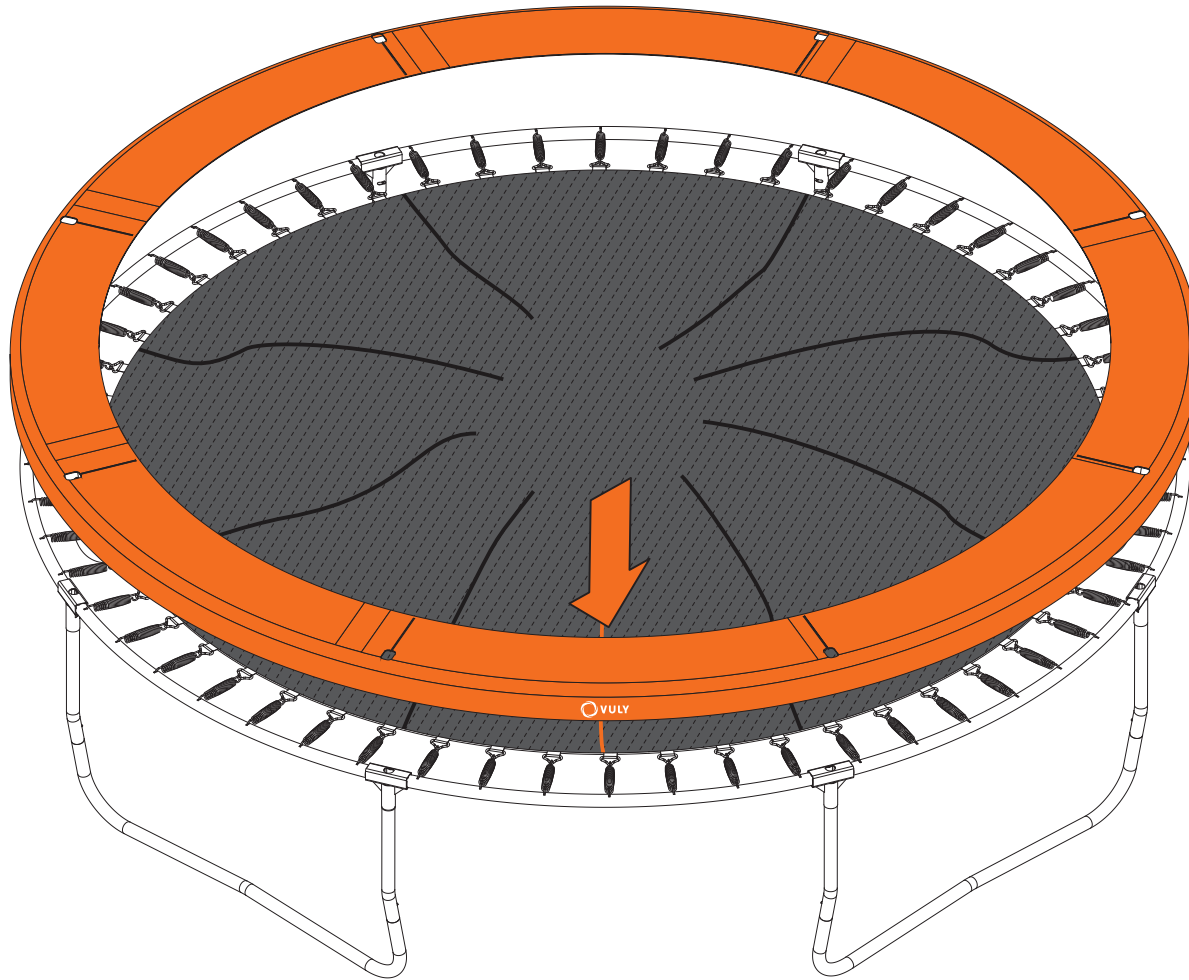
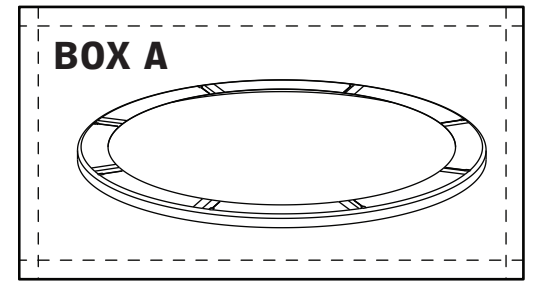

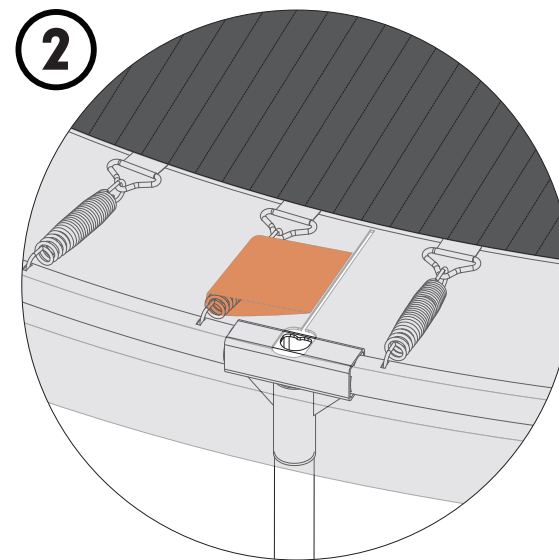
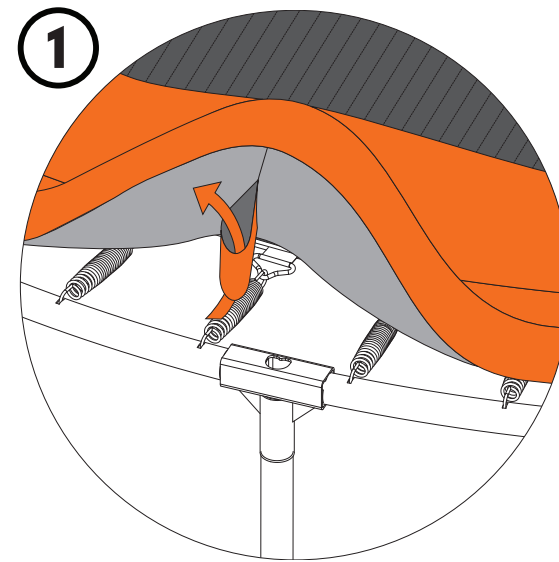
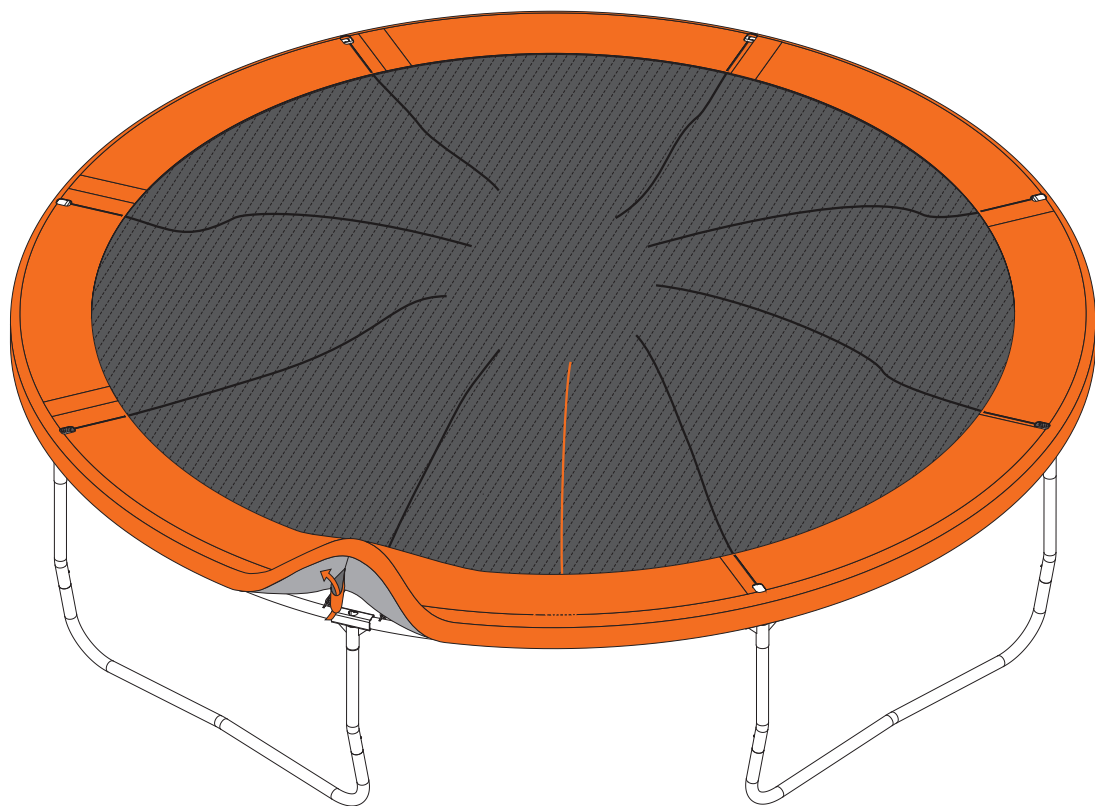

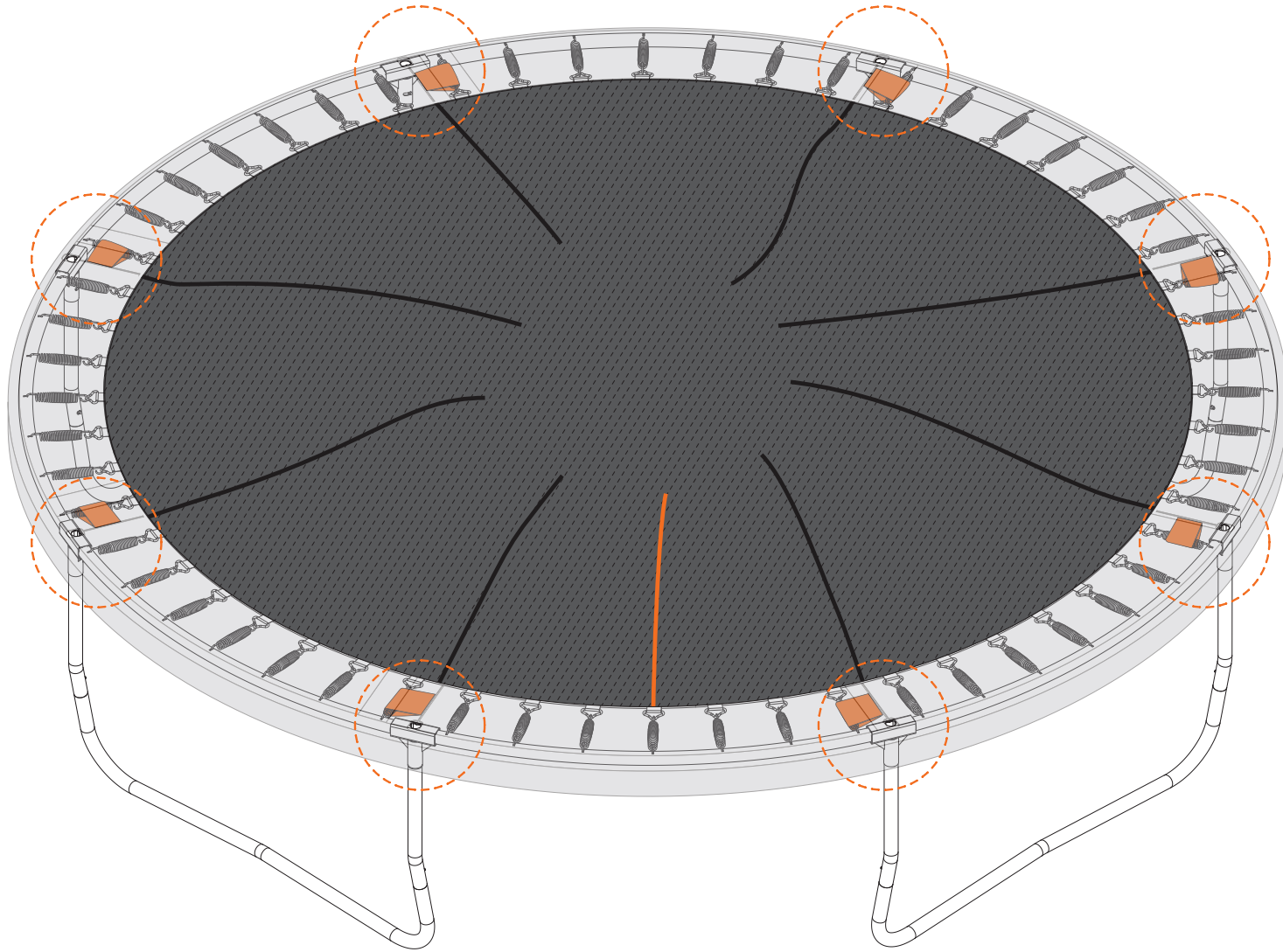

15

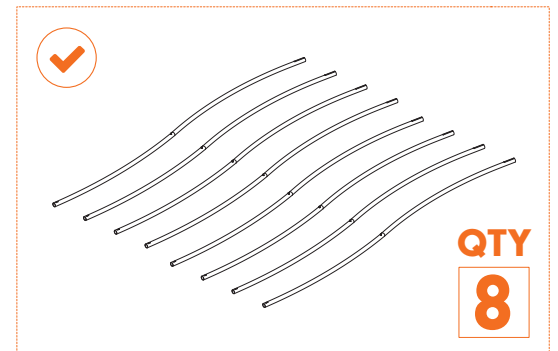
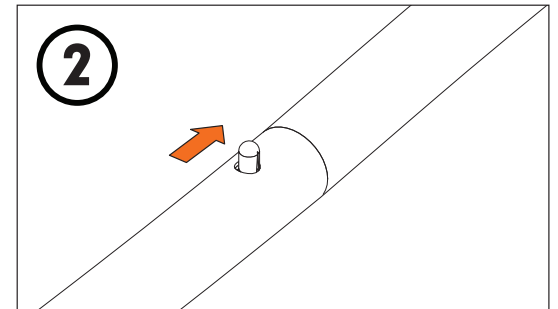
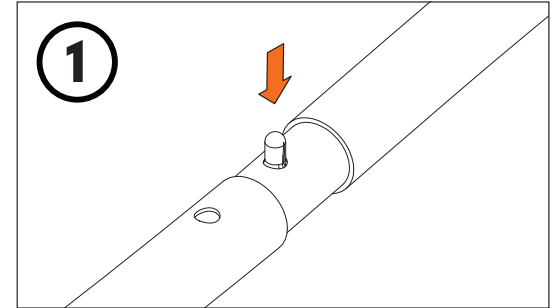
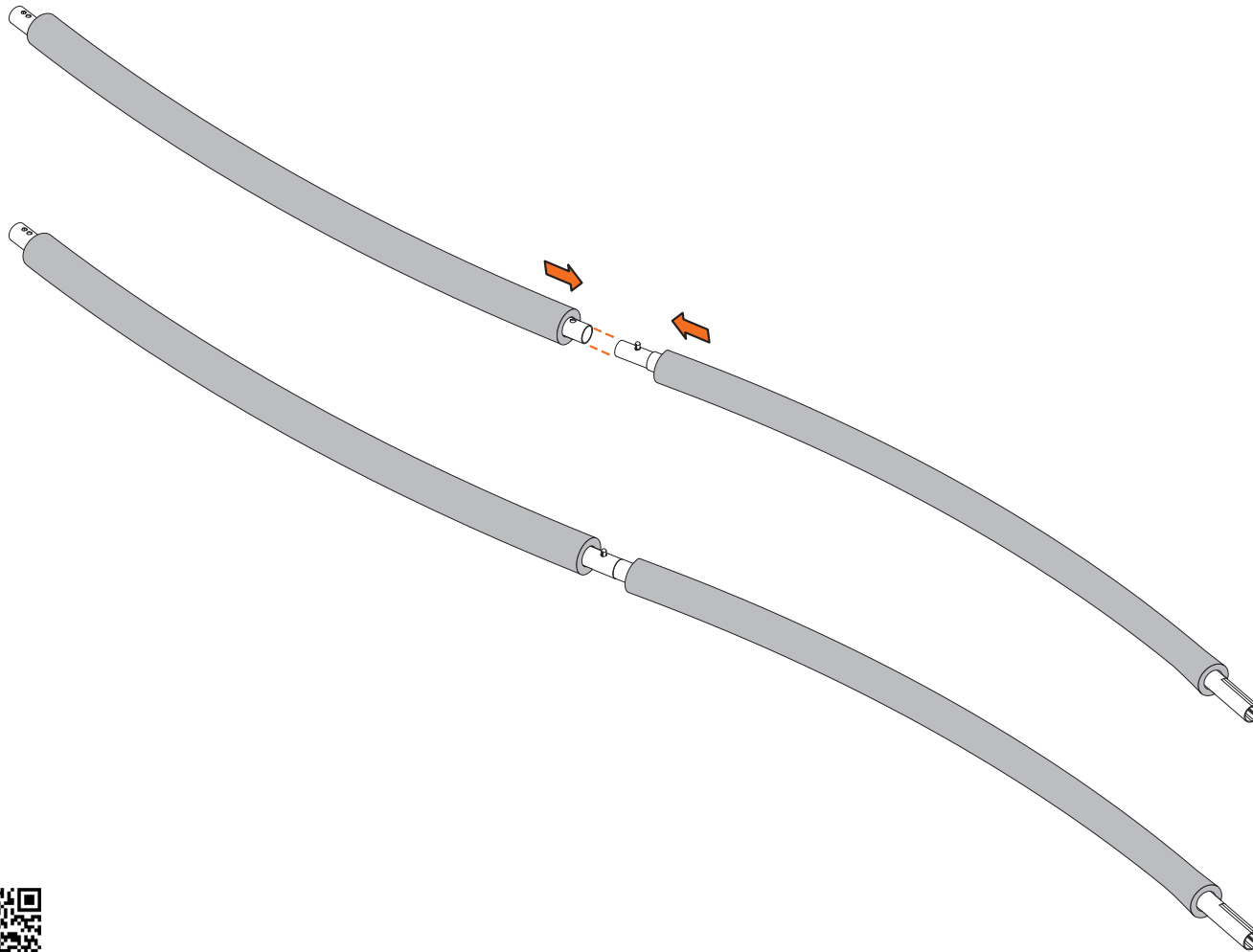
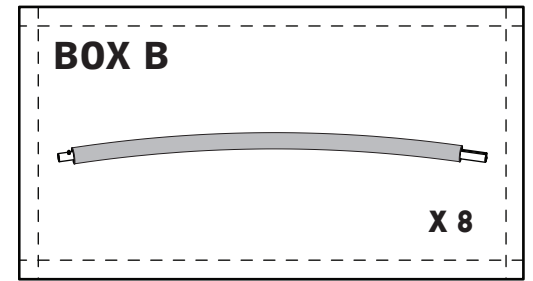
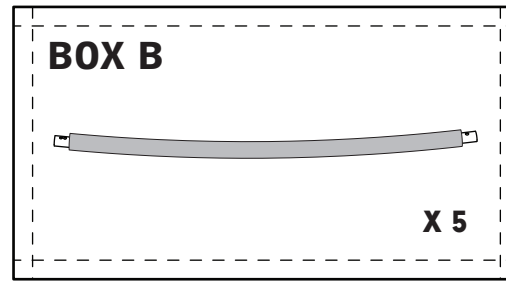
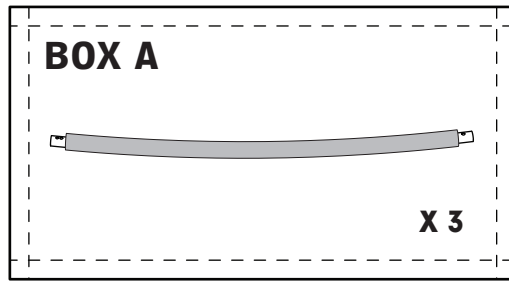

16

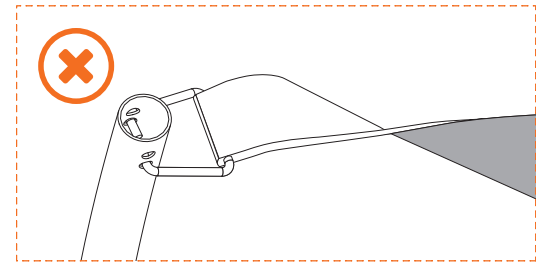
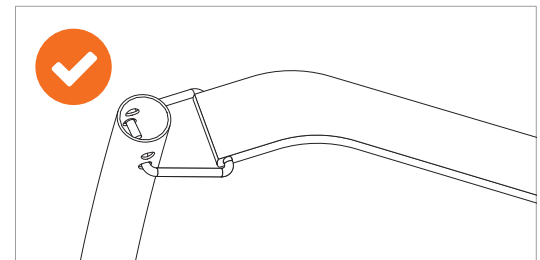
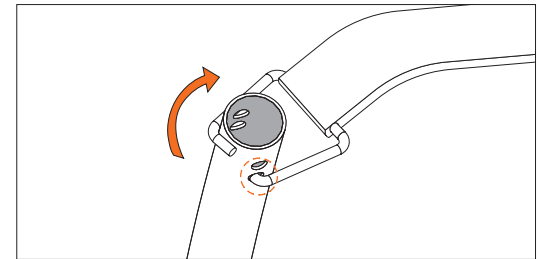
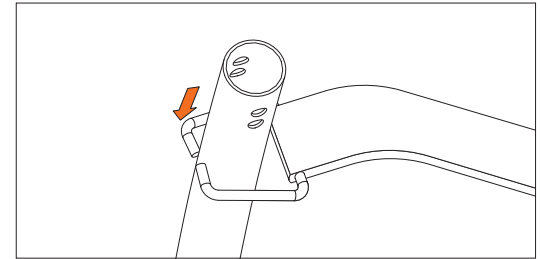
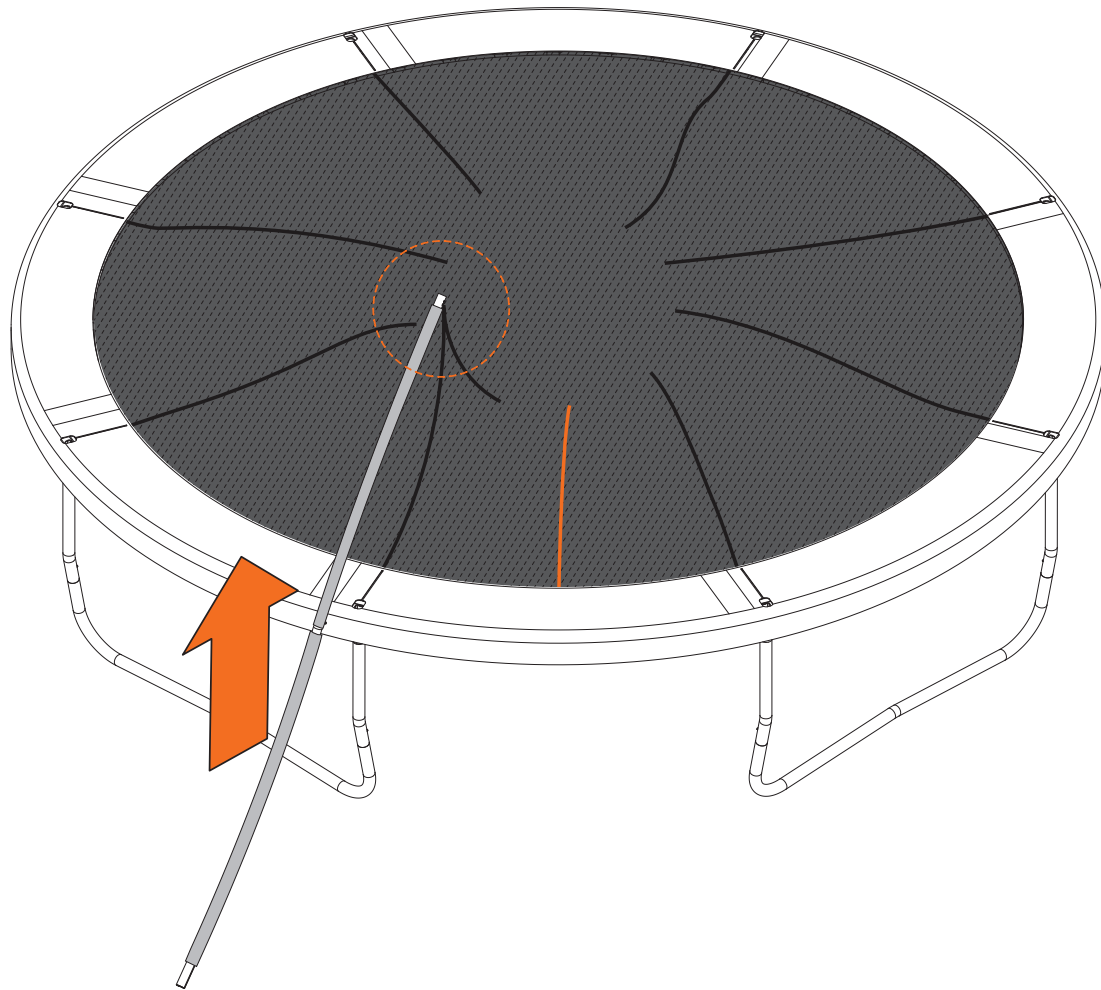

NOTE: Ensure the U-shaped hook is attached to the lower hole at the top of Upper Net Pole..



17

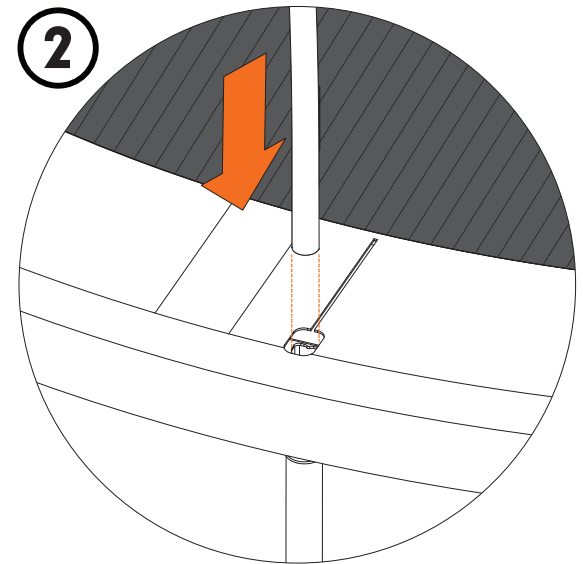
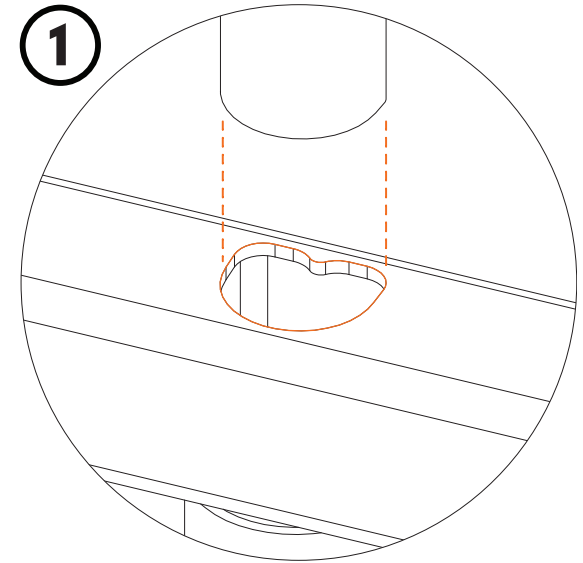
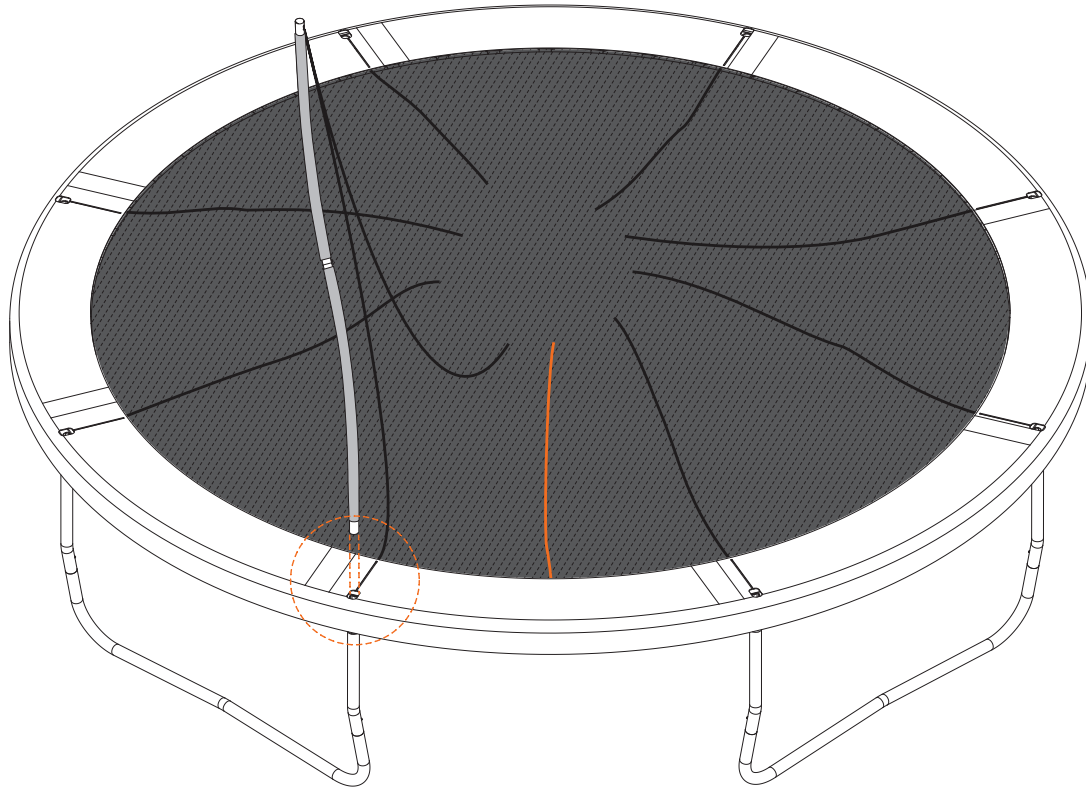

TIP: You may have to pull the net pole back toward yourself while pushing down to fully insert the net pole.



18

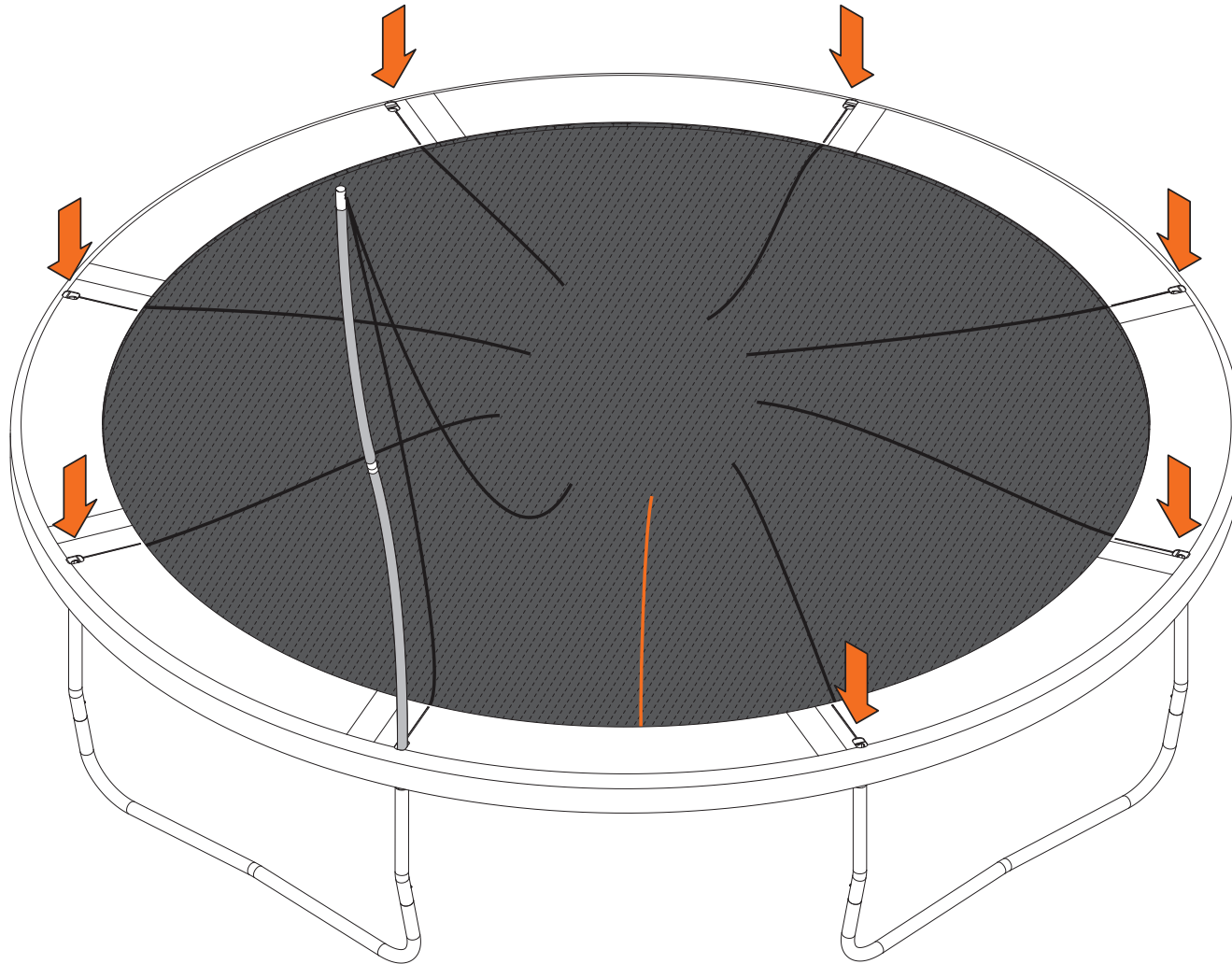

NOTE: Repeat Step 16 - 17 for all sides.



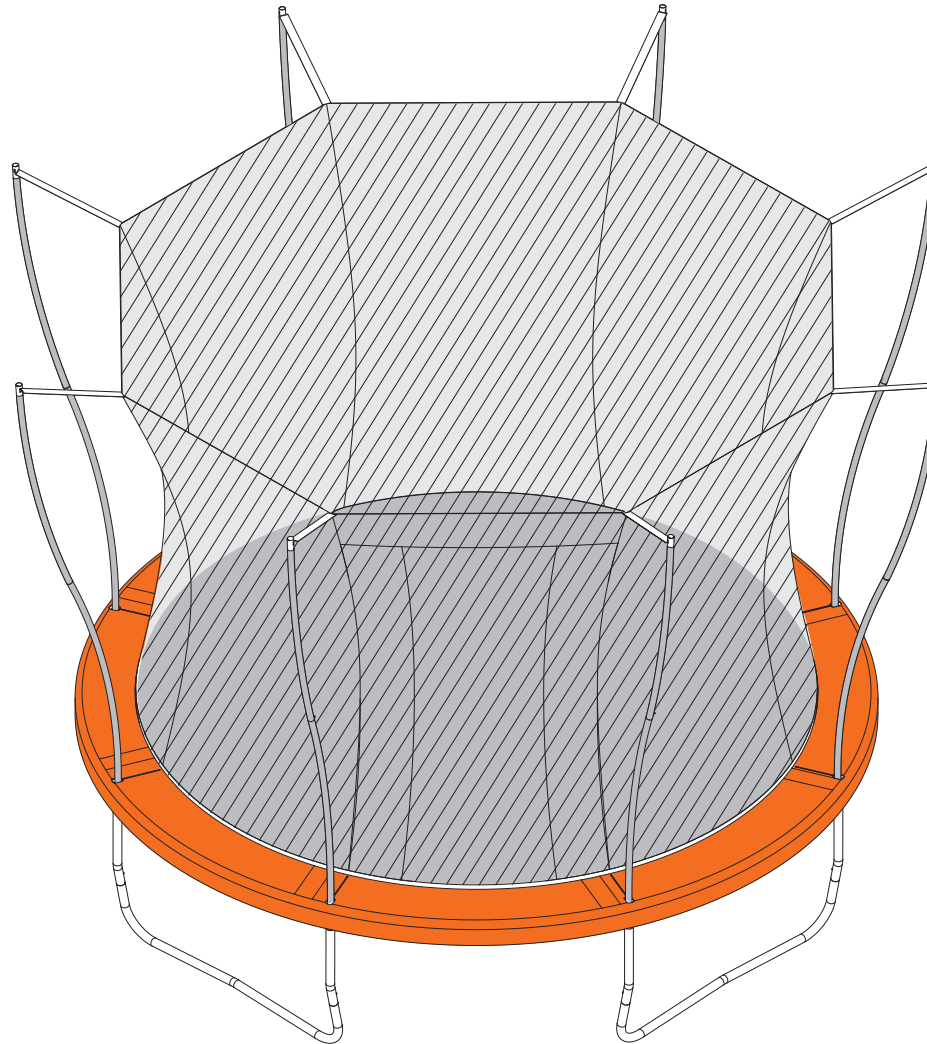

CONGRATULATIONS!

You have assembled your Flare trampoline.

5.0. Product registration

To access the Half-Price Parts for Life programme or to lodge a Warranty Claim, customers must ensure that their Vuly product is registered with Vuly.

Customers who purchase directly from Vuly (through VulyPlay.com, at the Vuly Showroom or over the phone) automatically have their product registered.

Customers who purchase through an Authorised Reseller must register their product by visiting **VulyPlay.com/Support** and completing the form with a proof of purchase.

6.0. Half-price replacement parts



Vuly offers half-price replacement parts to all customers for the lifetime of their trampoline purchase through the Half-Price Parts for Life programme.

This programme is subject to change at any time, and it is only available to customers who have purchased either through an Authorised Reseller or directly through Vuly.

Half-Price Parts for Life is only available to customers who wish to replace parts that are core components of their trampoline. For Flare, these parts include:

- Springs,
- Safety Padding,
- Jump Mat,
- Joiner Poles,
- Safety Net (and components thereof),
- Net Poles,
- Frame Tubes,
- T-Joiners.

The programme does not extend to accessories or to Shade Cover / Tent components.

7.0. Warranty

All Vuly products are sold with a manufacturing warranty, which assures that the item is free of defects in workmanship and materials ("warranty").

7.1. Warranty periods

Warranty periods do not reset for any reason, unless the customer purchases a new product. In this case, that particular item will be covered by its own warranty period. It does not affect - nor will it increase - warranty periods for other purchased items.

Warranty periods always commence from the date of item delivery, is for use under normal conditions and applies for:

Flare

- 36 months [3 years] to the Frame Poles, T-Joiners, Springs and Jump Mat (excluding the print).
- 12 months [1 year] to all other parts of a purchased trampoline - e.g. Safety Padding, Safety Net and Net Poles.

Accessories

- 12 months [1 year] to purchased accessories - e.g. Mister, Deck - not received during a promotional period.
- 3 months to any items received at no cost as part of a promotion - e.g. 'Free Shade Cover'.

The customer may extend the standard 12-month [1 year] warranty to 36 months [3 years], if they purchase an extended warranty within 7 days of their delivery date.

7.2. Inclusions

This warranty covers manufacturing faults and defects only.

If a product is damaged or rendered unsafe as a result of a departure from its design specifications during production, this constitutes a manufacturing fault or defect.

This may occur if - for example - use of incorrect textiles during manufacturing causes a Safety Net to disintegrate, or if improper welding produces an unstable Frame.

7.3. Exclusions

7.3.1. Damage through wear and tear

This warranty does not extend to normal wear and tear of the product. This may include, but is not limited to:

- Rusting of steel components,
- UV deterioration of textile components,
- Stretching of springs.

As outdoor products that are actively used, trampolines and their accessories will experience wear and tear over time.

7.3.2. Damage through weather conditions

Damage to the product that results from weather events – such as rain or wind – are not covered under the warranty. Vuly suggests that you contact your home and contents insurer if your trampoline is damaged by such events.

7.3.3. Damage through improper installation

This warranty does not extend to any failure of the product caused by installation not in accordance with the Vuly Manual. Customers must assemble their Vuly product by following carefully the Installation section of their Vuly Manual.

Furthermore, the warranty does not cover installation provided by a third-party assembly service. It is the customer's responsibility to check all boxes and confirm that all components are included in the correct condition before installing.

7.3.4. Damage through insufficient care or maintenance

This warranty does not extend to accelerated decay of the product caused by poor care or maintenance. It is essential that customers regularly check, and follow the advice of, the Care and Maintenance section of their Vuly Manual to ensure that their product lasts as long as possible.

7.3.5. Damage through inappropriate use

This warranty will be void if the product is used for any other activity besides those for which it was intended. Vuly products constitute recreational trampolines and accessories for such trampolines. They are not intended for use as professional, gymnastics trampolines, springboards, etc.

Any evidence that inappropriate actions have led to product failure will not be covered by the warranty. Similarly, replacement parts or repairs needed to mend such damage will not be covered under the warranty.

7.3.6. Damage through salt water proximity

This warranty (on steel components, specifically) will be reduced by 50% where the Vuly product is assembled within 1.6 km of a salt water environment or where it is subject to ocean spray.

7.3.7. Personal Injury

The warranty does not cover personal injury or losses due to any of the above: wear and tear, weather conditions, inappropriate installation, insufficient care or maintenance or inappropriate use, nor does it cover damage due to negligence or accidents.

7.4. Warranty Claims

If a customer believes that a Vuly product is faulty or defective, they must discontinue use and submit a Warranty Claim. A customer must not attempt to use a product if any part is faulty or defective, as it may be dangerous. Any damage that the user causes as a result of using faulty or defective products will lead to voiding of the warranty.

7.4.1. Making a Warranty Claim

To fulfil a warranty claim, a customer must submit an online Warranty Claim at **VulyPlay.com/Support**.

Submitting the online Warranty Claim form requires the customer to provide:

- Details of their purchase – including date,
- Batch number,
- Clear photographic evidence of the manufacturing fault or defect.

If the customer does not provide all details that the form requires, their Warranty Claim will not be assessed.

Vuly may take up to 7 days to process Warranty Claims upon a completed submission. It may take a further 7 days for replacement parts to reach the customer.

7.4.2. Successful Warranty Claims

If Vuly accepts a customer's Warranty Claim, Vuly will replace the faulty or defective parts, not offer refunds.

Successful Warranty Claims lodged within 60 days of the delivery date:

Vuly will replace the damaged parts free of charge. Vuly will also cover any costs associated with shipping the replacement part.

7.4.3. Walk-in Warranty Claims

If a customer wishes to make a Warranty Claim while on the Vuly premises, they must first submit an online Warranty Claim at **VulyPlay.com/Support** – providing all required details.

7.4.4. Refunds

In all instances of successful warranty claims, Vuly offers replacements parts only. Vuly provides refunds only at their discretion. Any refunds granted to the customer exclude third-party fees, such as assembly services and credit card surcharges.

7.4.5 Claiming on non-Vuly products

Products sold alongside Vuly that are not Vuly-branded are subject to the warranties provided by the companies that supply them. The customer must contact these external companies to make a warranty claim; Vuly will not assess claims made against non-Vuly products.

7.5. Australian Consumer Law

Our Goods come with guarantees that cannot be excluded under the Australian Consumer Law. You are entitled to a replacement or refund for a major failure and for compensation for any other reasonably foreseeable loss or damage. You are also entitled to have the Goods repaired or replaced if the Goods fail to be of acceptable quality and the failure does not amount to a major failure.

8.0. Missing parts

If a customer believes that a Vuly product does not include all necessary parts, they must immediately lodge a Missing Parts Claim at **[VulyPlay.com/Support](https://www.vulyplay.com/support)**.

A customer must not attempt to use a product if any part is incomplete, as it may be dangerous. Any damage that the user causes as a result of using incomplete products will lead to voiding of the warranty.

Vuly trampolines are delivered to Vuly warehouses prepackaged; we are unable to check the boxes prior to delivery to ensure that they contain all the required parts. While the missing part rate during packing is very low, some parts may also fall out in transit due to small, unintentional tears in their boxes.



See [VulyPlay.com/Terms](https://www.vulyplay.com/terms) for the most recent Vuly warranty policies, terms and conditions.