



Quest™

---

# MANUAL XL

---



## ATTENTION!

SAFETY INFORMATION, INSTALLATION AND USAGE INSTRUCTIONS.  
READ PRIOR TO INSTALLING AND USAGE.

See [VulyPlay.com/support](https://www.vulyplay.com/support) for any updates to these instructions.



Visit [www.vulyplay.com/install](https://www.vulyplay.com/install)  
for step by step video instructions, or scan this QR code

If you have any feedback regarding our instructions, feel free to  
email [instructions@vulyplay.com](mailto:instructions@vulyplay.com) so that we can continue to improve.

# Contents

Read and follow all instructions in this manual before using your system, and do not use it in any way that is not described in this manual.

Responsibility rests with the owner and supervisors of the product to make sure that all users are aware of the practices specified in this manual.

1.0. Care and Maintenance .....	4
1.1. General care .....	4
1.2. Rust and corrosion .....	4
1.3. Textile deterioration .....	4
1.4. Weather care .....	4
2.0. Usage and Behaviour .....	5
2.1. Safe use information .....	5
2.2. Safe use instructions .....	5
3.0. Pre-assembly .....	6
3.1. Size Reference .....	6
3.2. Tips & Tricks .....	7
3.3. Parts and components .....	8
4.0. Assembly instructions – Vuly Quest .....	13
5.0. Product registration .....	56
6.0. Half-price replacement parts .....	56
7.0. Warranty .....	56
7.1. Warranty periods .....	56
7.2. Inclusions .....	56
7.3. Exclusions .....	56
7.4. Warranty Claims .....	57
7.5. Australian Consumer Law .....	57
8.0. Missing parts .....	57

## ATTENTION!

Safety information, installation and use instructions.

Read prior to installing and using the monkey bar system.

See **VulyPlay.com/support** for any updates to these instructions.

## YOU WILL NEED THESE FOR ASSEMBLY!

- Ladder
- Rubber mallet
- Tape measure or ruler

# DISCLAIMER

The following Conditions of Sale will apply to, and bind the purchaser of, any Vuly Trampolines Pty. Ltd. ABN: 91 160 793 706 product.

## NOTICE TO USER:

Please read this agreement carefully before purchase or assembly. By purchasing, opening and assembling this product you acknowledge that you have read this agreement, understand it and agree to be bound by its conditions. If you are making a purchase on behalf of another person, you agree that you are making the purchase as their agent.

## LEGAL RIGHTS – PLEASE READ:

EXCLUSION OF LIABILITY – WAIVER OF RIGHT TO SUE – YOUR ASSUMPTION OF RISK – THESE CONDITIONS AFFECT YOUR LEGAL RIGHTS.

Vuly Trampolines Pty. Ltd. ABN: 91 160 793 706 (“Vuly”), as supplier of trampolines and accessories (“Products”), sells all Products subject to the following conditions:

1. To the maximum extent permitted by the law, Vuly, its employees, directors and agents will not be liable to the customer, their dependents or legal representatives for damage to property, personal injury or death suffered by the customer because the Product was not manufactured or supplied with due care and skill, the Product is not reasonably fit for its purpose or because of negligence, breach of contract, breach of statute or breach of statutory duty by Vuly.
  2. Vuly, its employees, directors and agents are not liable to the customer, their dependents or legal representatives for personal injury or death suffered by the customer because the Product was not:
    - a. installed in accordance with the Vuly instruction manual. It is the customer’s responsibility to check all boxes to confirm that all components are included and in the correct condition before assembly.
    - b. installed with due care and skill, by a the customer or a third party assembly service; and
    - c. in the same condition as when the Product was supplied, due to wear and tear – including, but not limited to, weather damage, deterioration of the net, spring stretch, UV deterioration or rust.
  3. The customer acknowledges that using the Product can be dangerous, with inherent risks and hazards. As a consequence, personal injury or death may occur. The customer assumes and accepts all such risks, and hereby – to the full extent permitted by law – waives the right of action against, and fully releases Vuly for, loss, damages, personal injury or death in any way caused by, or relating to, the customer’s participation in such activities.
- This includes – without limitation – liability for any negligent or tortuous acts or omission, breach of duty, breach of contract or breach of statutory duty on the part of Vuly, its office bearers, directors, employees or agents.



## WARNING:

To reduce the risk of injury while using the system, enforce the following:

- Minimum user age – 6 years.
- Maximum number of users – 6.
- Adult assembly required.
- Adult supervision required at all times.
- Ensure that the system is secured with anchors or bolts before use.
- Exercise caution at heights. Maximum fall height is 1 m.



## WARNING!

Strong winds and wild weather can cause products to lift up and move, to avoid danger please secure your product.

---

## Vuly Play

95 Ingleston Rd, Wakerley QLD 4154  
www.vulyplay.com

AU: 1300 667 514  
US: 1-833-333-8888

# 1.0. Care and Maintenance

Improper maintenance or lack of care can lead to your system deteriorating earlier than expected and causing injury. Please follow these instructions to ensure that your product lasts for as long as possible.

## 1.1. General care

- Retain this Manual.
- Inspect before and after each use.
- Replace any worn, deteriorated, defective or missing parts immediately and only through Vuly.
- Tighten all hardware, including elements that secure the system to the ground.
- Keep away objects that could damage textile components.
- Ensure that moving steel components remain well lubricated.
- Use only parts and accessories recommended by Vuly.

## 1.2. Rust and corrosion

- Be aware of, and check, areas that are particularly prone to rusting:
  - Places where water is easily trapped.
  - Hollow sections of steel (which can appear in good condition on the outside, while hiding rust on the inside).
  - Sections where steel components join together.
- Inspect the inside of all tubes every 6 months – as well as after rain – and remove any water from the inside surfaces.
- Use general-purpose grease on steel connection areas.
- Avoid cleaning steel components excessively; it may reduce the effectiveness of their protective coatings.

## 1.3. Textile deterioration

- Remove textile parts, and store them – in their original packaging – in a cool, dry and dark place when the system will be unused for over 1 month. Prolonged exposure to UV sunlight can shorten the lifespan of textile materials.

## 1.4. Weather care

Components are susceptible to deterioration from use and environmental conditions – such as sunlight, rain, salt and heat – to varying degrees.

If your system will be unused for any extended period, disassemble it, return it to its original packaging and store it in a dry place.



**RAIN:** Remove any fallen debris after rain and wipe off residual water with a dry cloth. Moisture left on the



**WIND:** Disconnect any accessories, and cover the frame with a storm cover.



**HEAT:** Cover when not in use to minimise UV damage.

### COMPONENTS WILL DETERIORATE OVER TIME.

Record your date of purchase here:

	/	/
---	---	---

## 2.0. Usage and behaviour

Improper use of, or behaviour on, your system can lead to serious injury. Please follow these usage and behaviour instructions to ensure safe play.

### 2.1. Safe use information

- Maximum user weight: 750 kg.
- Domestic and outdoor use only.
- Suitable for ages 6 and over.
- Maximum users at one time: 6

### 2.2. Safe use instructions



**ADULT SUPERVISION IS REQUIRED AT ALL TIMES WHILST EQUIPMENT IS IN USE.  
VULY CARES ABOUT SAFETY.**



#### **WARNING:**

To reduce the risk of injury while using the system, enforce the following:

- Ensure that the system has been assembled by an adult, in accordance with the assembly instructions.
- Ensure that the system has been checked over before use, and that all attachments are secure.
- Do not use in strong wind conditions or wet weather, and keep the system secure.
- Ensure active and competent adult supervision at all times while children are using the system.
- Wear comfortable clothing, which allows full and free movement, and closed-in footwear.
- Ensure that the system has been checked over before use, and that all attachments are secure.
  - Do not wear jewellery, drawstrings, cords, loops, buckles or anything that could entangle in components and become a strangulation hazard, a contact hazard or damage the system
  - Empty pockets and hands before use
- Exercise caution at heights.
- Make sure that the areas around, underneath and above the system are clear.
- Demonstrate safe use for children before allowing them onto the system.
- Do not walk close to, in front of, behind, or between moving items.
- Do not attach items that are not specifically designed for use with the system, such as – but not limited to – jump ropes, clothesline, pet leashes, cables and chains.
- Install the system on level ground and in a well-lit area, no less than 2 m (6 ft) from any structure or obstruction – such as a fence, garage, house, overhanging branches, laundry lines, or electrical wires.
- Ensure that your chosen surface allows the system to be firmly embedded with the included Anchor Kit or with strong bolts.
- Preference installing the system on a surface with impact-attenuating properties – such as grass. A fall onto a hard surface can result in serious injury or death to the equipment user.
- Check that you have all parts required for assembly.
- Lock nuts and bolts securely.
- Children must not use the equipment until properly installed.

## 3.0. Pre-assembly

### 3.1. Size Reference

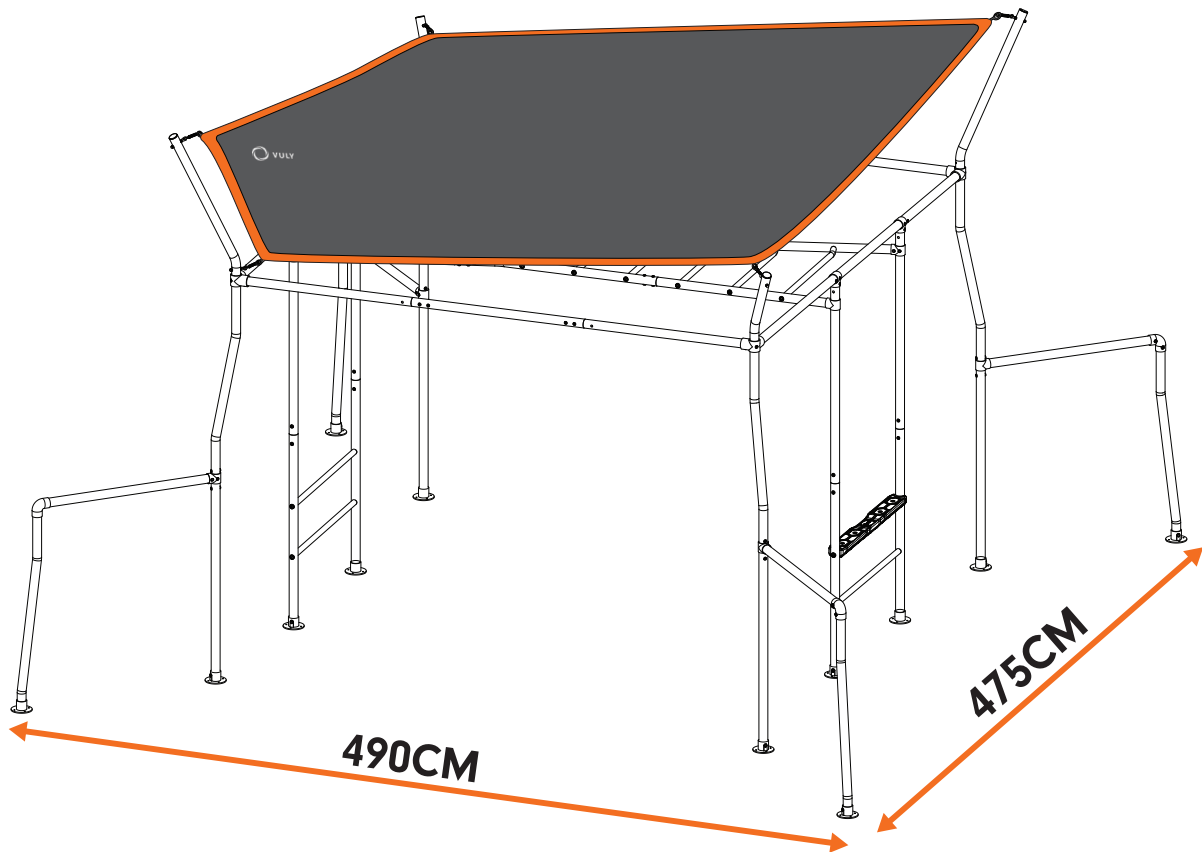

### 3.2. Tips & Tricks

#### 3.2.1. Joiner Fitting

Difficulty in inserting joiners to frame tubes can be resolved by inverting the tube and tapping the internal joiner against a scrap piece of wood.

To align the joiner holes with the holes in the frame tube, take the large 8mm Allen key and insert it into the top hole in the joiner tube then twist until the holes align. If further alignment is required, remove the Allen key and place it through the holes in the joiner and the tube. Use the Allen key to leverage the holes into alignment.

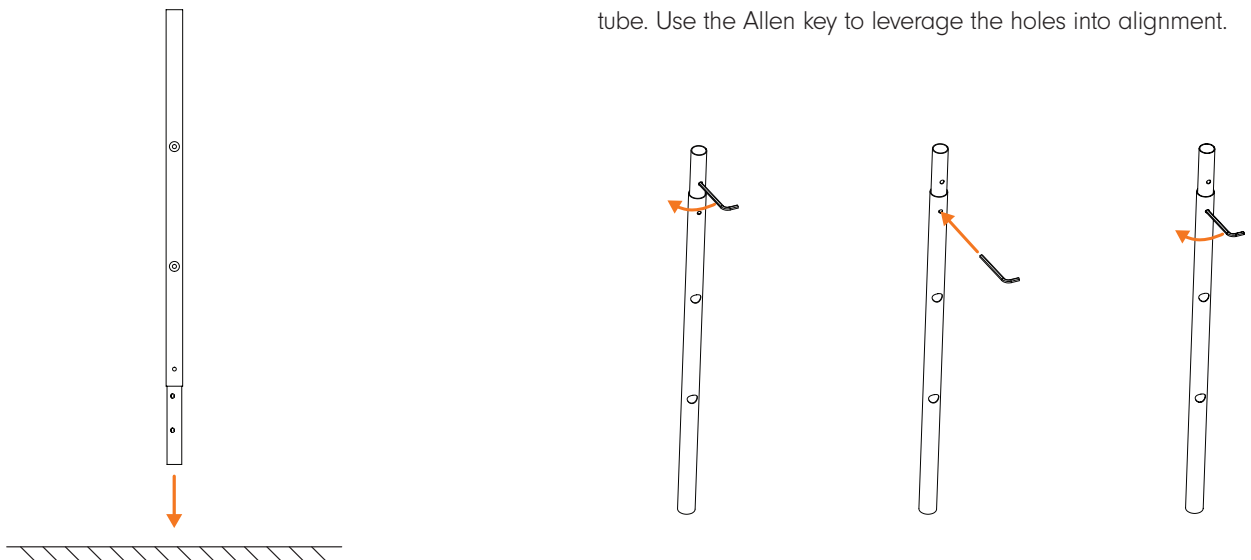

### 3.2.2. Uneven Ground

If assembling the Quest on uneven ground adjusting the flip rails will reduce rocking. If the Quest still seems unsteady, loosen the feet and move them down slightly.

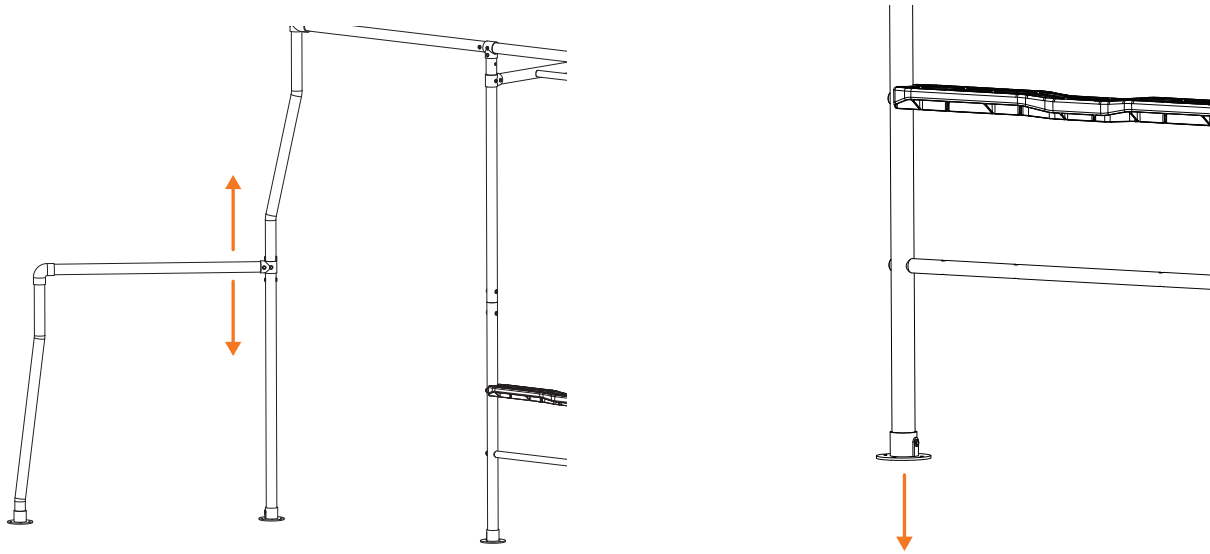

### 3.2.3. Exploded View

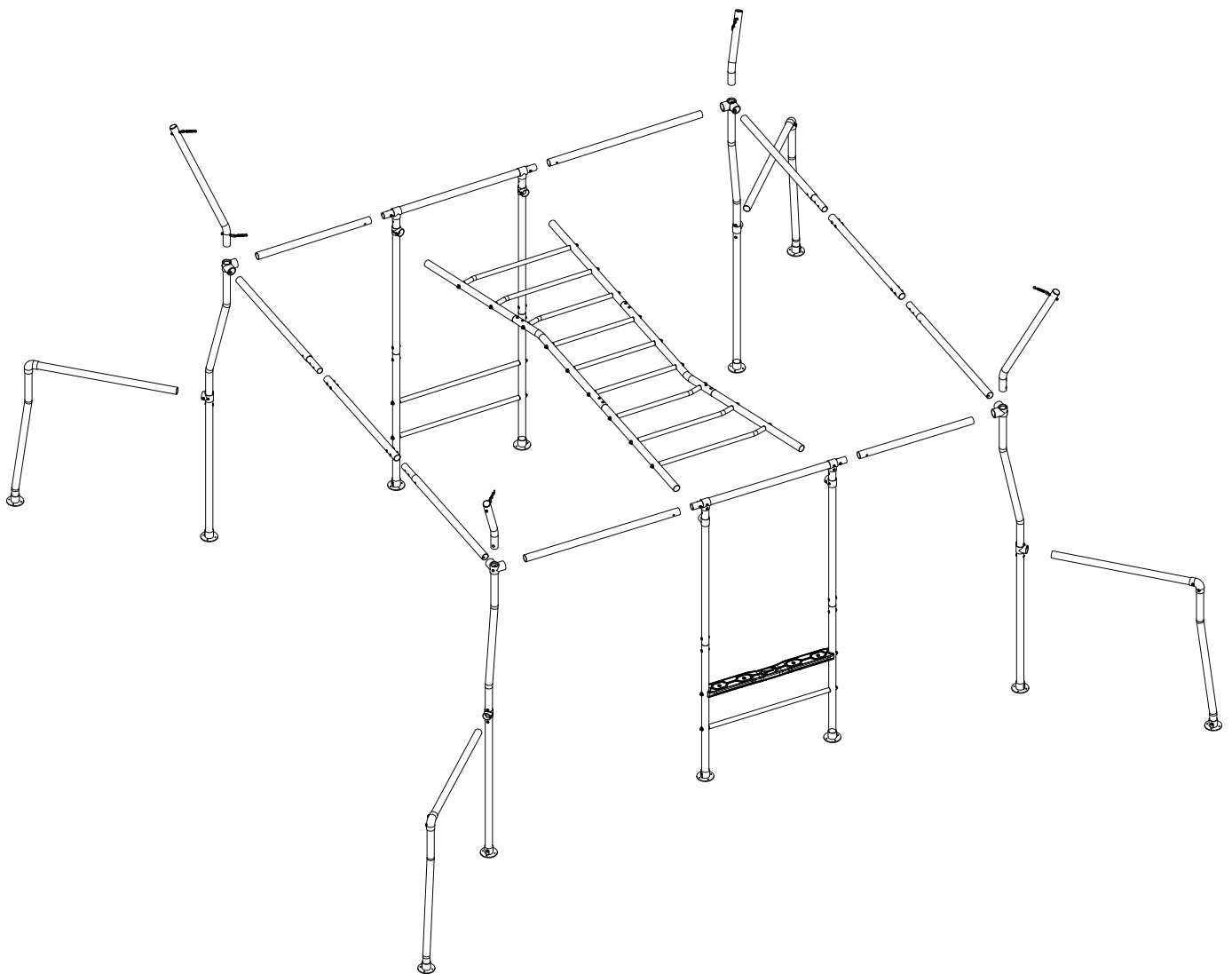

**!** DO NOT REMOVE PARTS FROM CARTONS UNTIL REQUIRED, OR MIX CARTON CONTENTS.

# BOX A

**A1** 2X

**A2** 2X

**A3** 2X

**A4** 2X

**A5** 2X

**A6** 2X

**A7** 3X

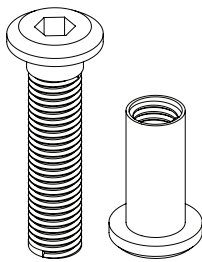

**A8**  
8X

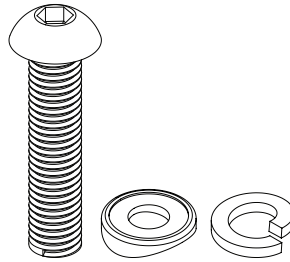

**A9**  
18X

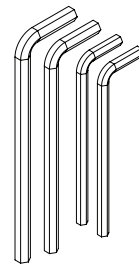

**A10**  
1X

# BOX B

**B1** 4X

**B2** 3X

**B3** 1X

**B4** 1X

**B5** 8X

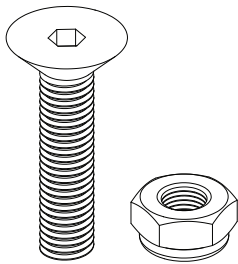

**B6**  
4X

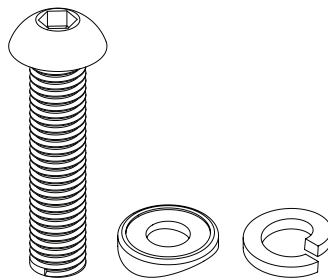

**B7**  
8X

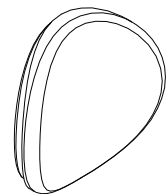

**B8**  
2X

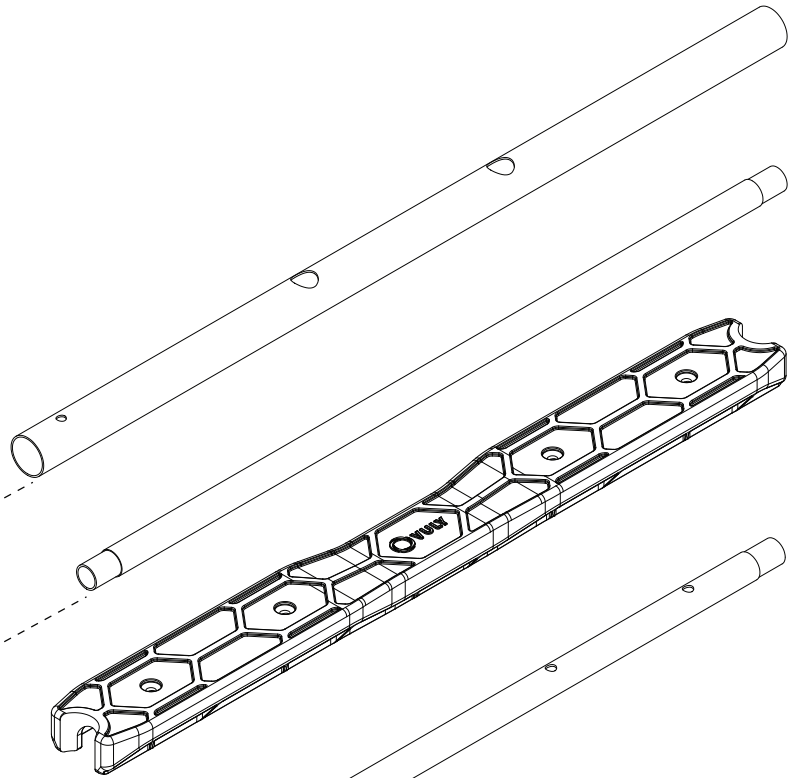

# BOX C

**C1**

4X

**C2**

4X

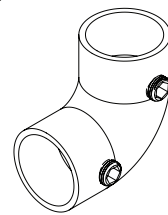

**C3**

4X

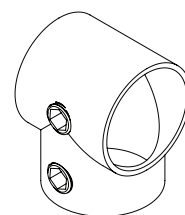

**C4**

4X

# BOX E

**2X**

**E1**

2X

**E2**

1X

**E3**

1X

**E4**

1X

**E5**

6X

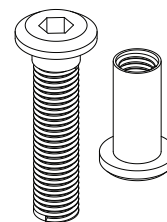

# BOX F

## 2X

**F1** 2X

**F2** 2X

**F3** 2X

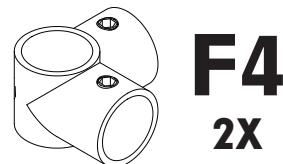
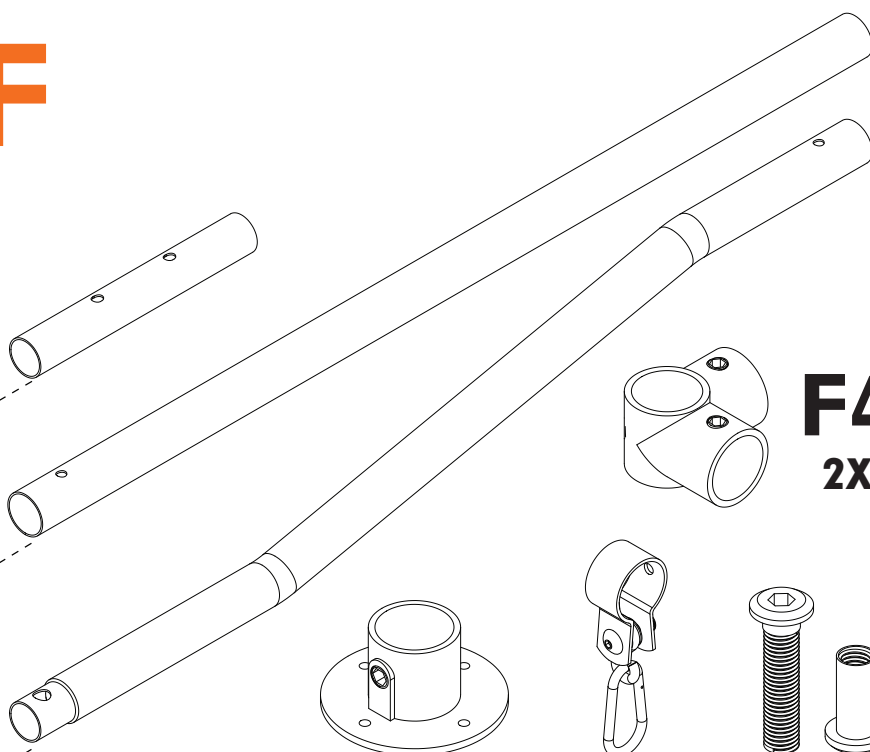

**F4**  
2X

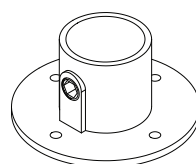

**F5**  
2X



**F6**  
7X

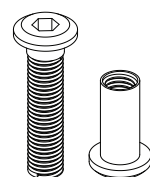

**F7**  
4X

# BOX H

**H1** 4X

**H2** 2X

**H3** 4X

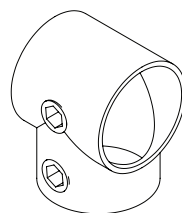
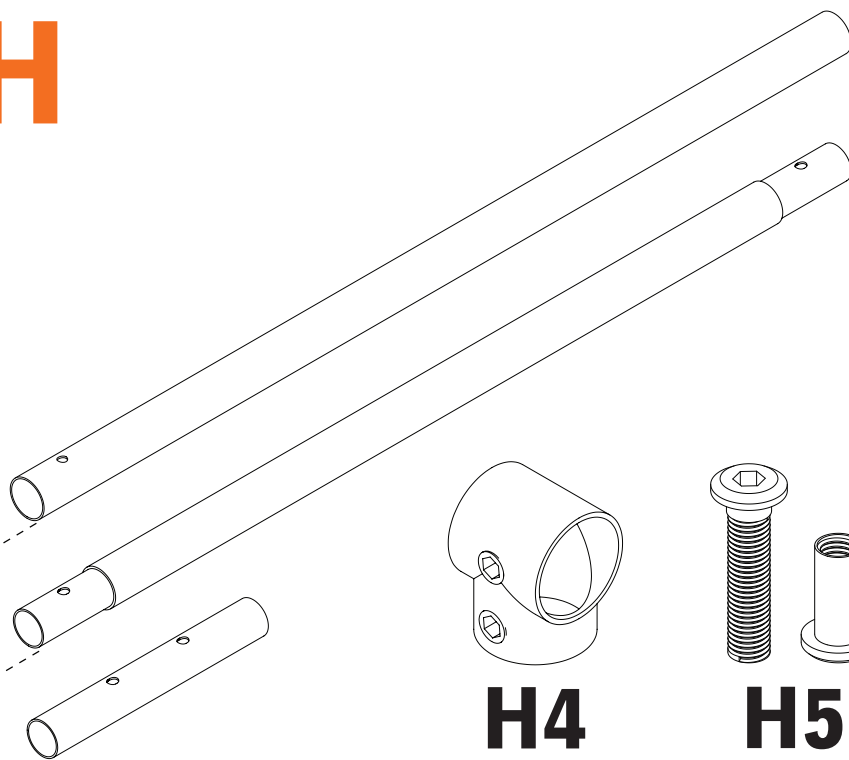

**H4**  
8X

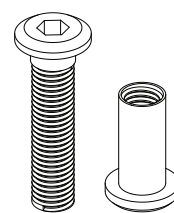

**H5**  
8X

# BOX SHADE COVER

**XL1**

2X

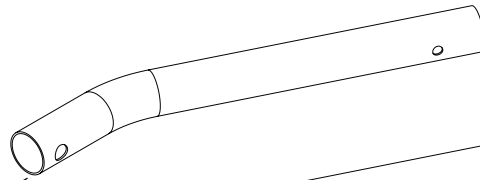

**XL2**

2X

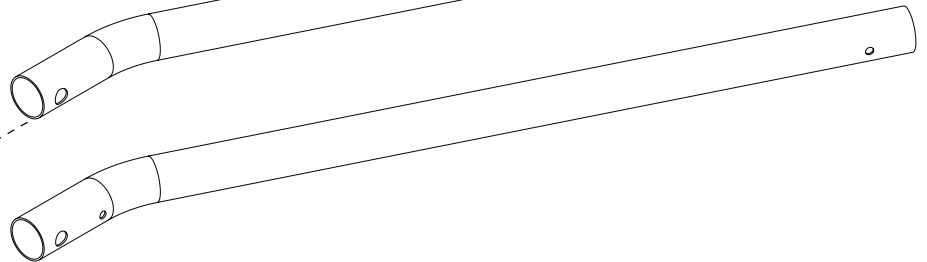

**XL5**

48X

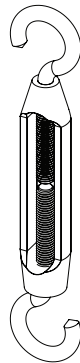

**XL6**

5X

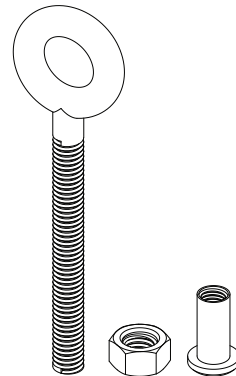

**XL7**

5X

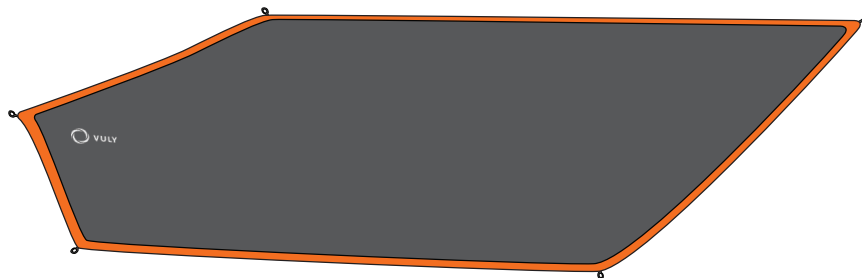

1X

# 1

## CLIMBING RAIL

scan this QR code for video instruction:



### PRE-ASSEMBLY

You will require the following: • Ladder • Rubber mallet • Tape measure or ruler

ENSURE THAT AS YOU ASSEMBLE THE PRODUCT, YOU FIRMLY TIGHTEN ALL NUTS AND BOLTS, UNLESS DIRECTED.

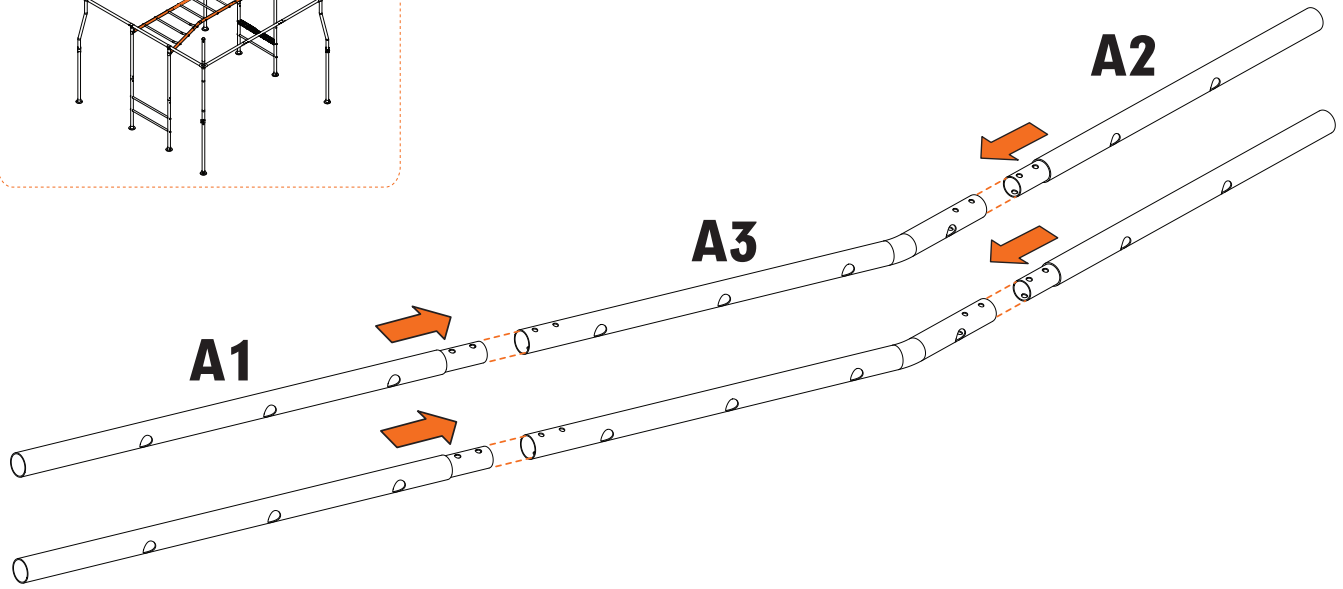
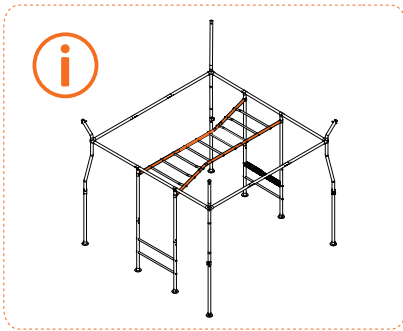

# 2

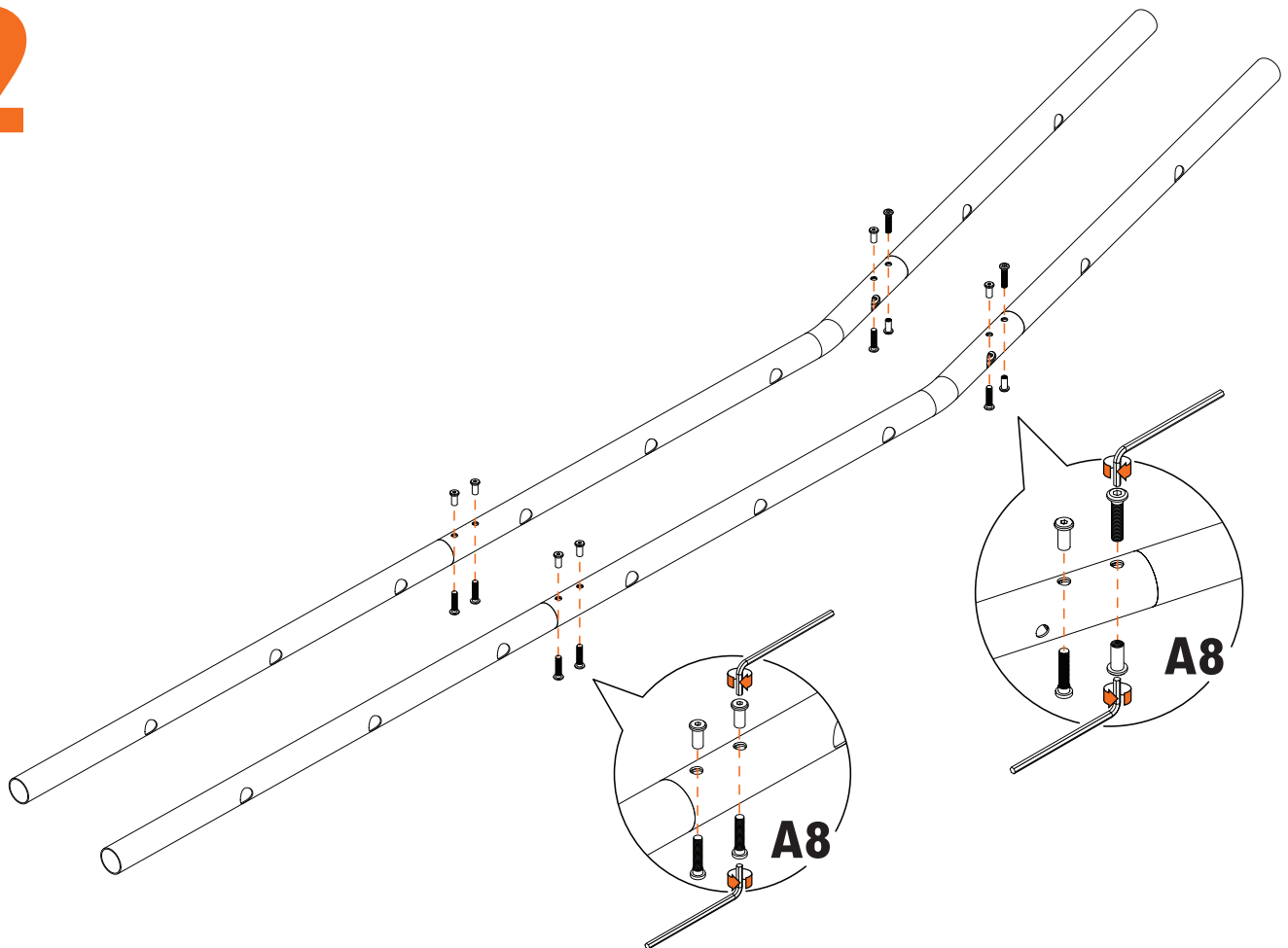

# 3

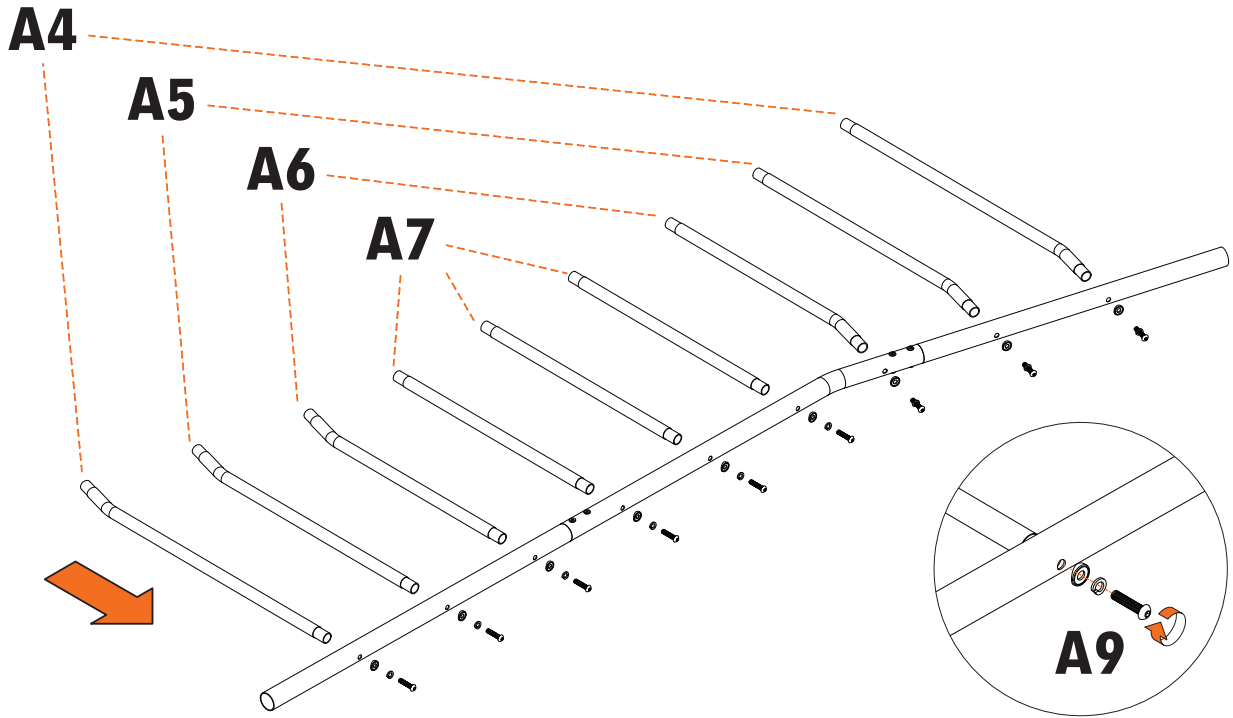

**HAND TIGHT THE BOLTS AND MAKE SURE THEY ARE VERY LOOSE.** You may need to rotate some Monkey Bars to fit into the remaining Climbing Rail.

# 4

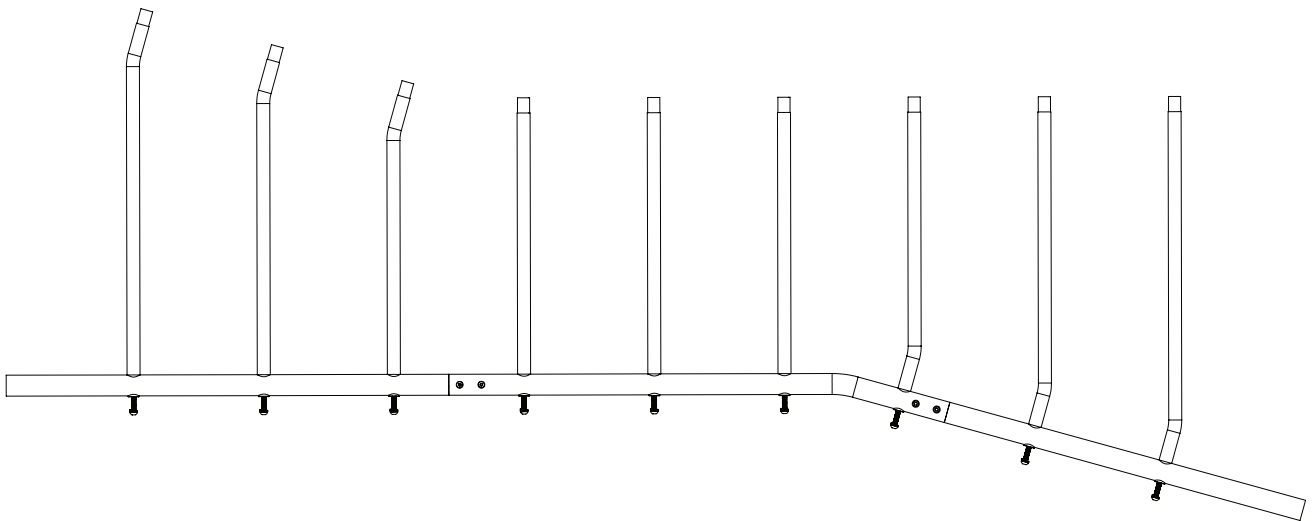

Make sure that the straight Climbing Bars are in the middle, and the angled Climbing Bars are in the either ends of the Climbing Rails, as indicated above.

# 5

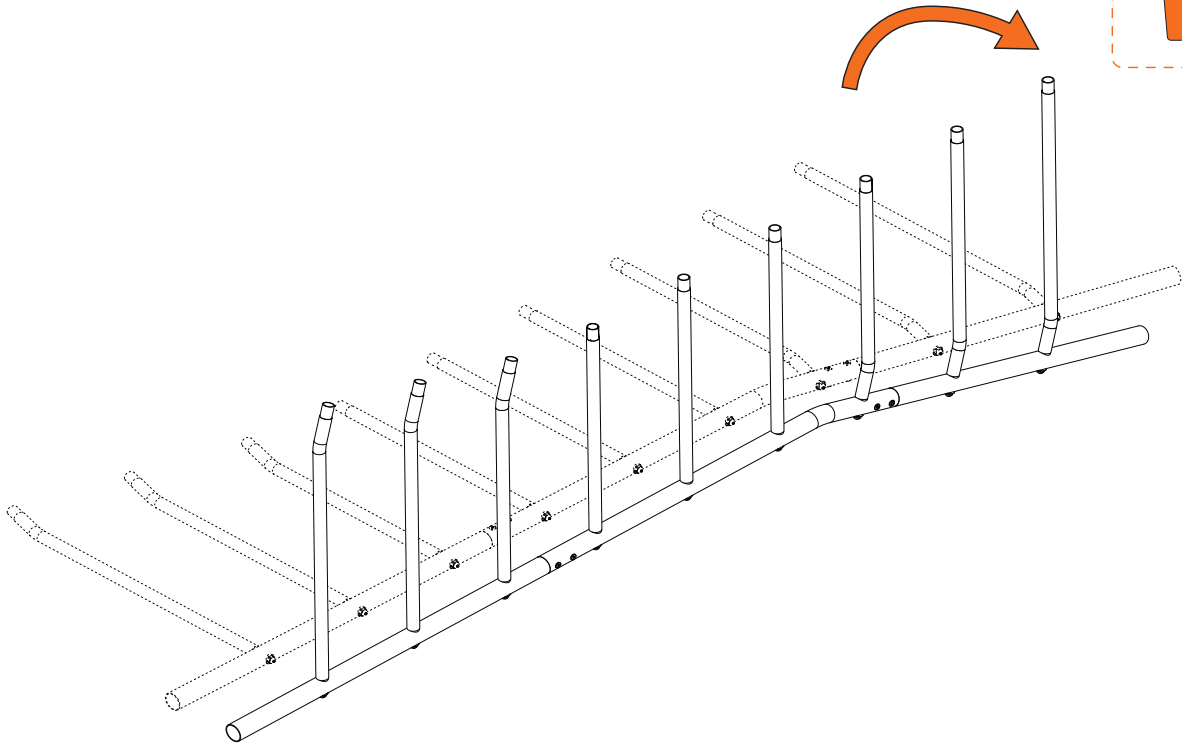
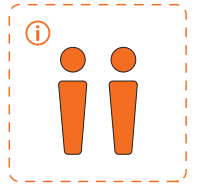

# 6

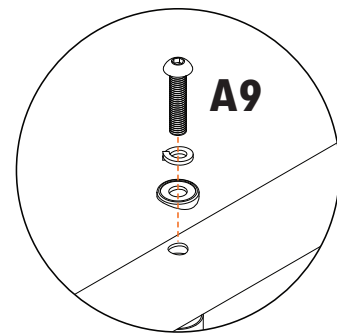
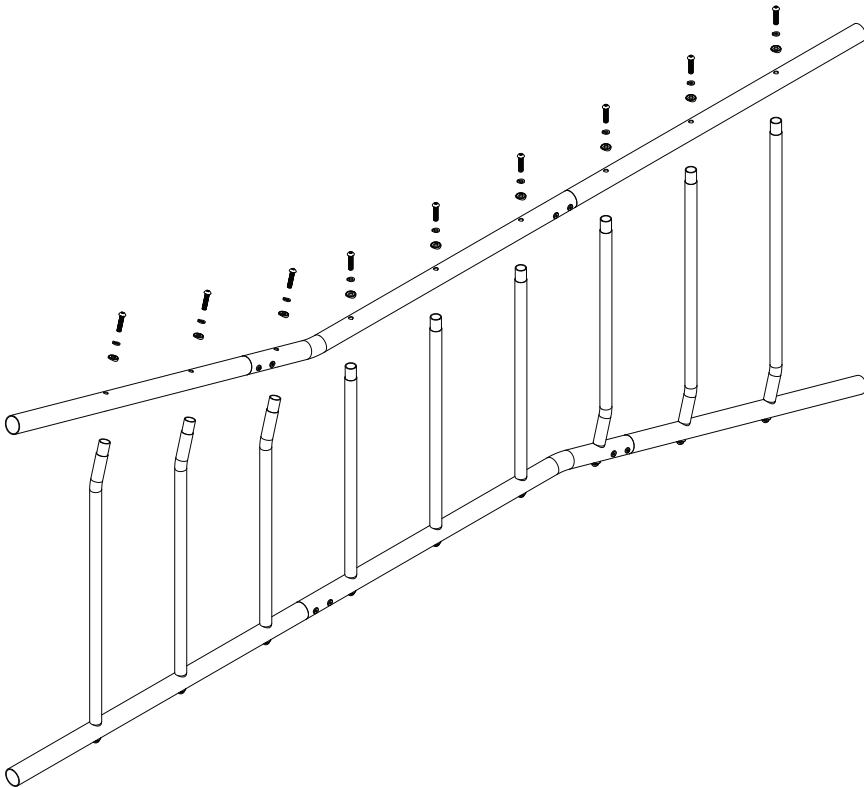

**ONLY HAND TIGHT THE BOLTS AND MAKE SURE THEY ARE VERY LOOSE.**

If having difficulties to get the Climbing Bars into the climbing Rails, double check to make sure all the bolts done in Step 3 remain very loose.

# 7

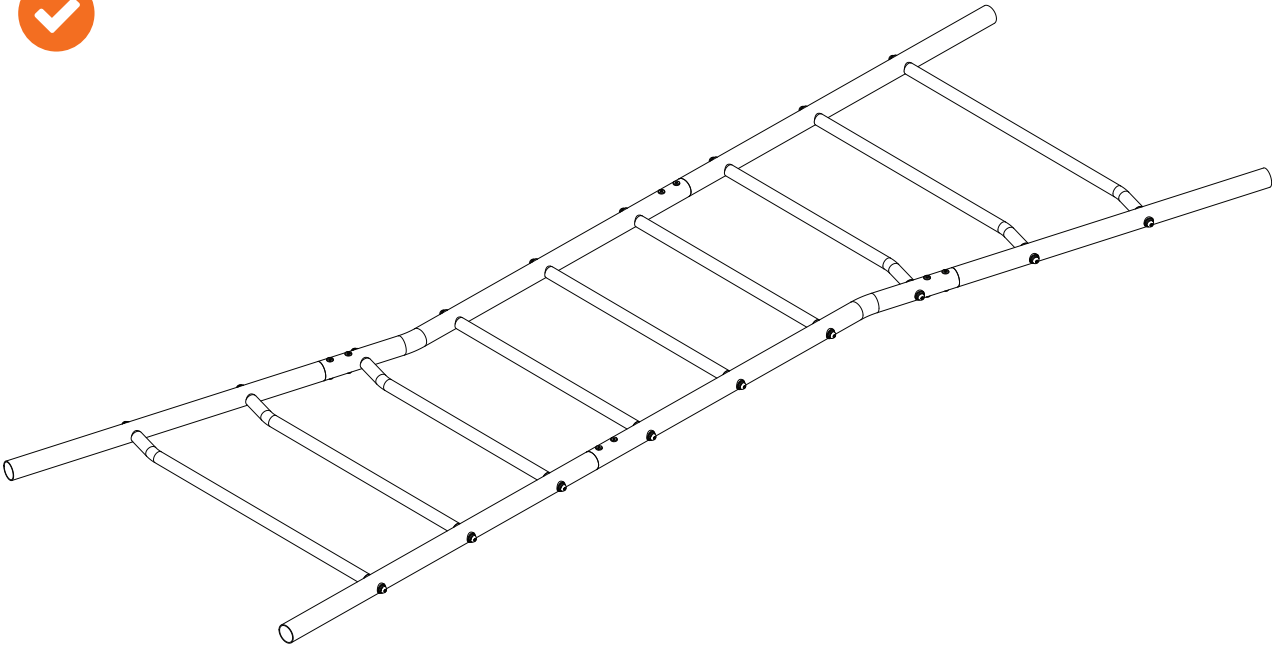

Once all of the climbing bars are loosely threaded into the climbing rails, tighten all of the bolts to make sure the climbing section is secure.

# 8

## FRAME

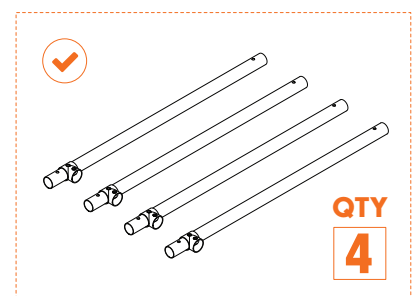
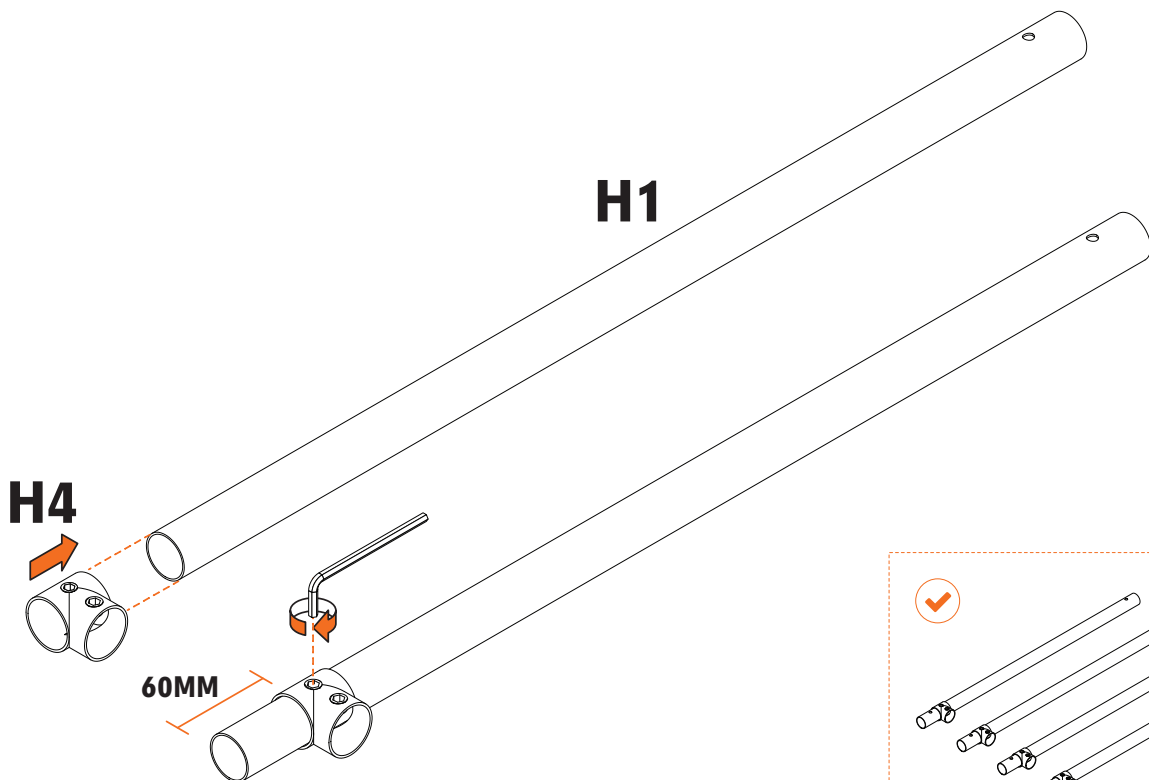

# 9

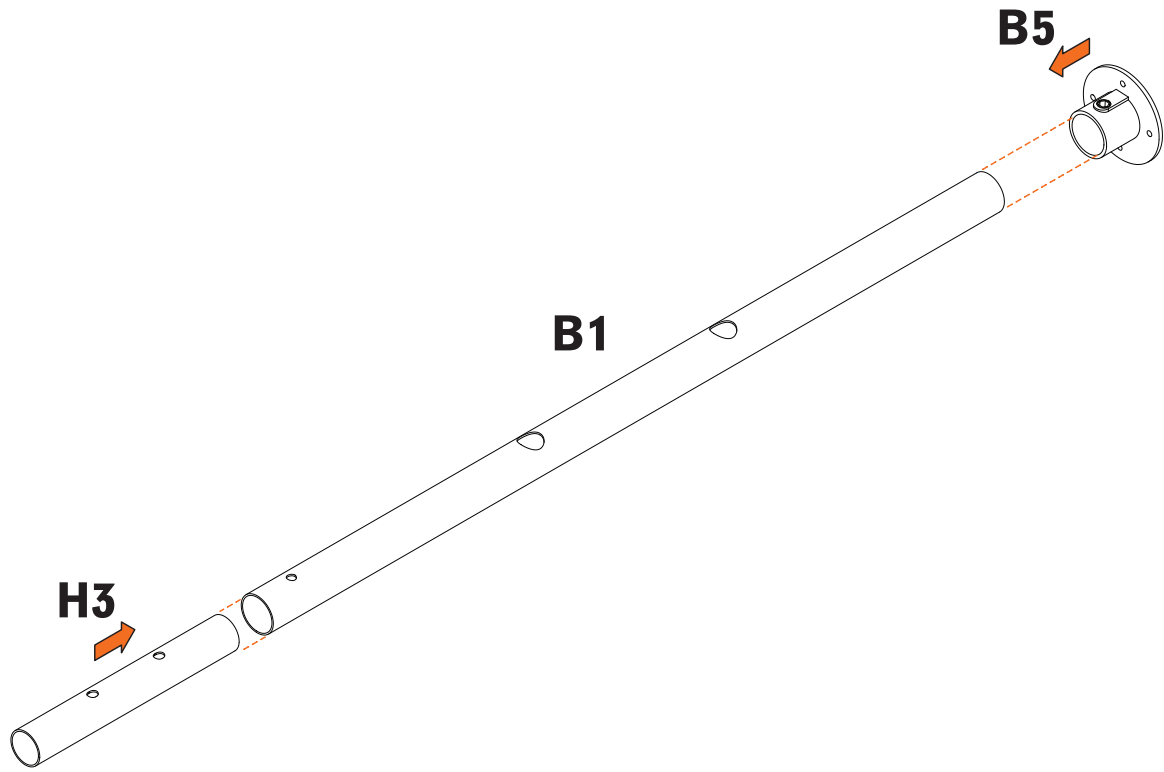

**⚠ WARNING:** Ensure that you align these parts correctly. Once inserted, they will be very difficult to remove or adjust.

# 10

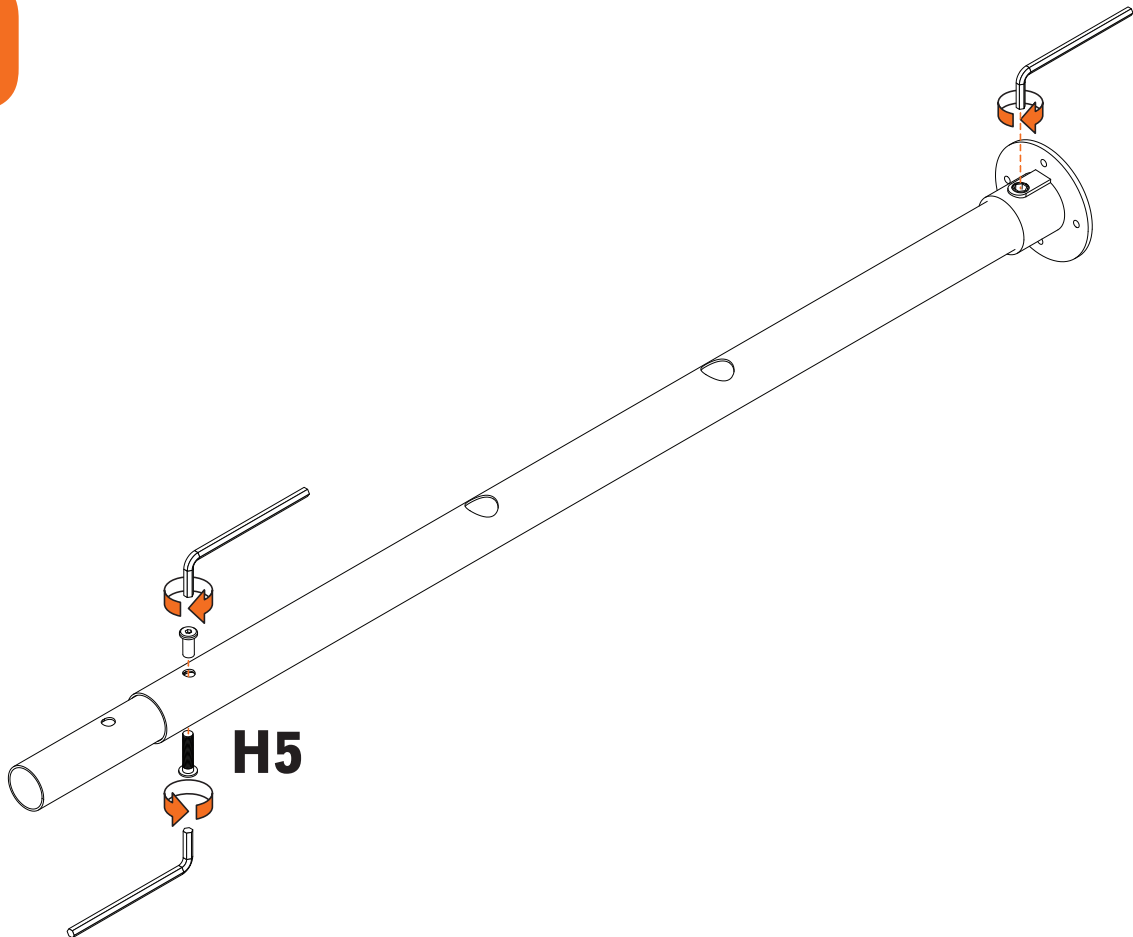

# 11

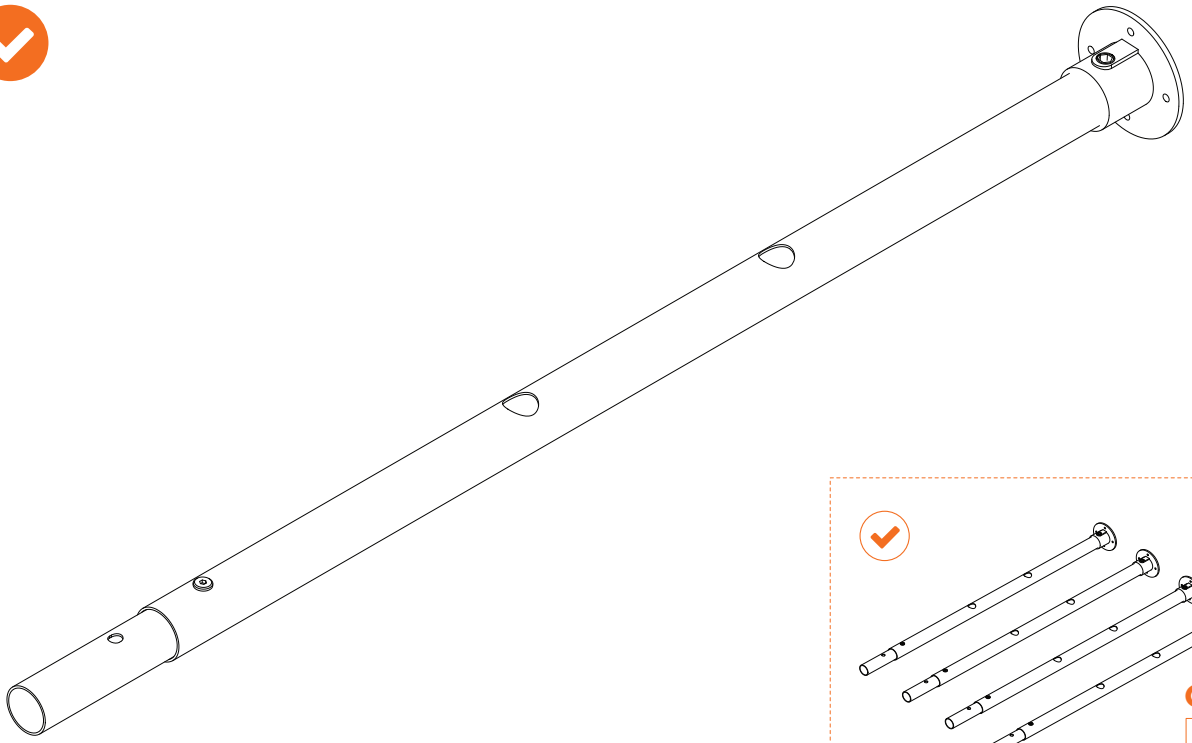

# 12

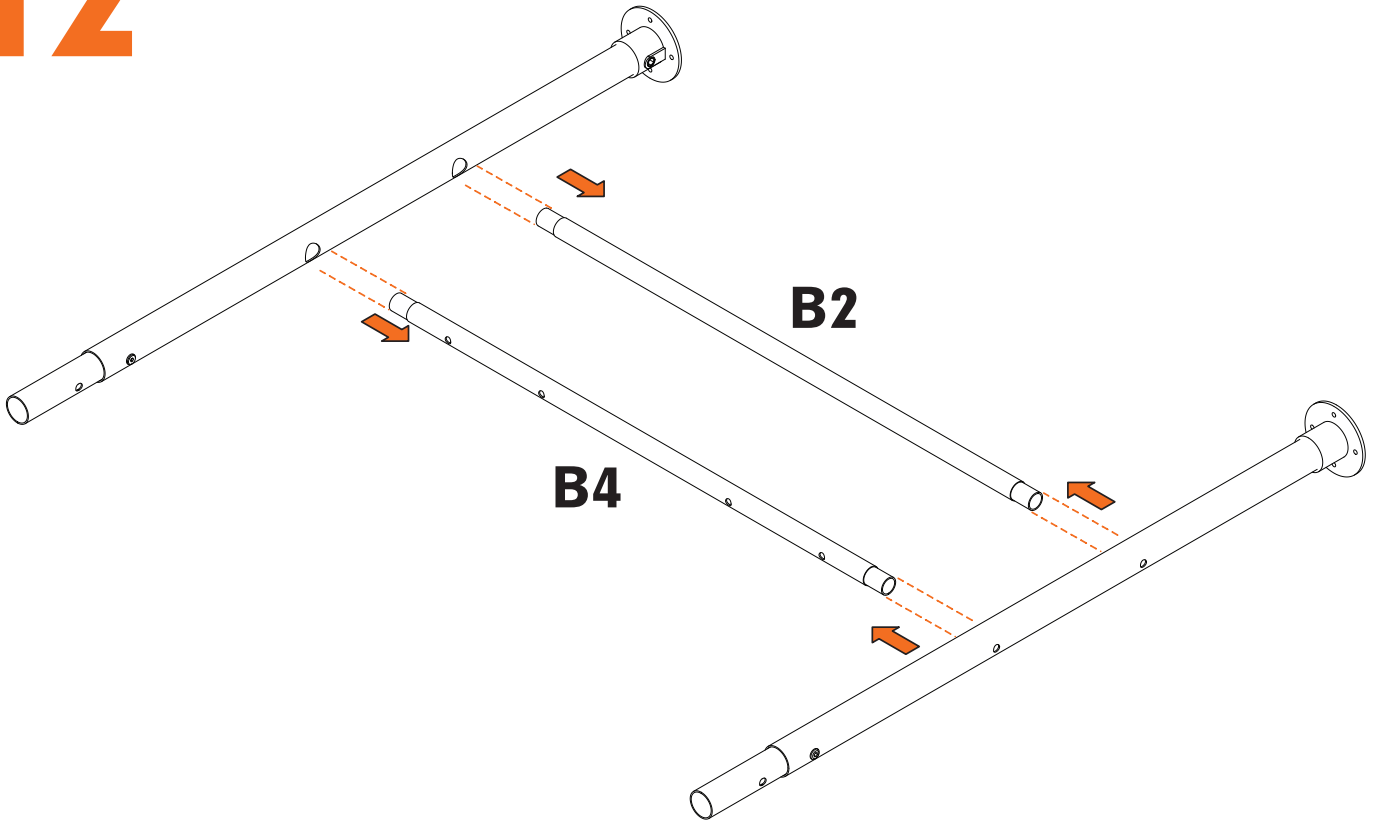

# 13

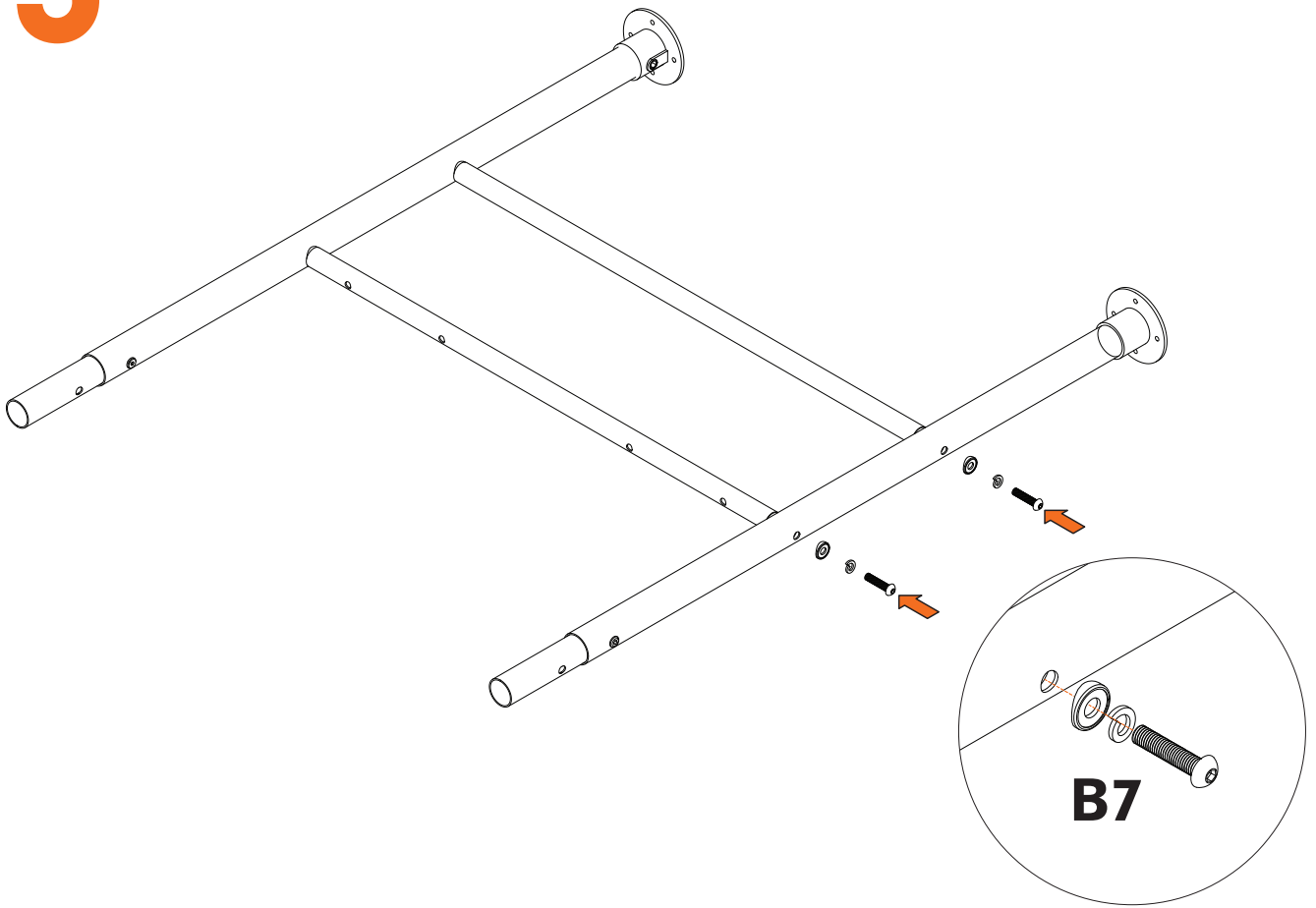

# 14

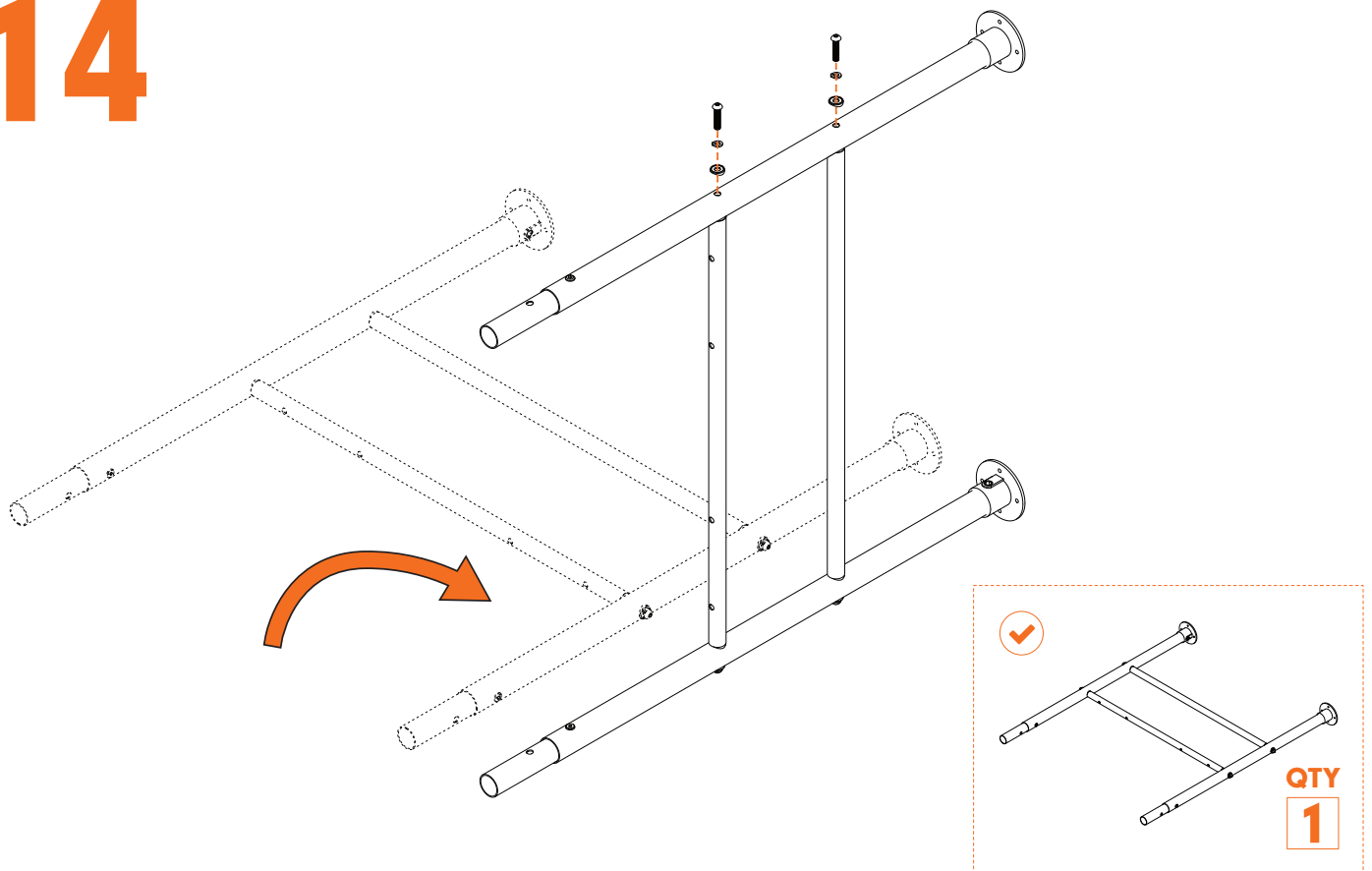

YOU HAVE A CARGO NET? SKIP TO STEP 19



# 15

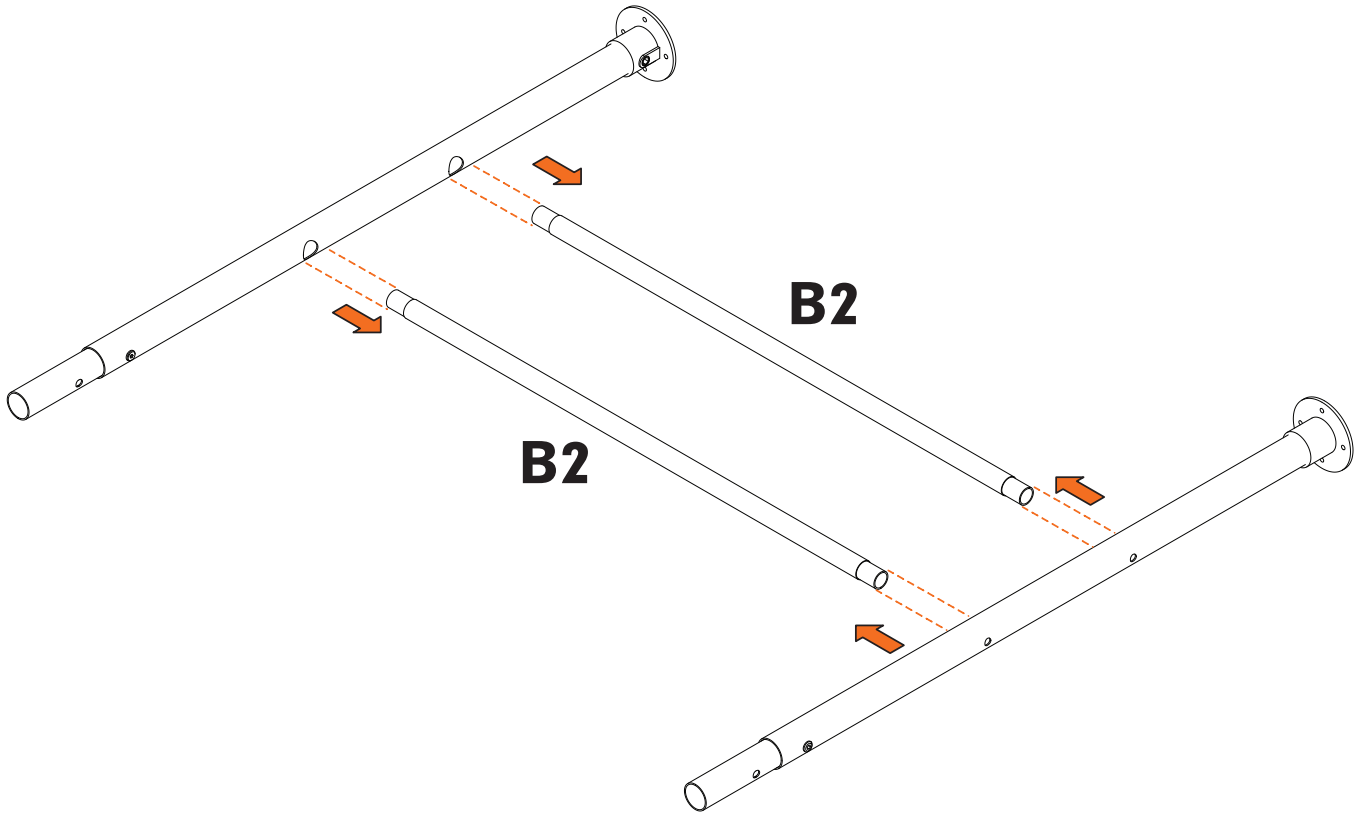

# 16

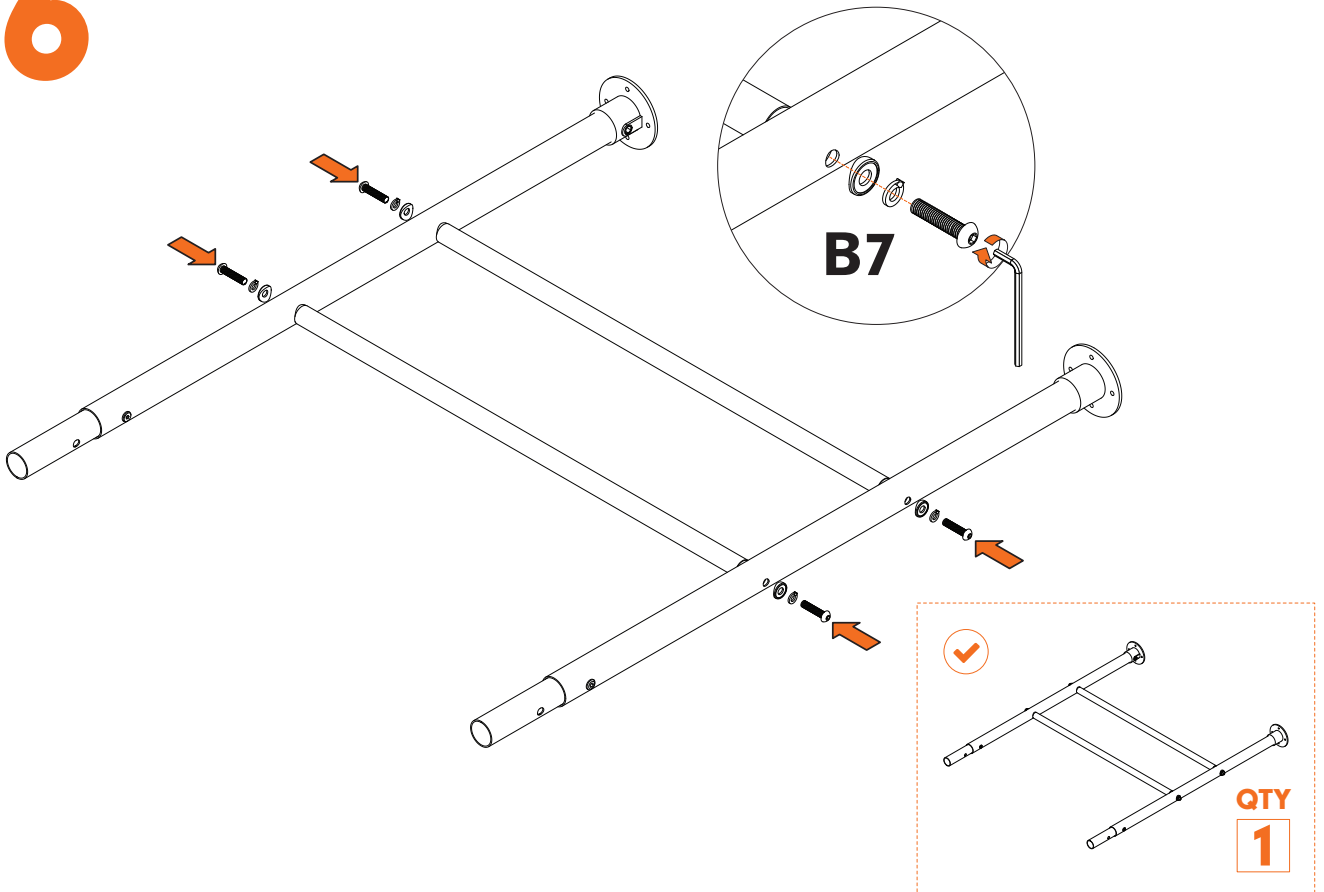

# 17

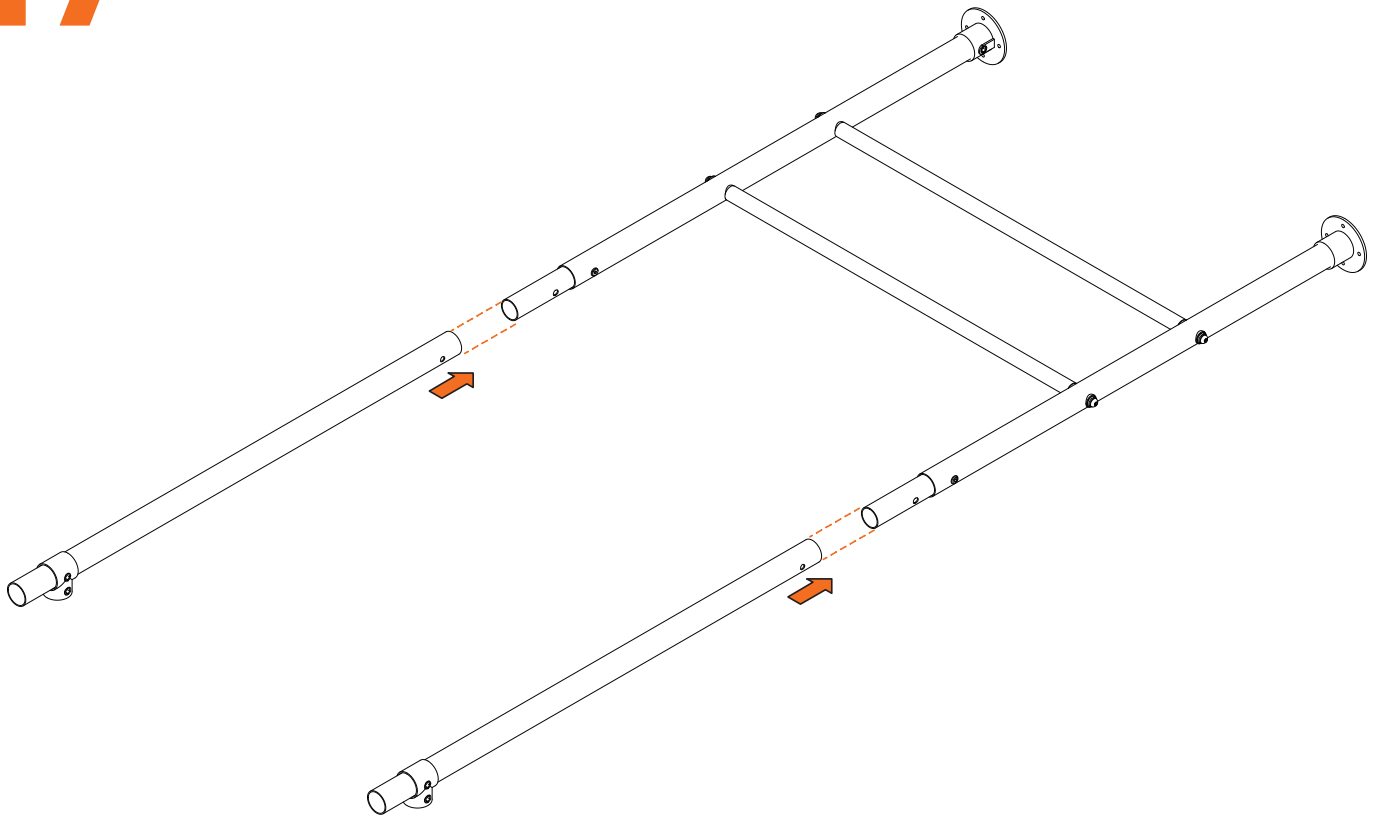

# 18

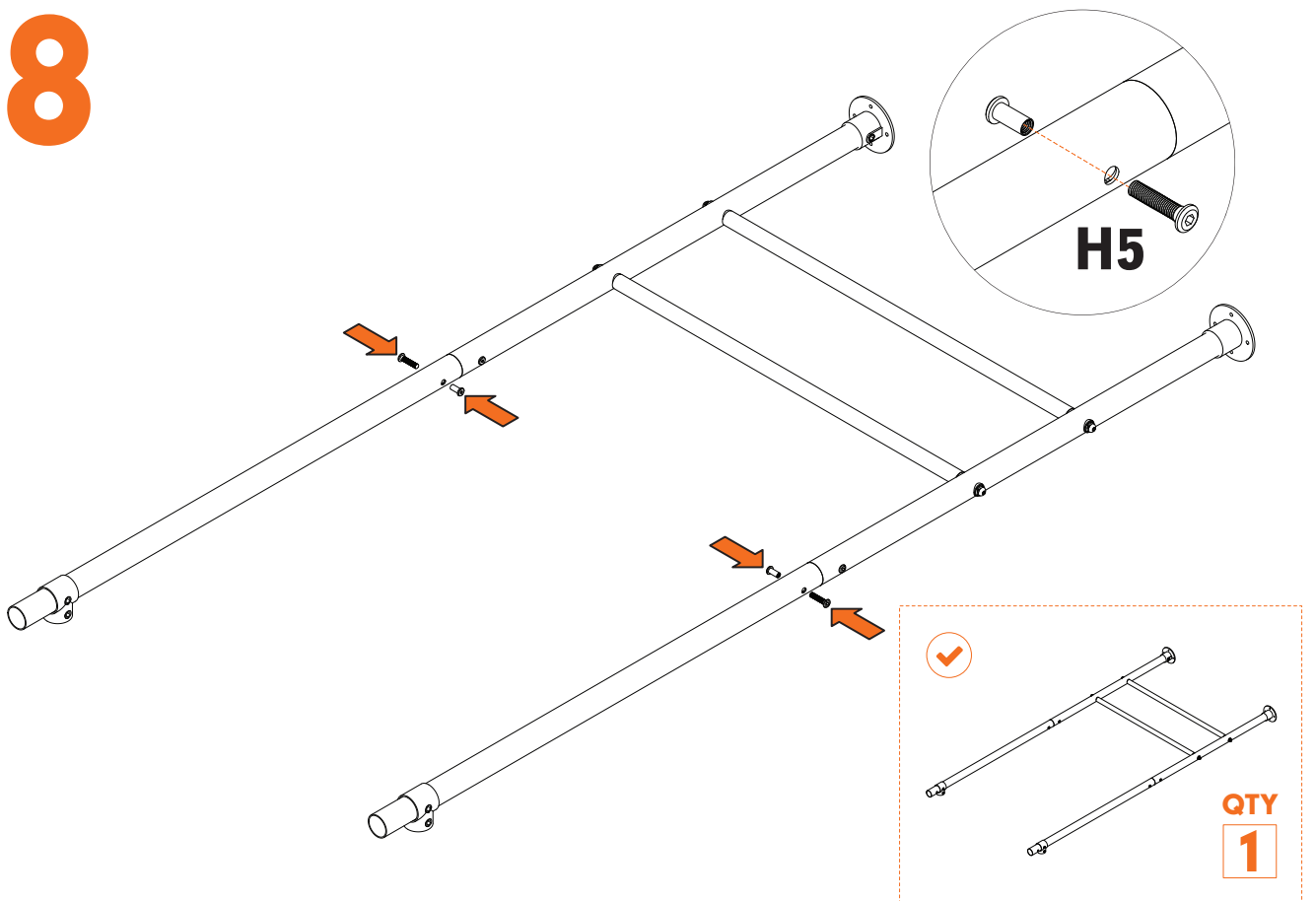

 **NO CARGO NET? SKIP TO STEP 25** 

# 19

## CARGO NET ASSEMBLY



NO CARGO NET? SKIP TO STEP 25

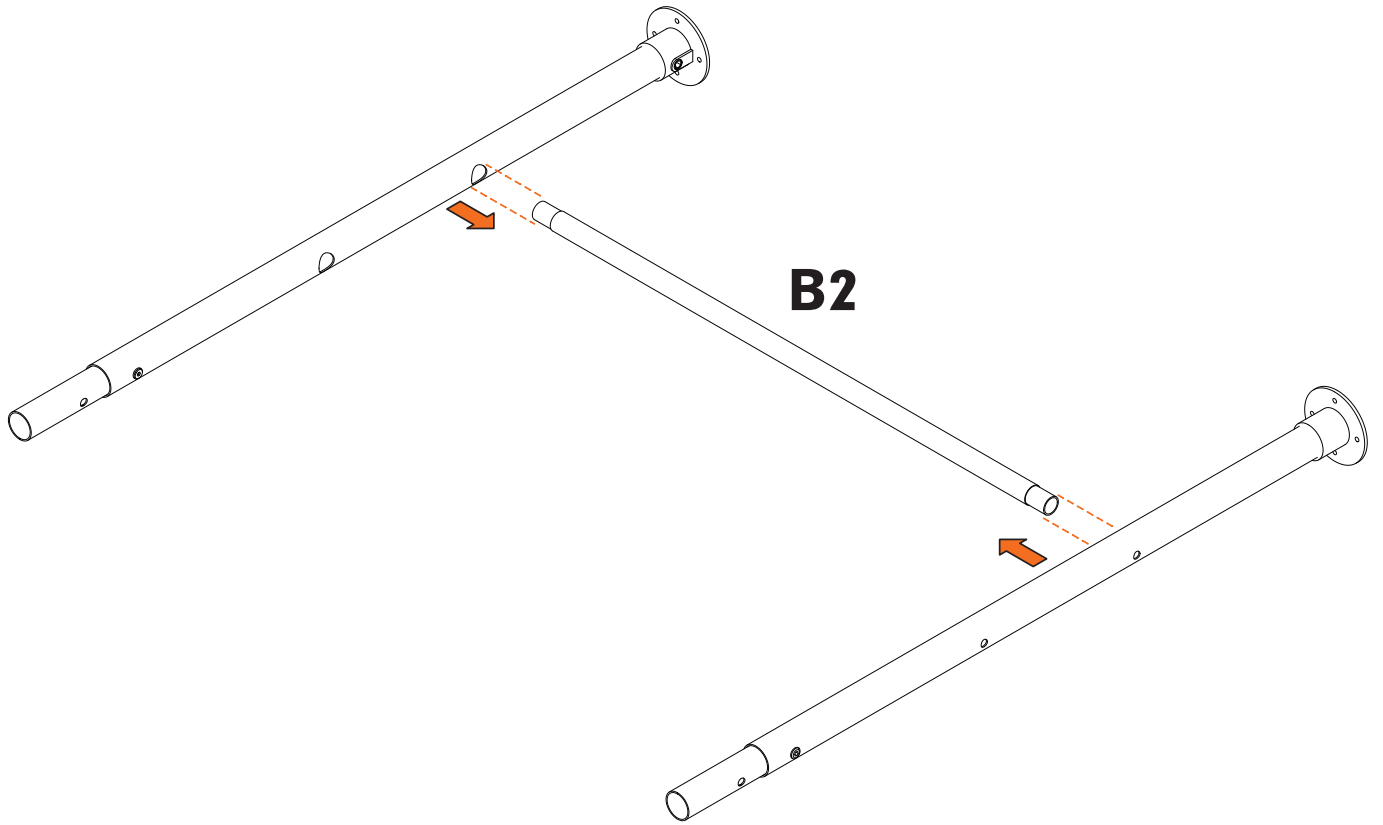

# 20

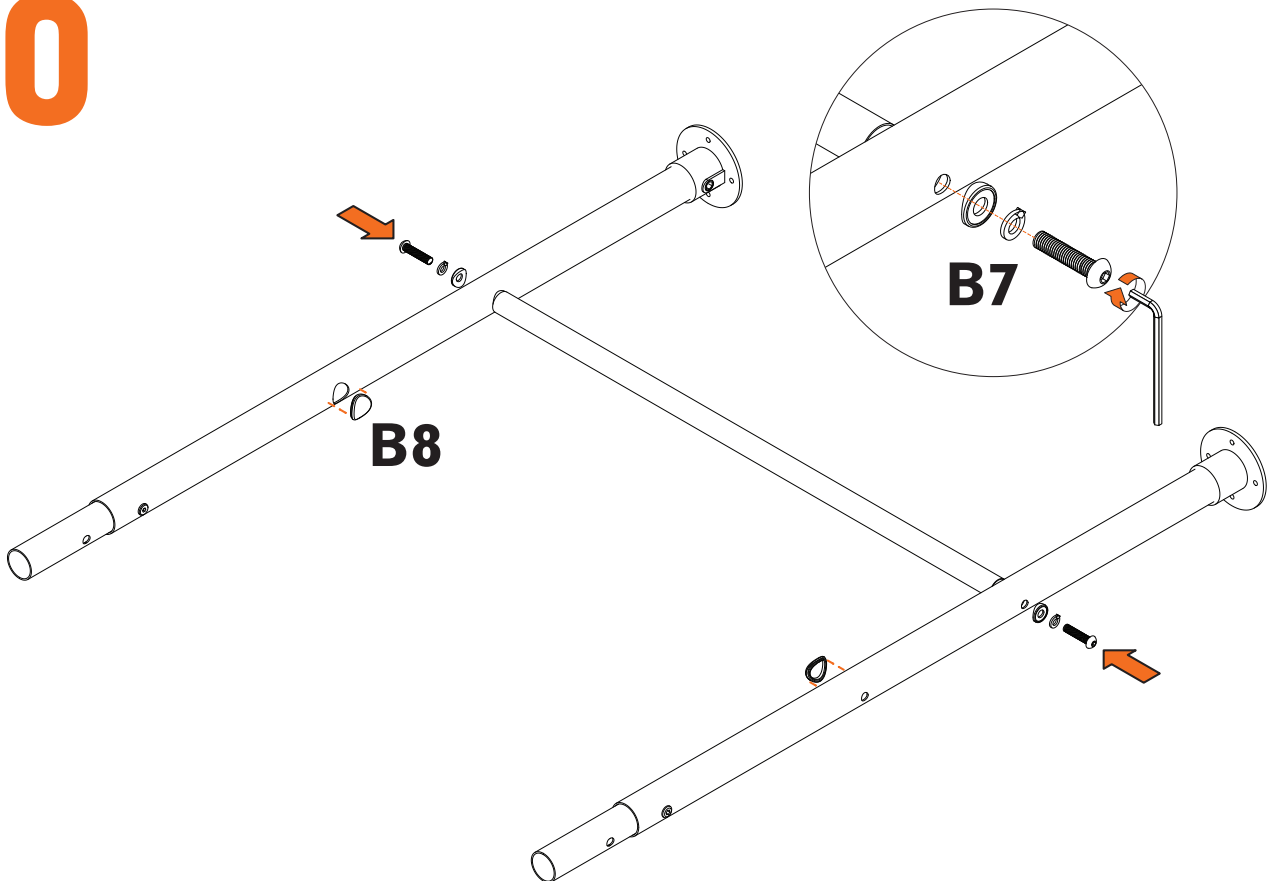

# 21

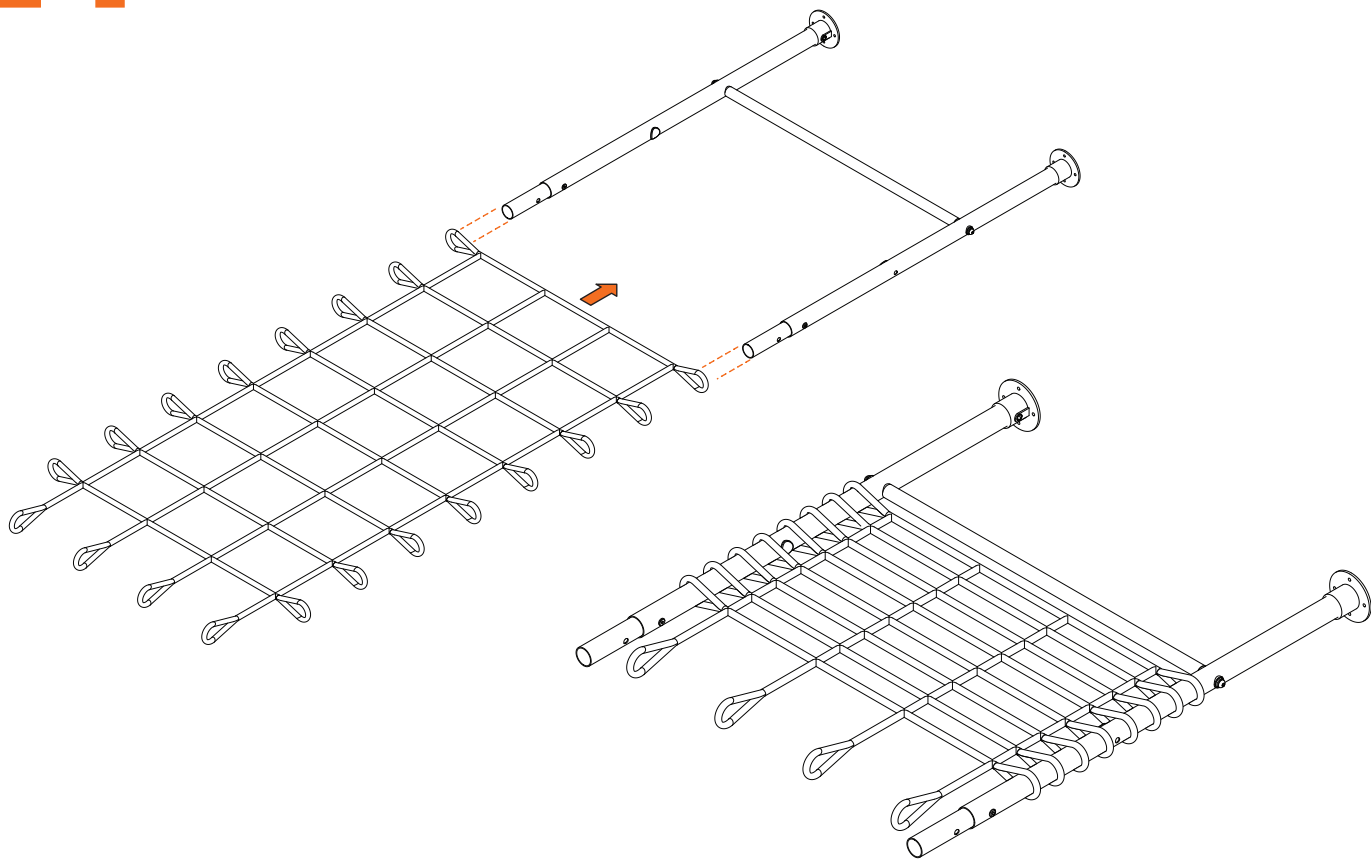

# 22

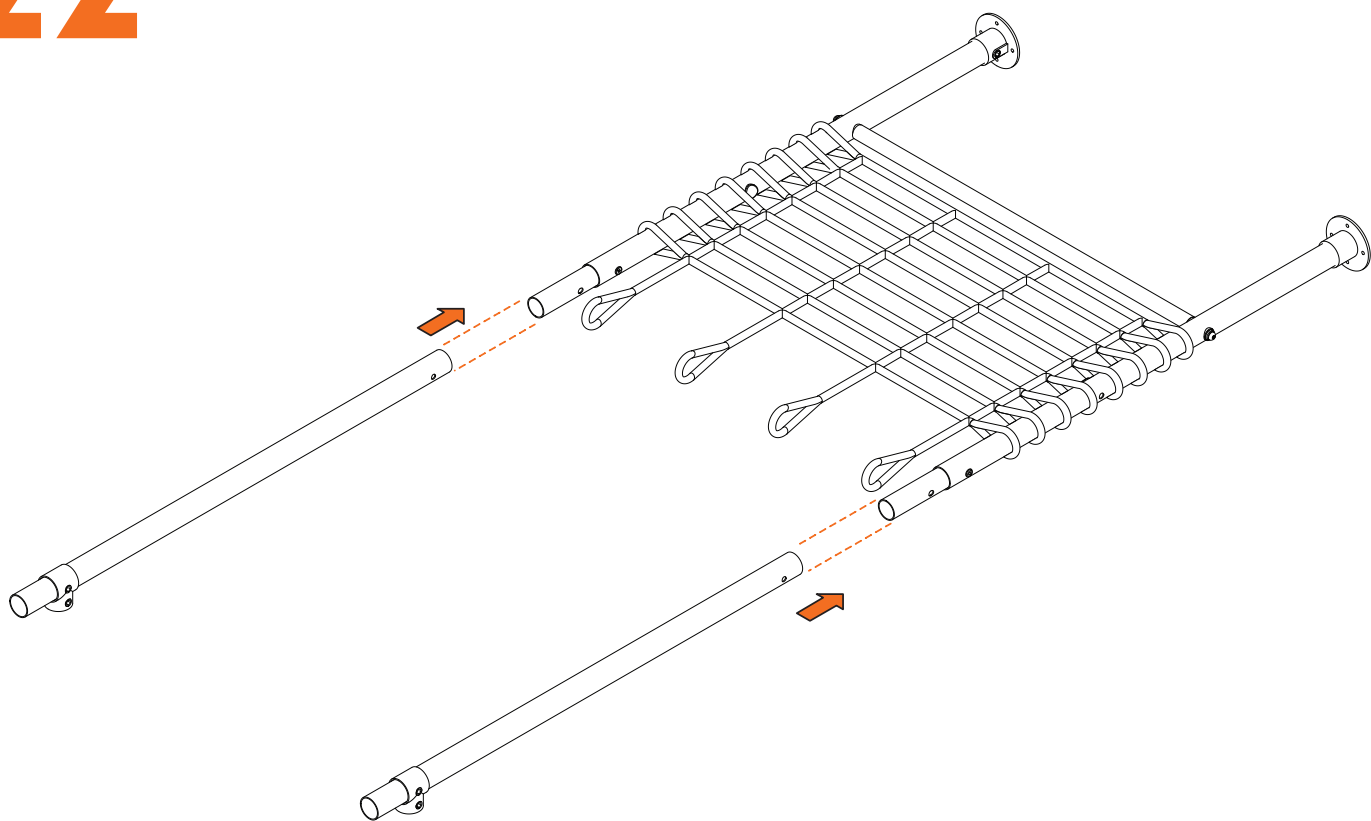

# 23

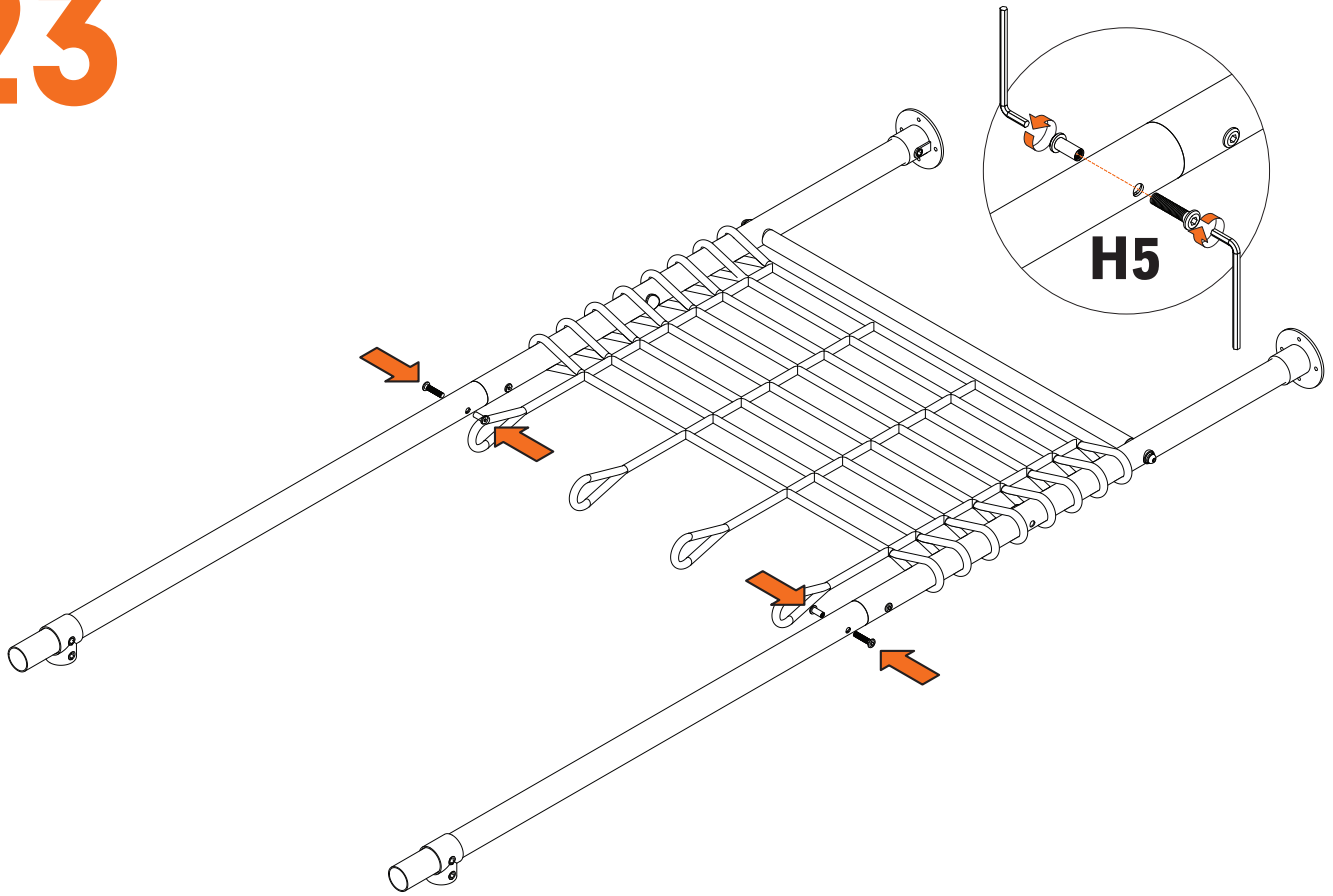

# 24

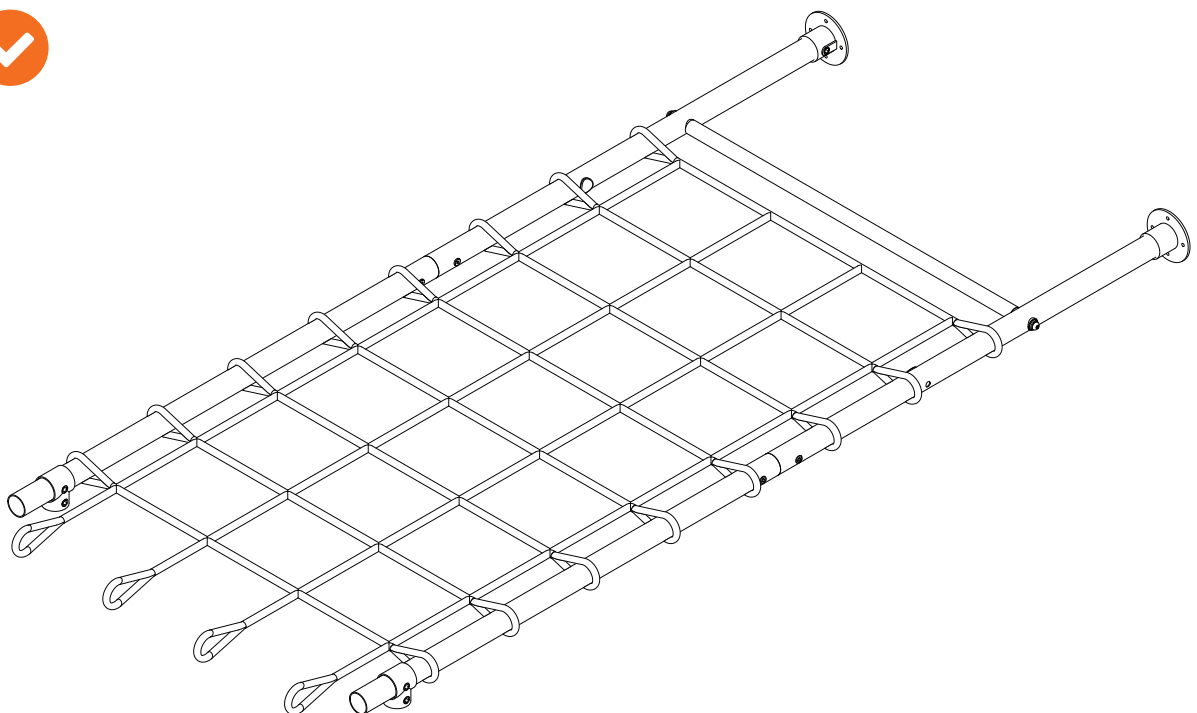

# 25

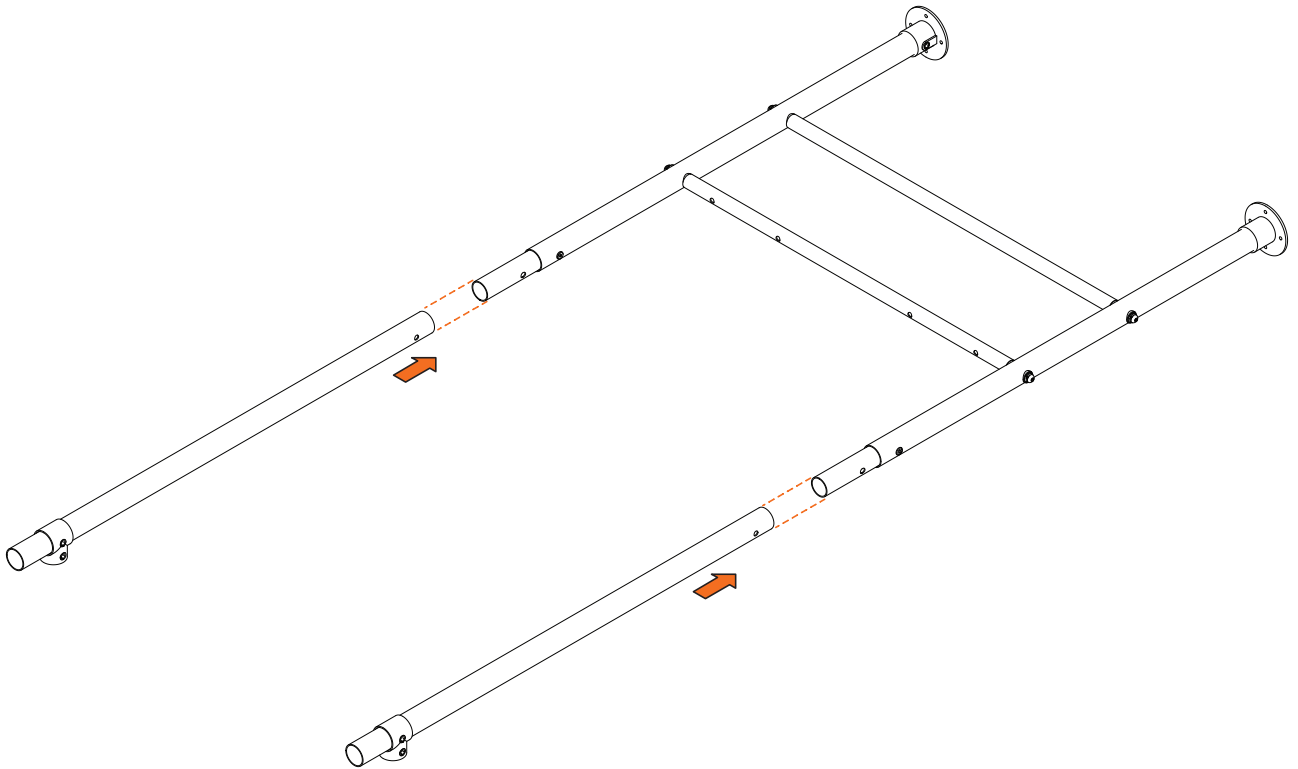

# 26

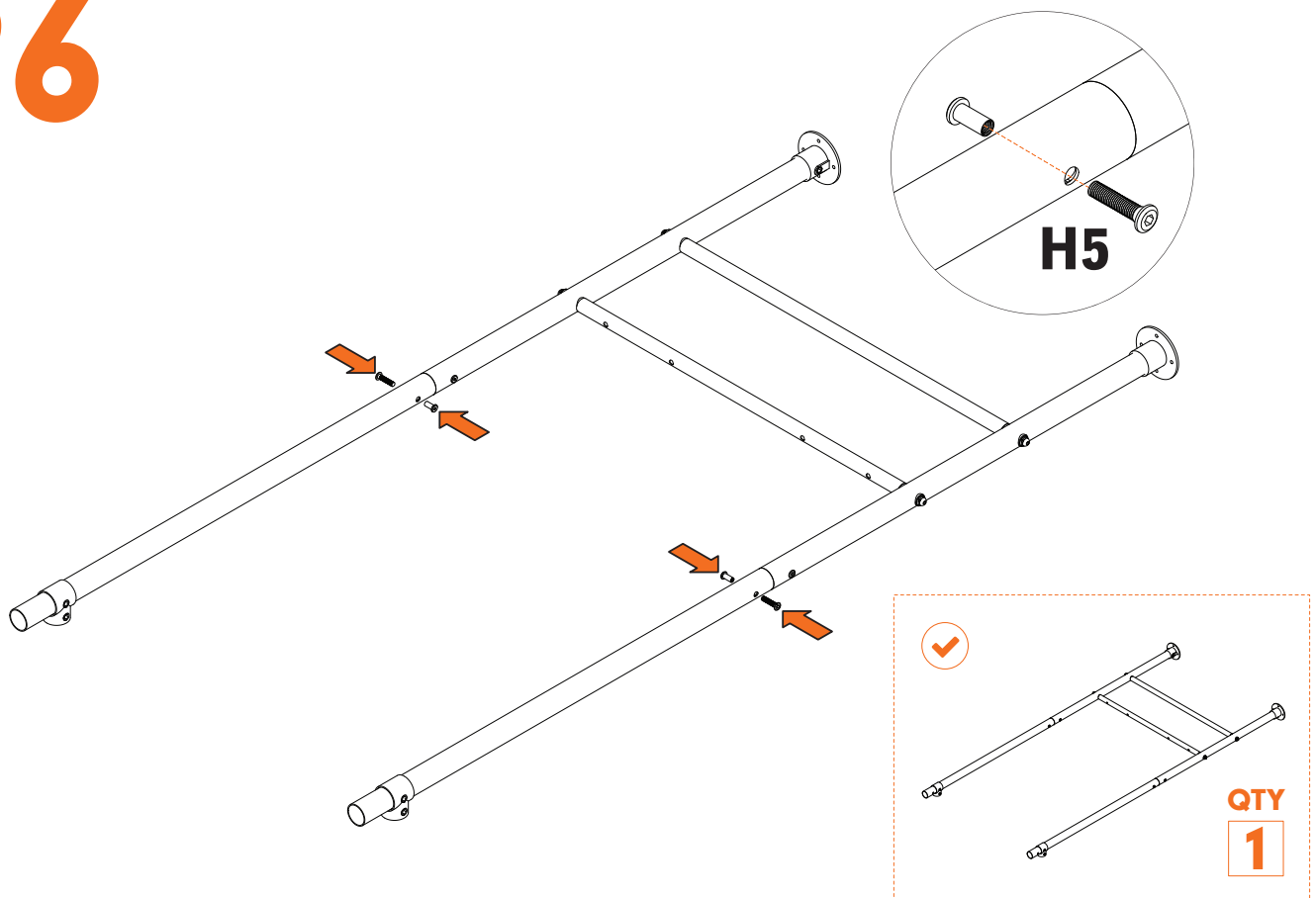

YOU HAVE A CARGO NET? SKIP TO STEP 34



# 27

## FRAME ASSEMBLY

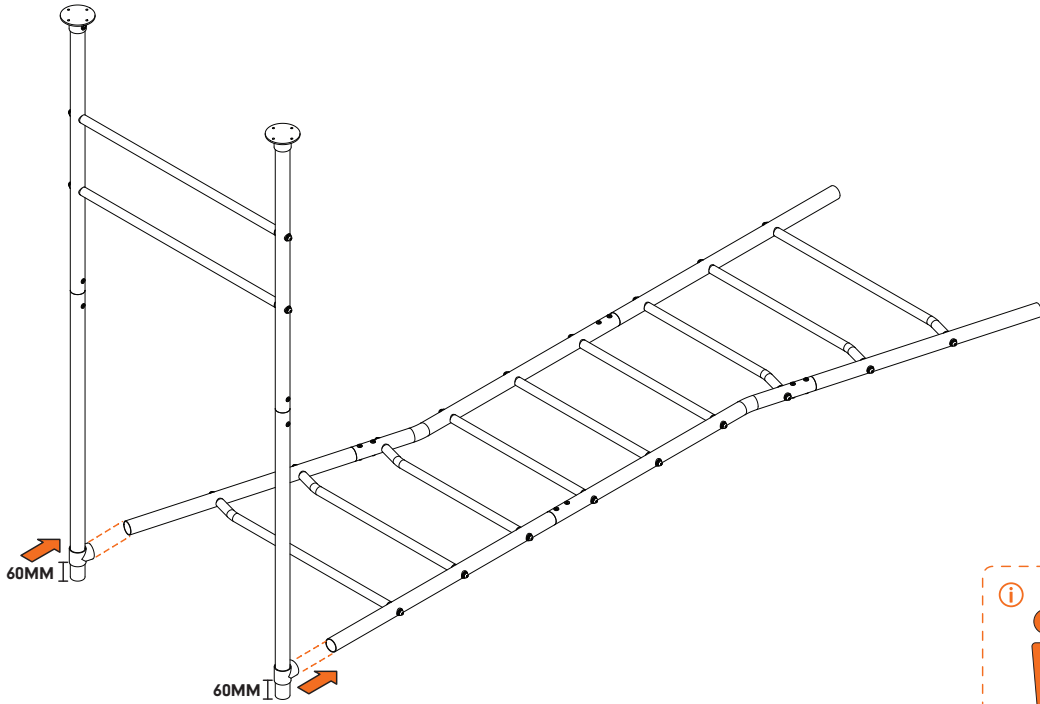

# 28

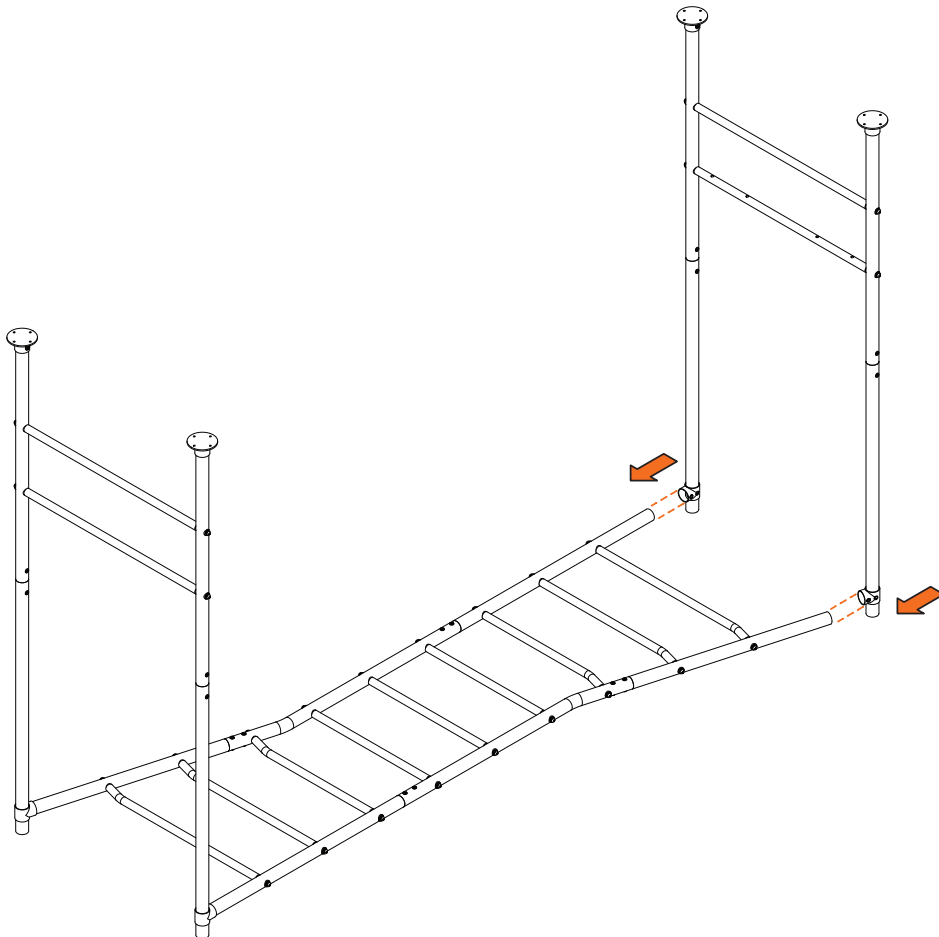

# 29

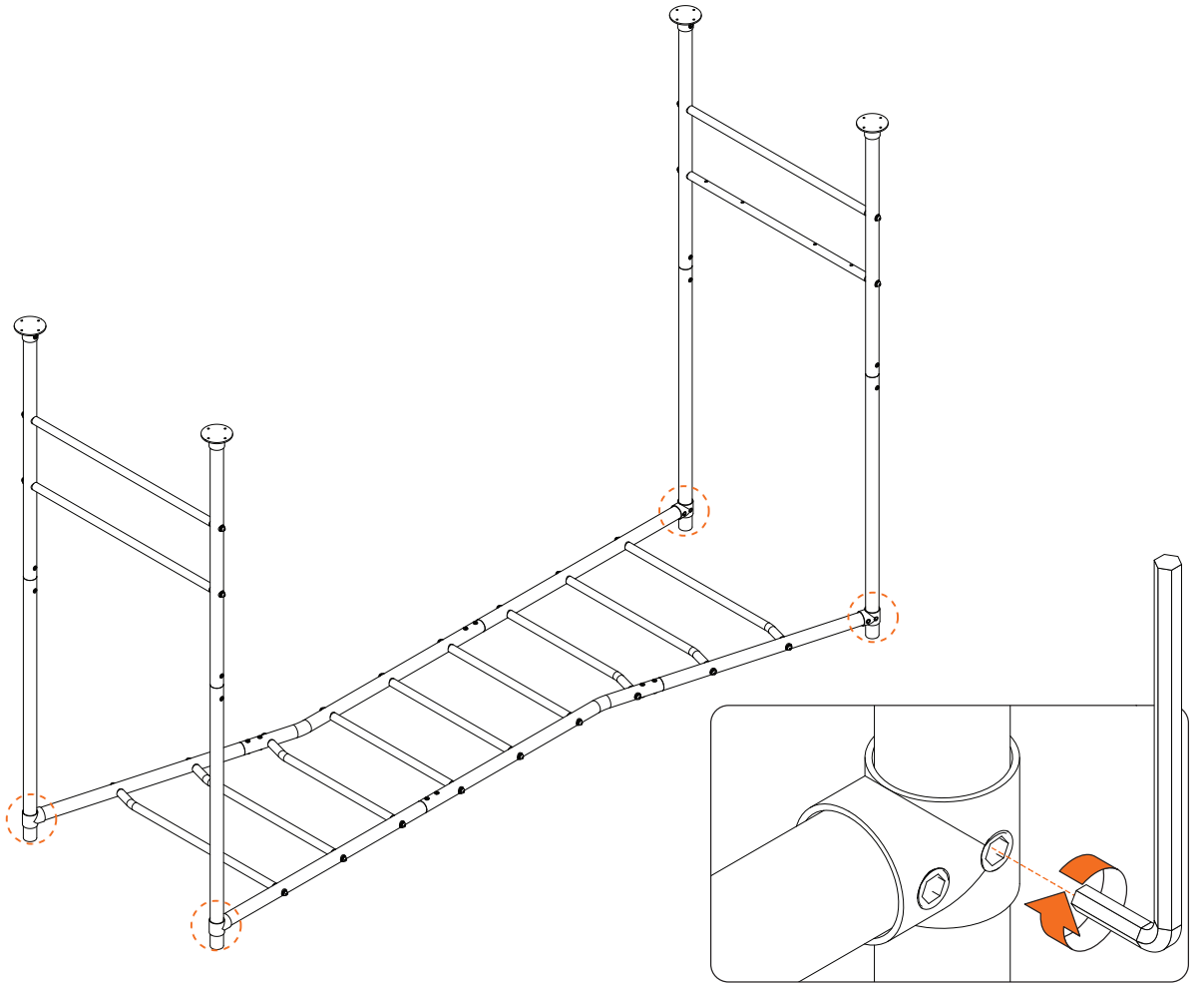

# 30

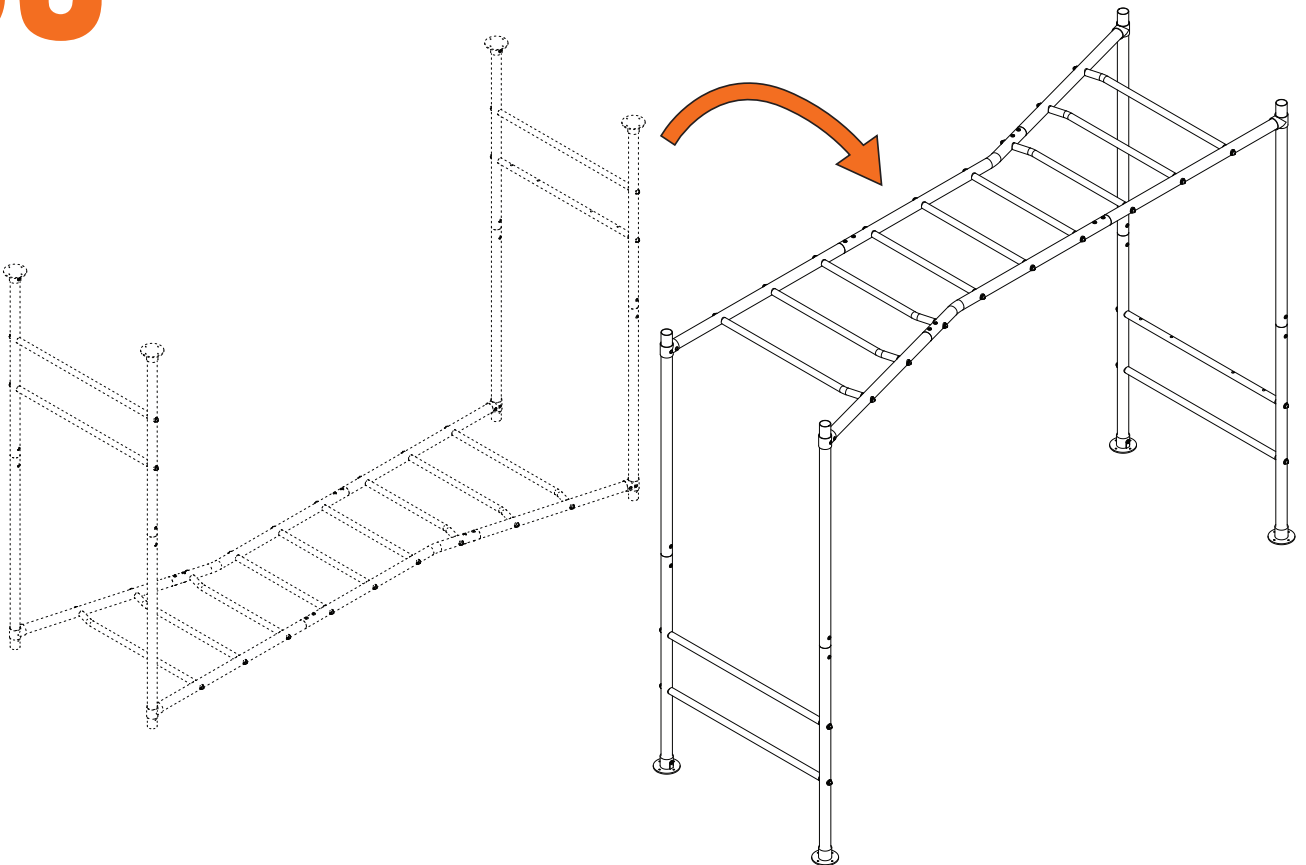

# 31

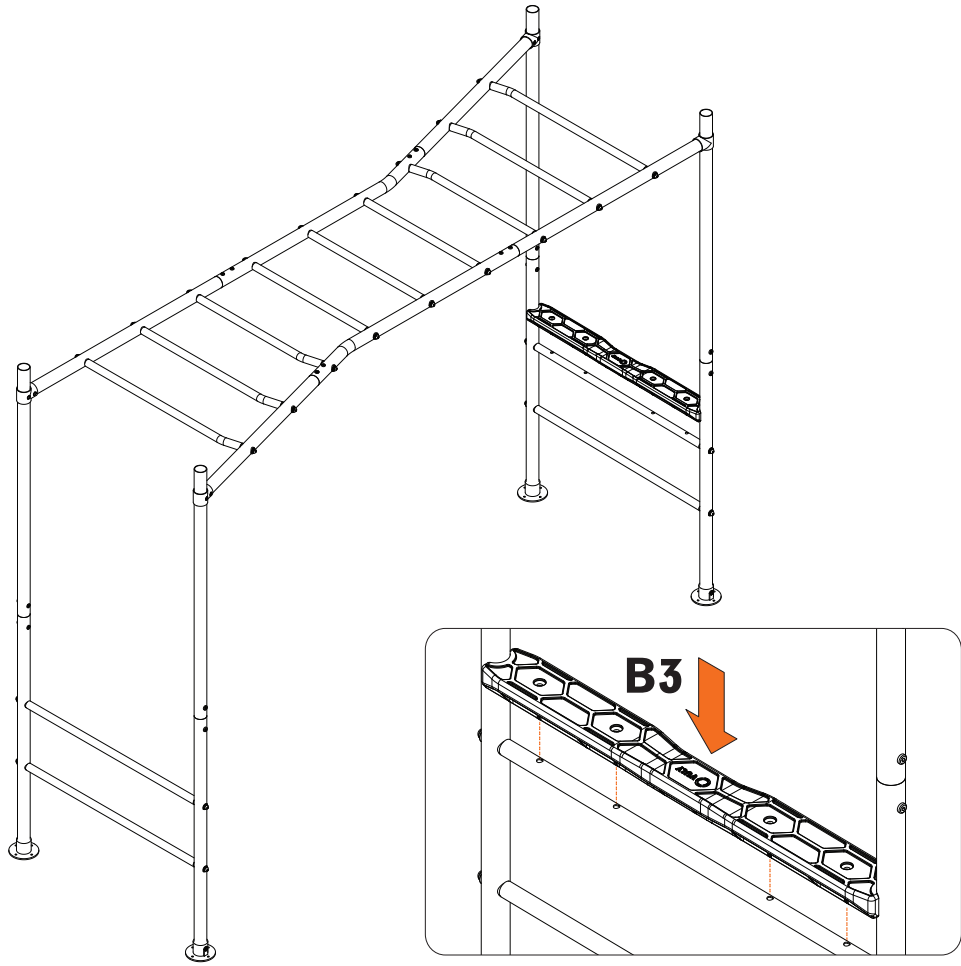

# 32

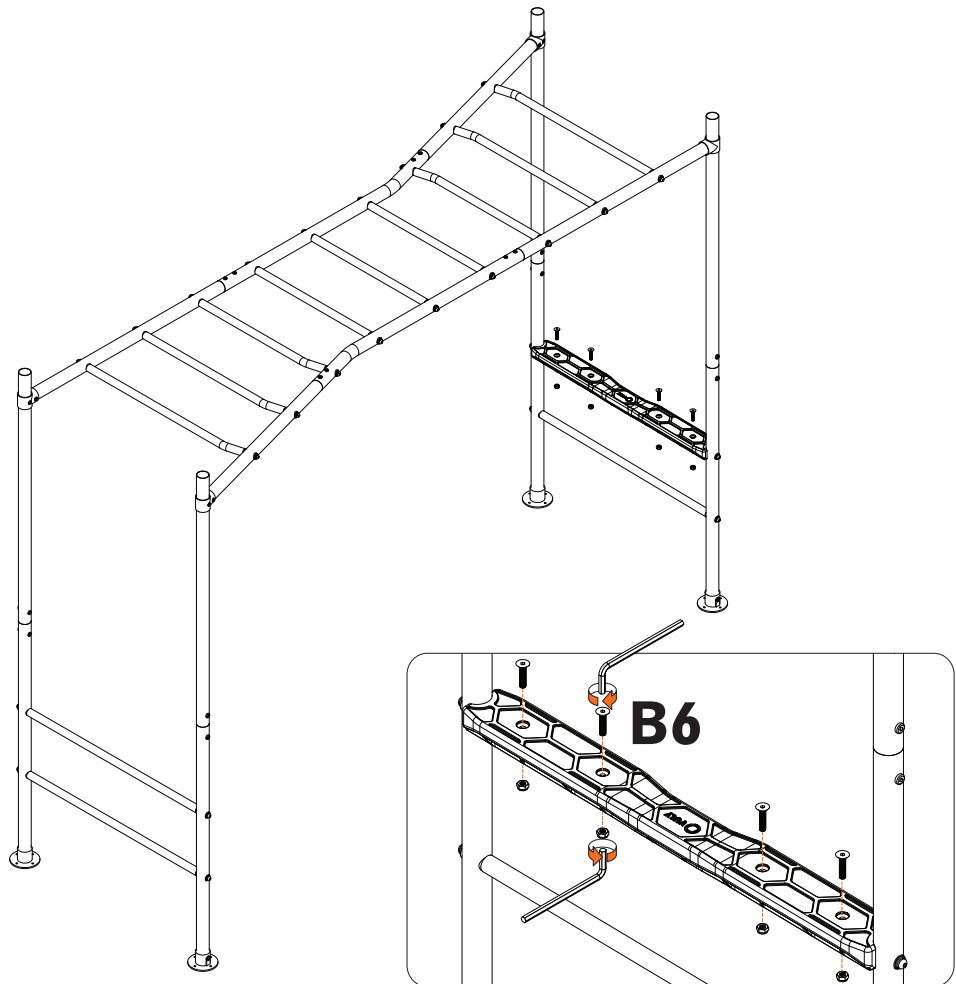

# 33

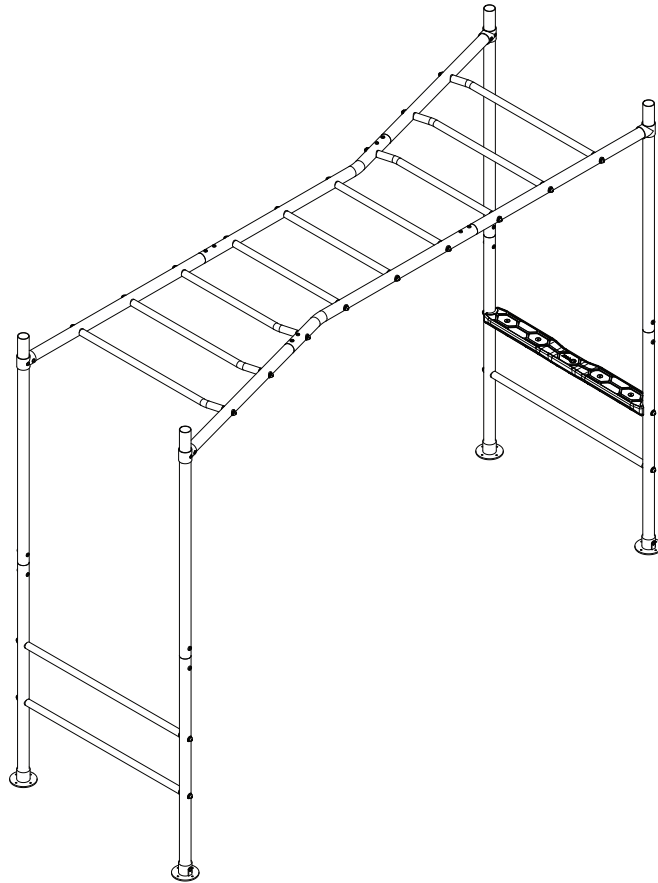

NO CARGO NET? SKIP TO STEP 42



# 34

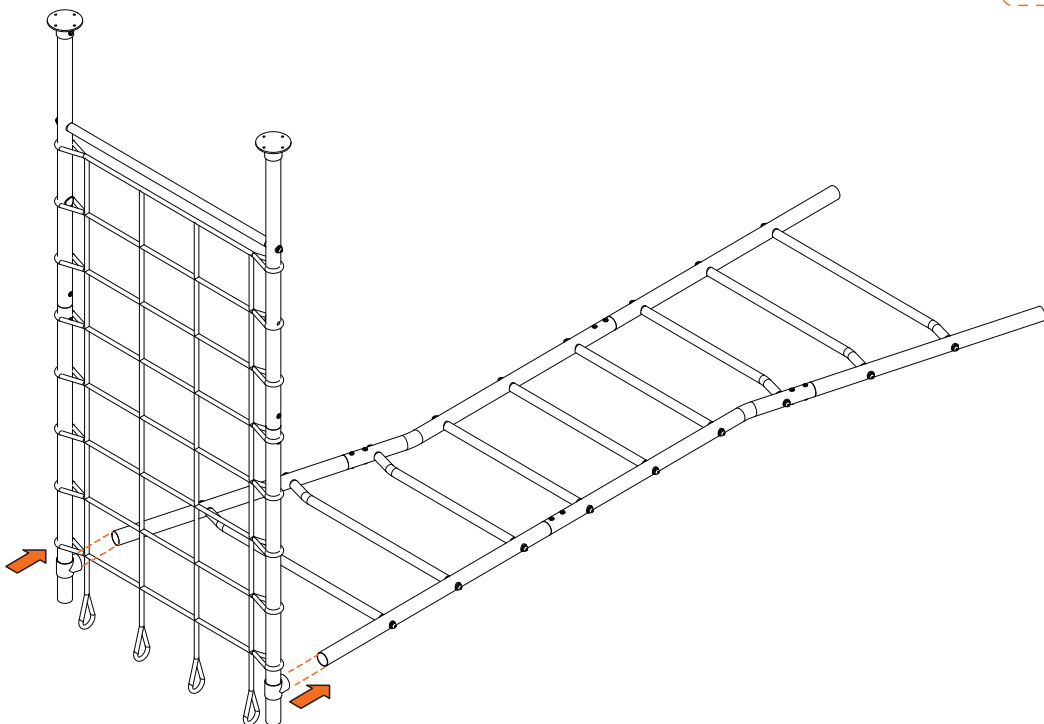
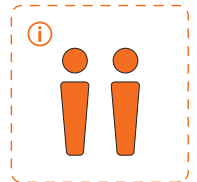

# 35

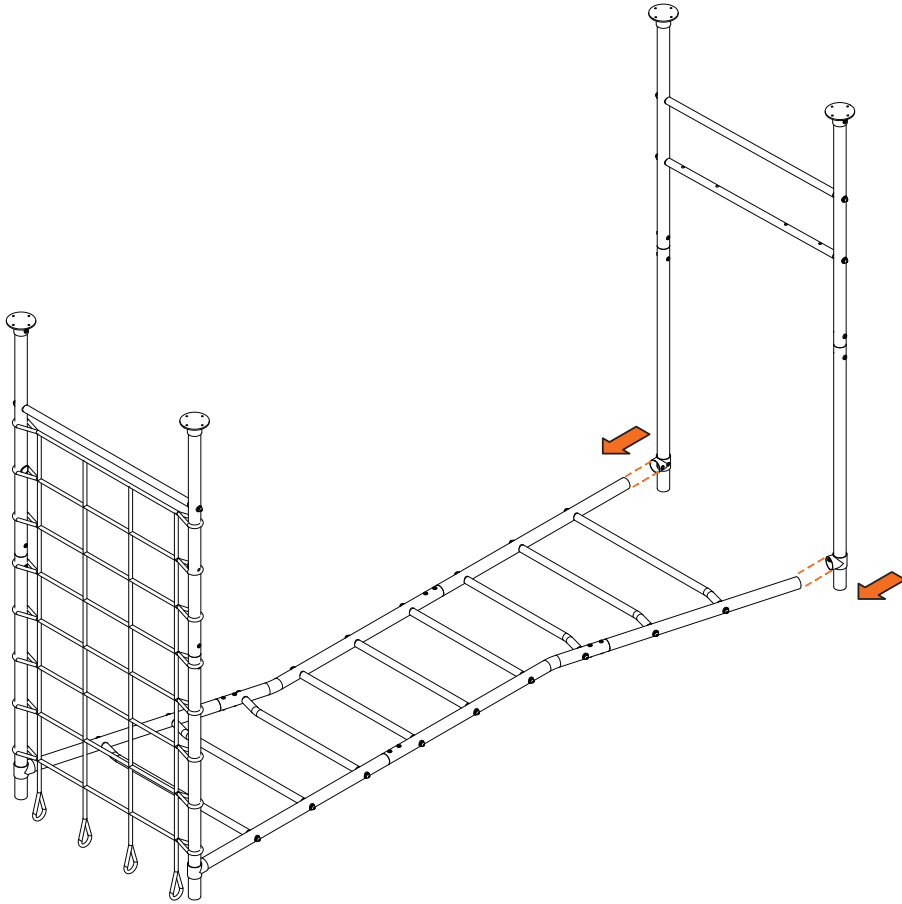

# 36

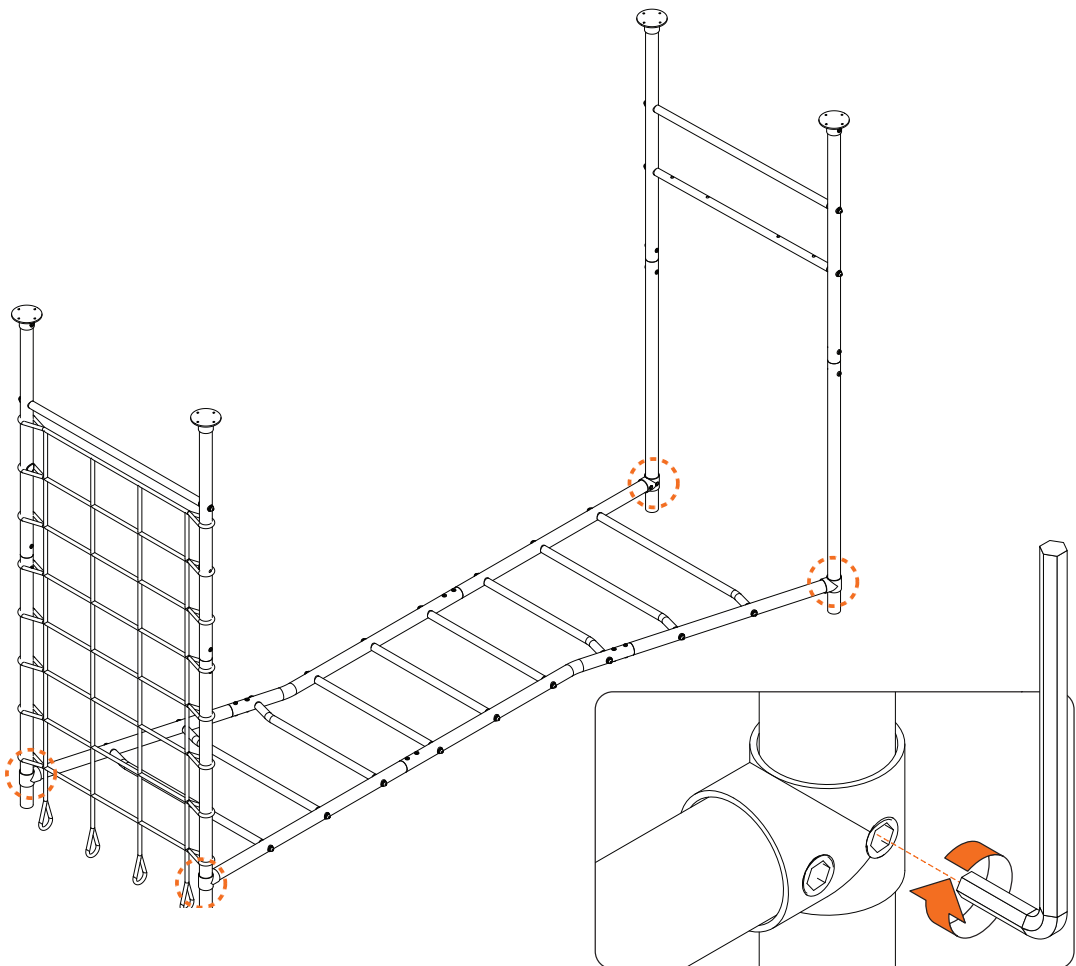

# 37

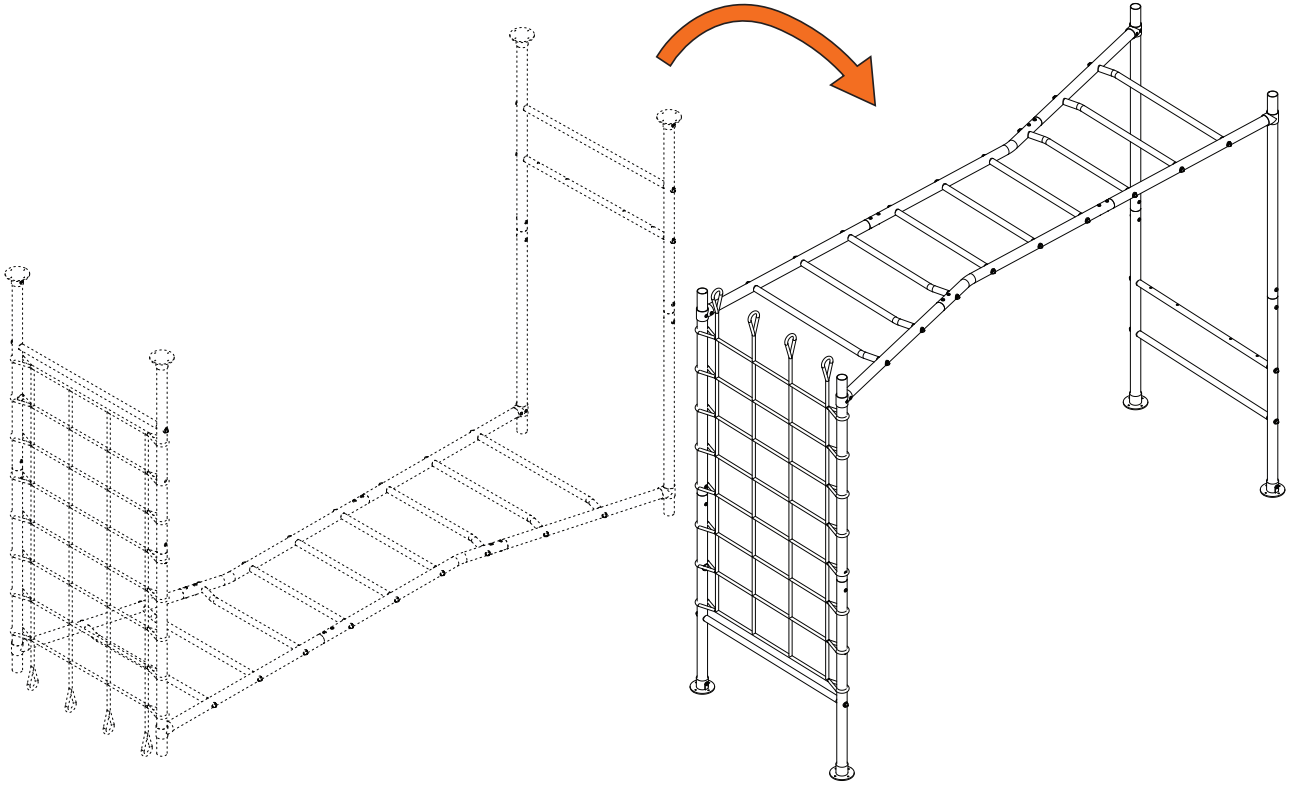

# 38

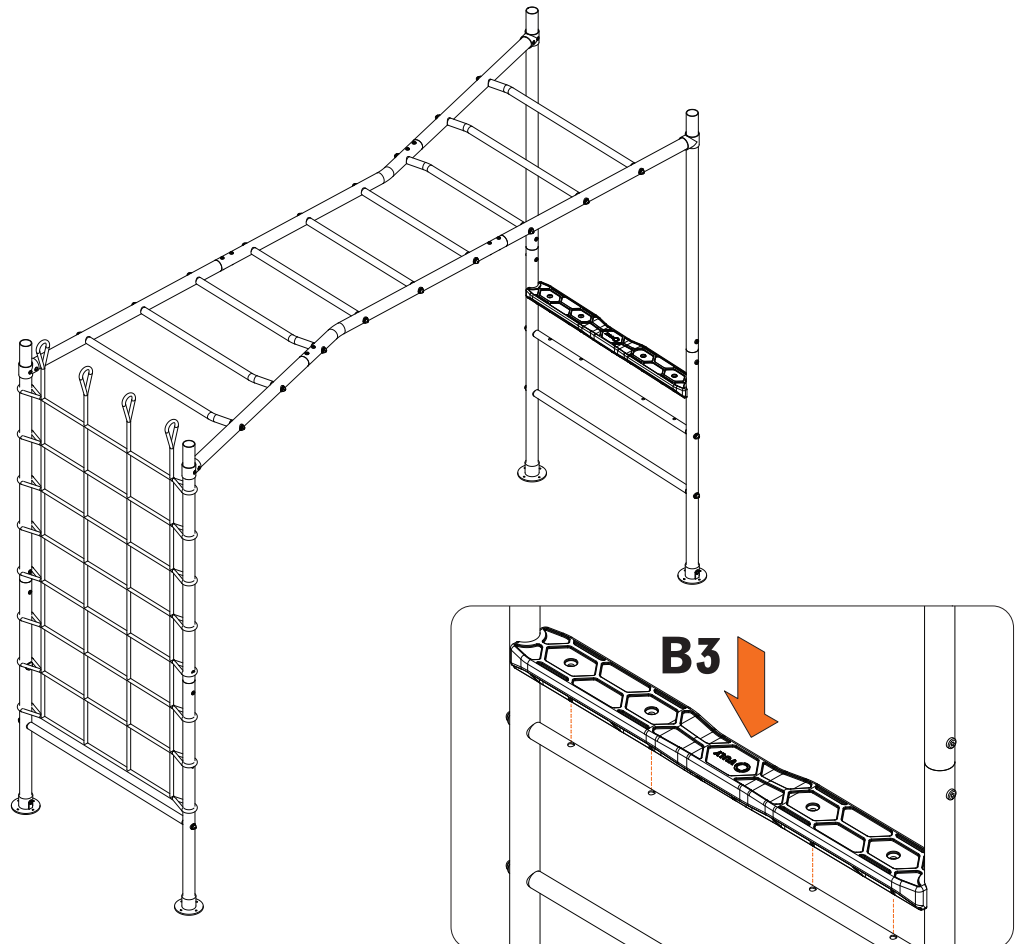

# 39

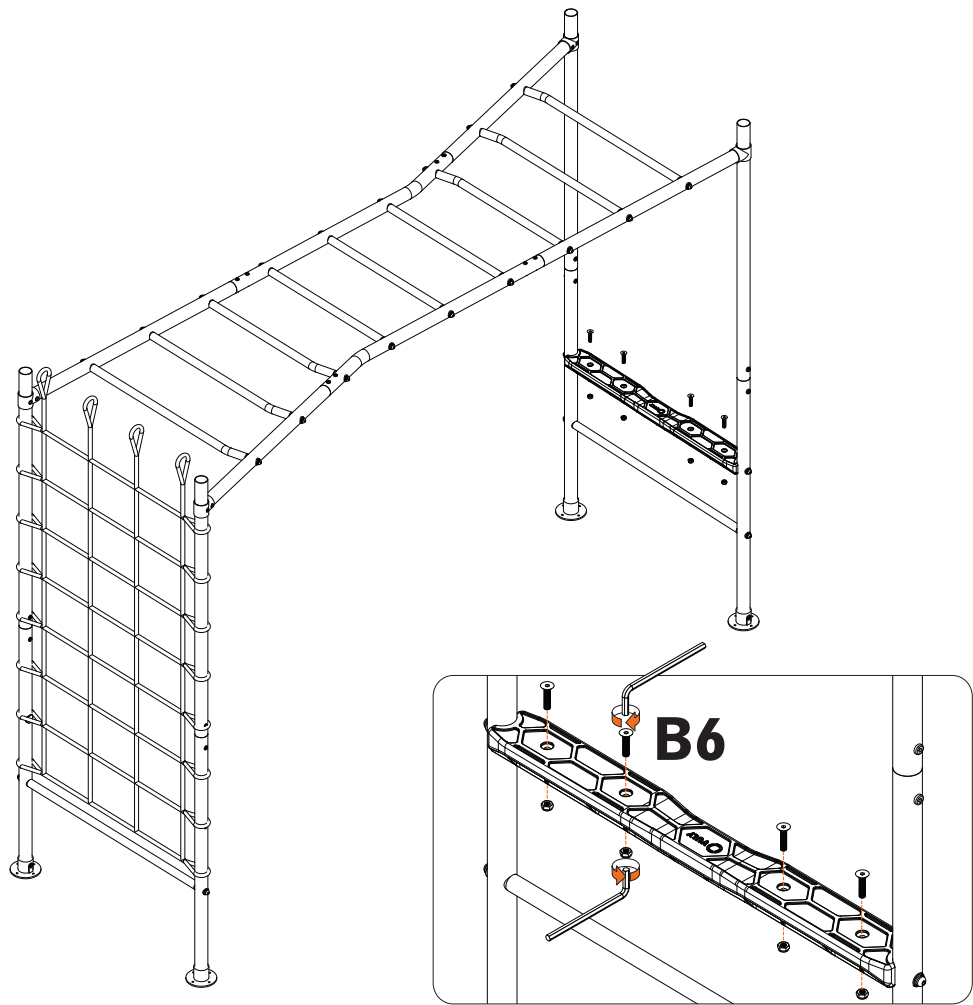

# 40

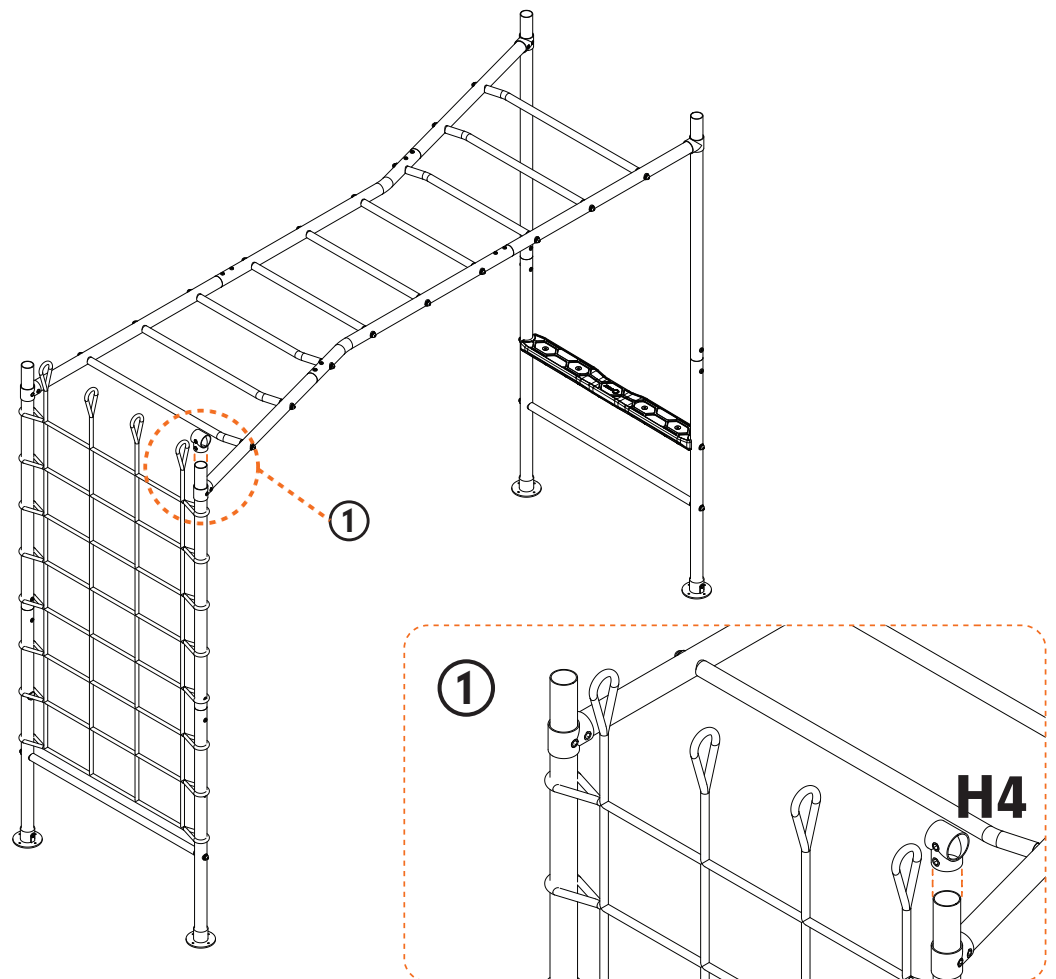

# 41

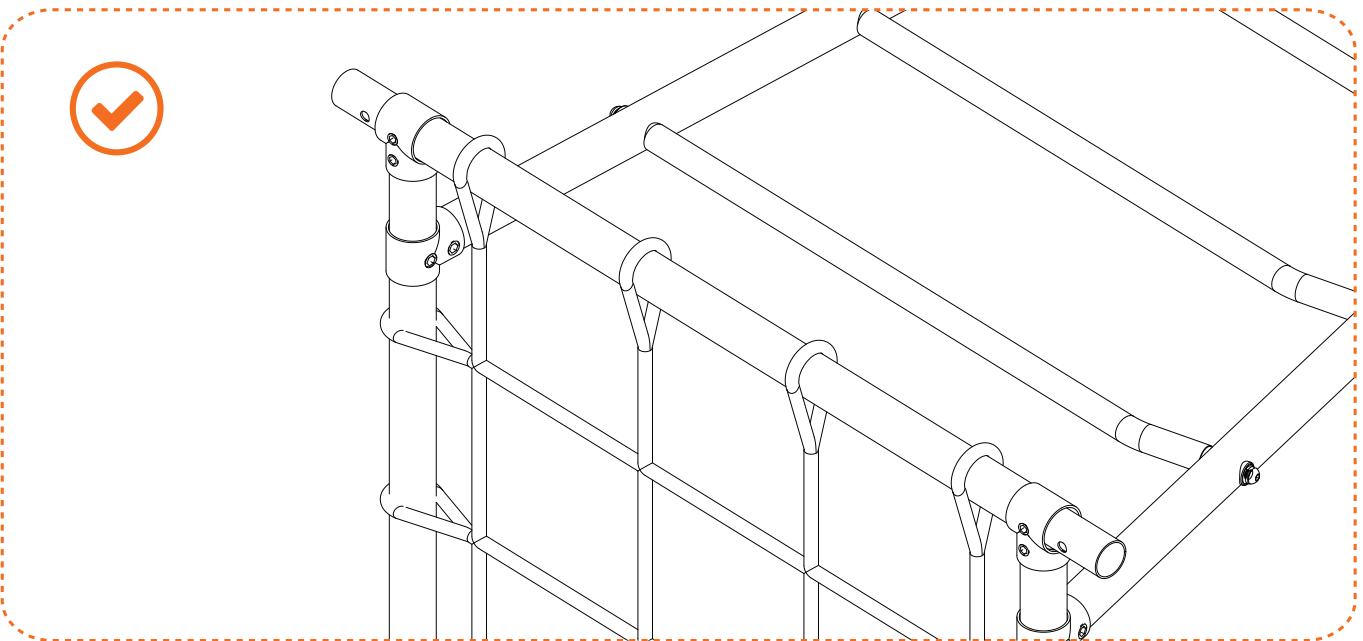
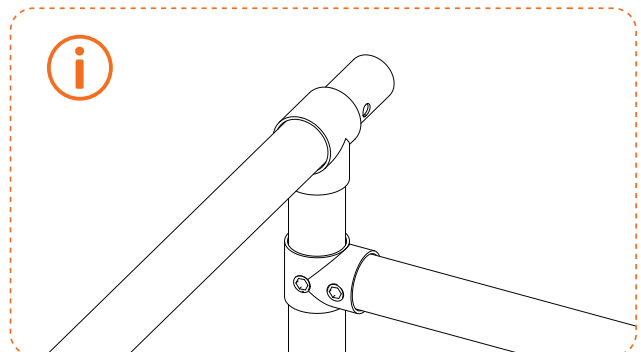
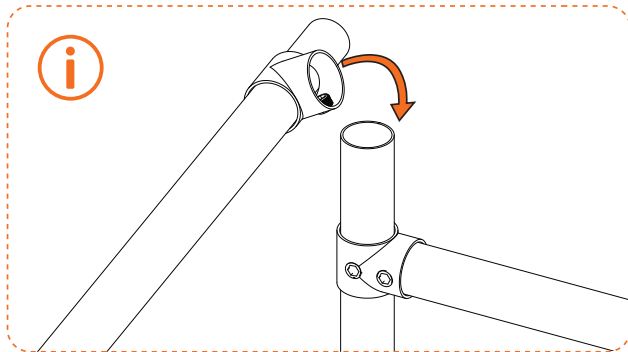
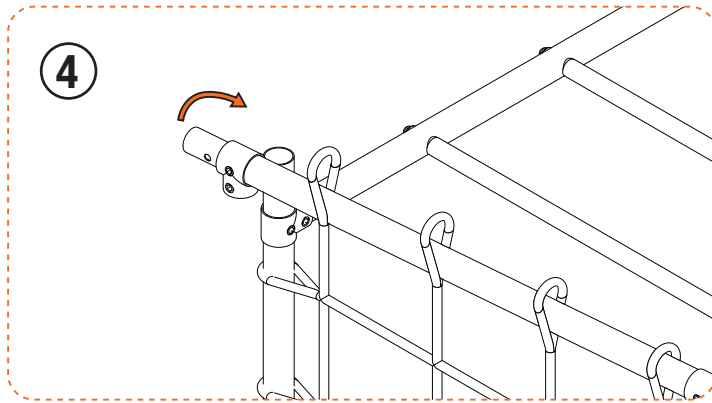
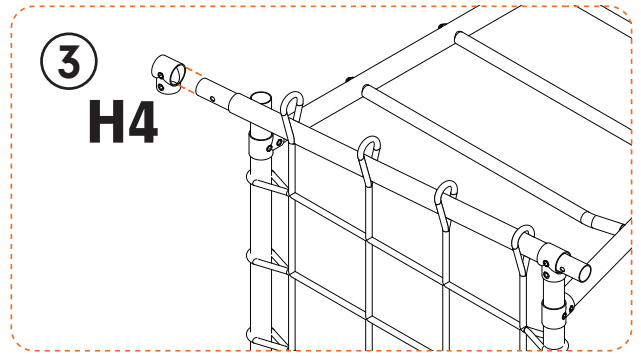
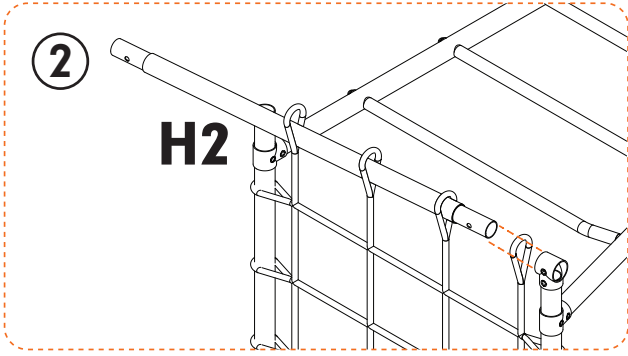

 **SKIP TO STEP 44** 

# 42

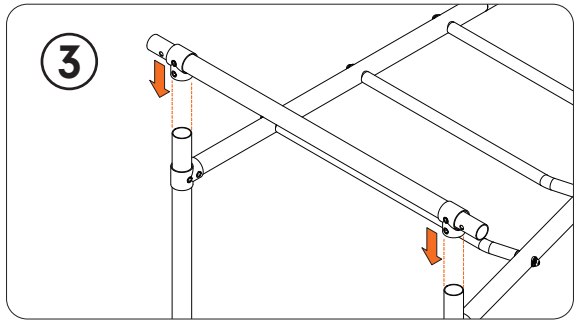
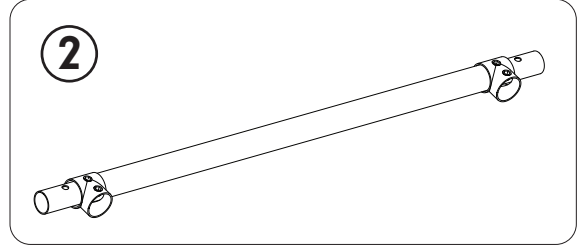
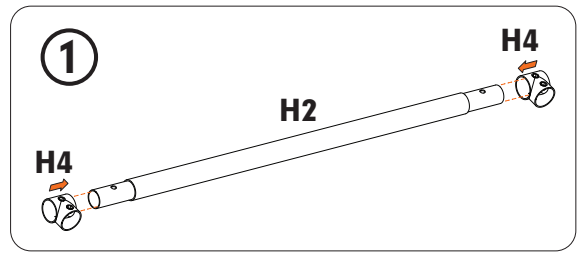
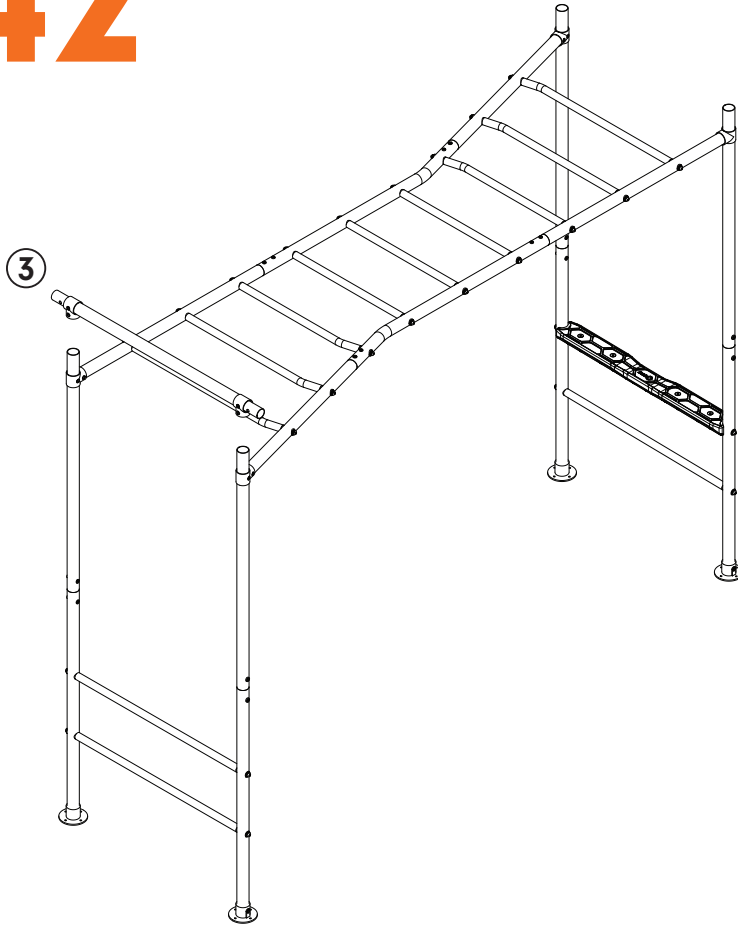

# 43

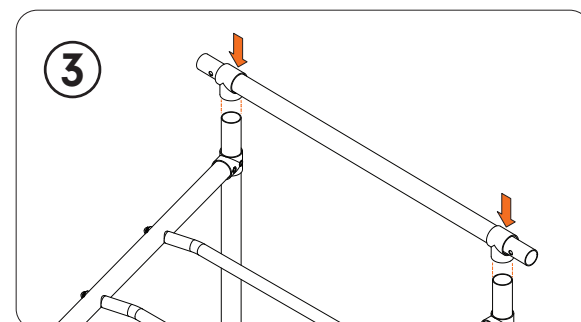
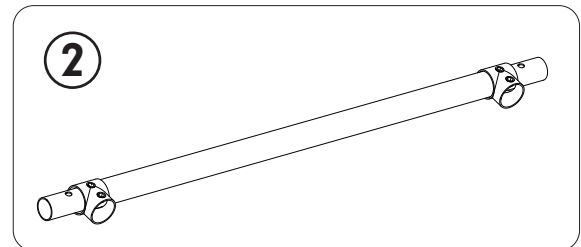
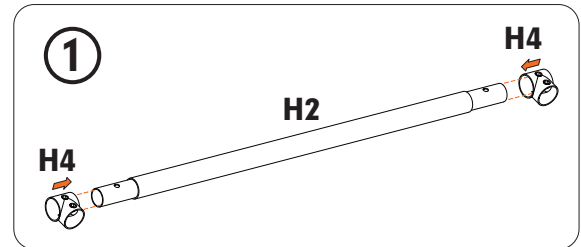
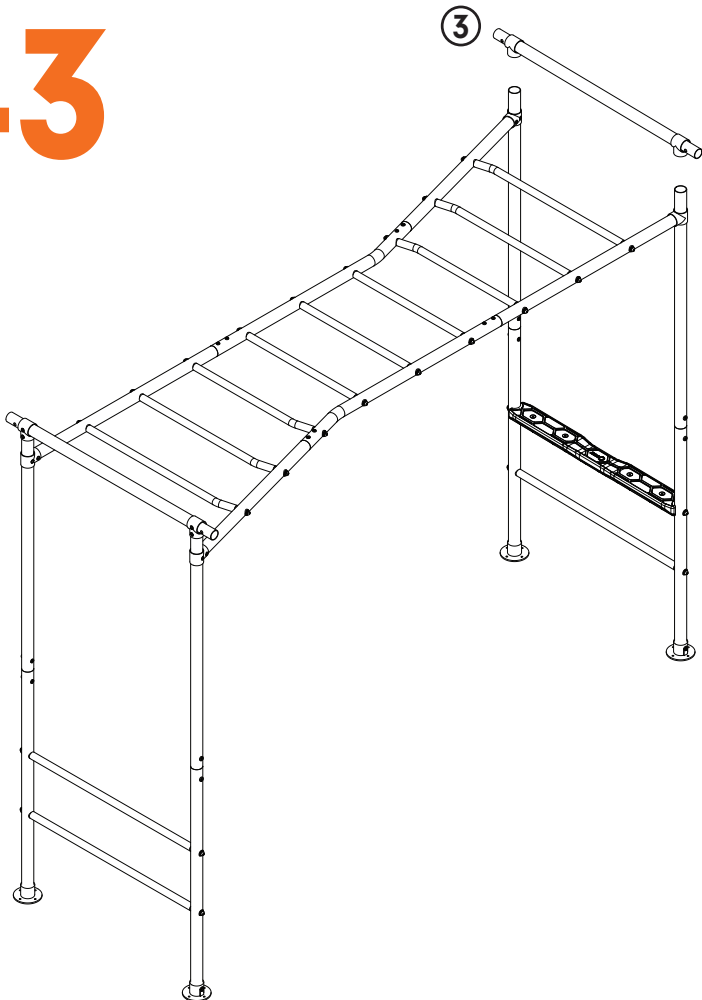

# 44

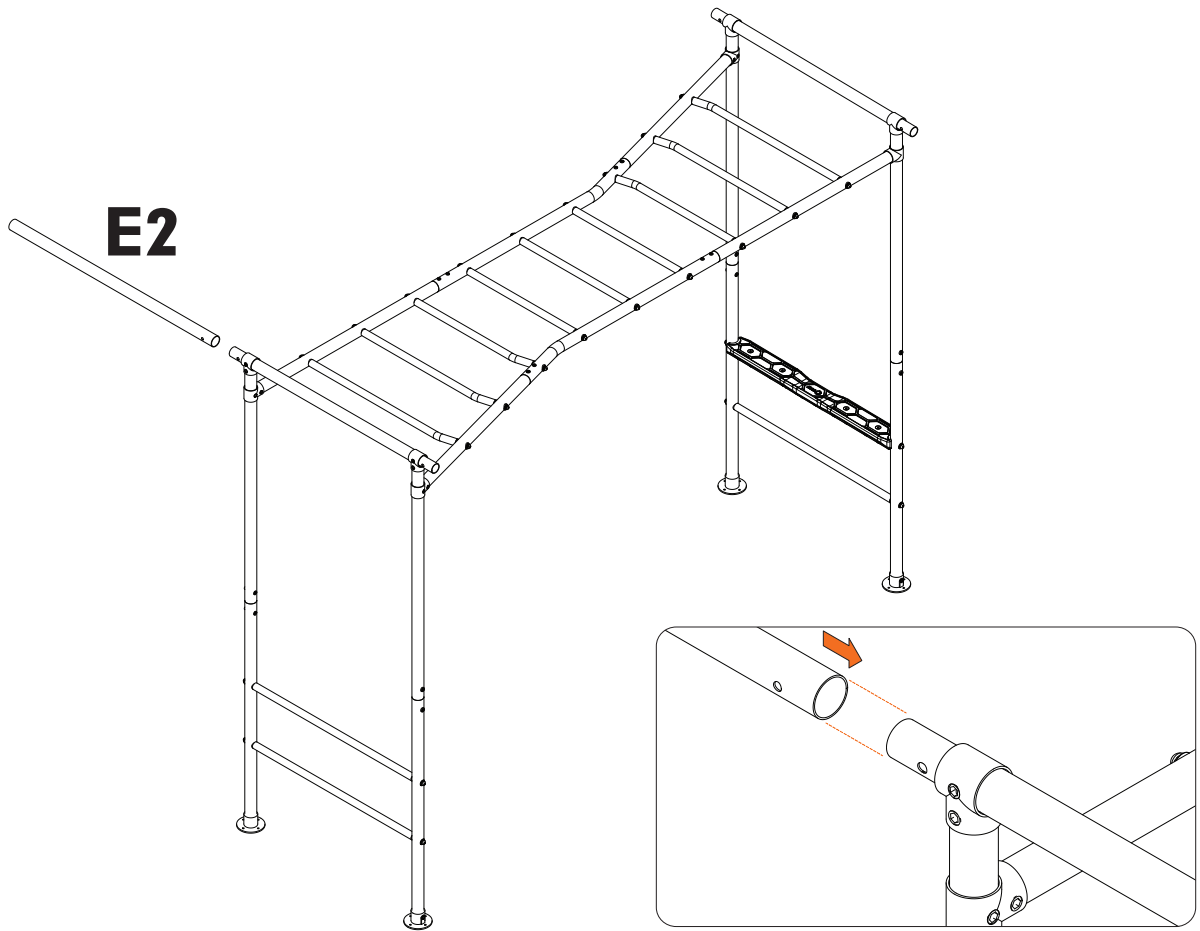

**WARNING:** Ensure correct parts are installed and E2 is longer than E4.



# 45

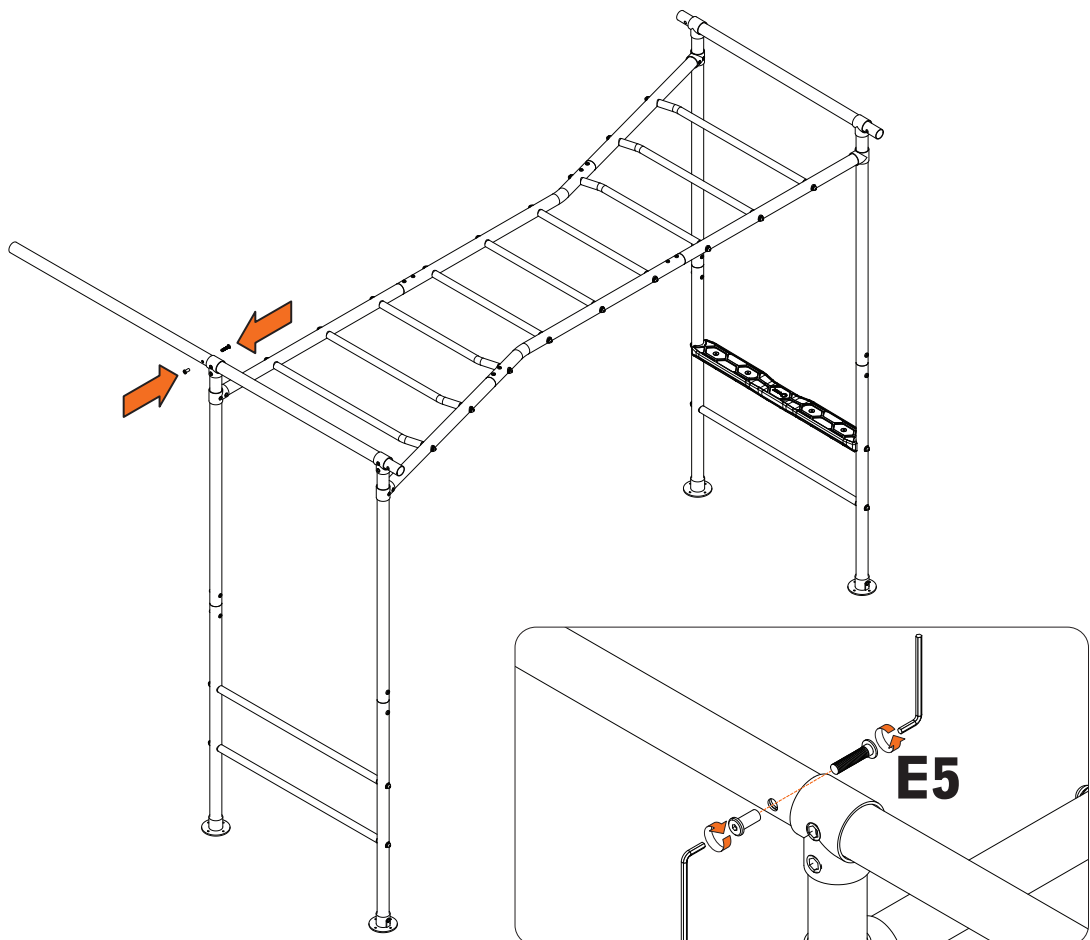

# 46

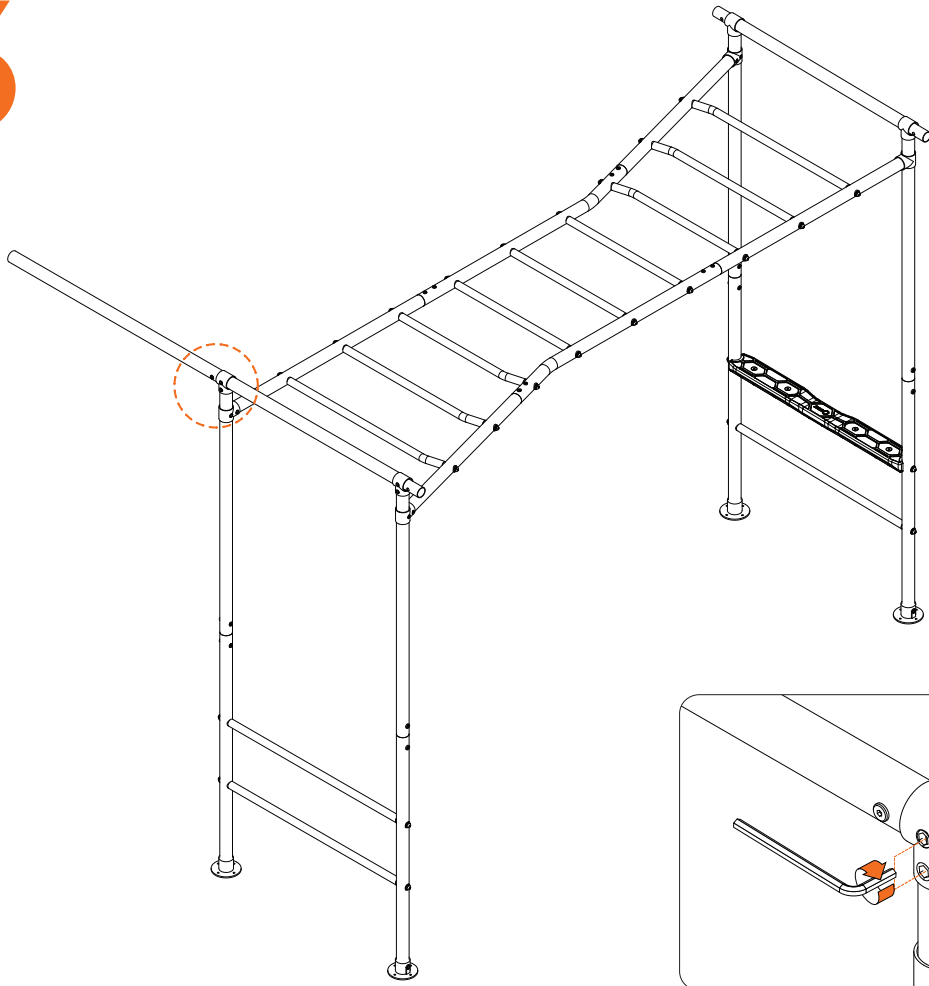

# 47

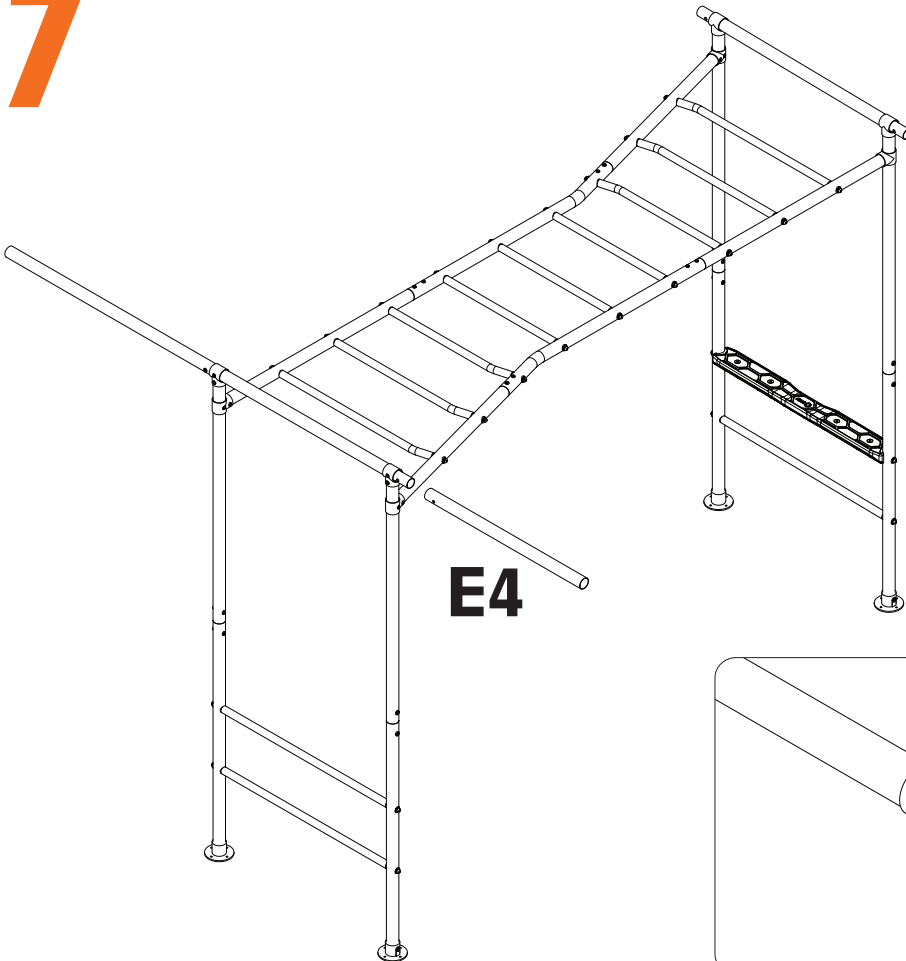

**E4**

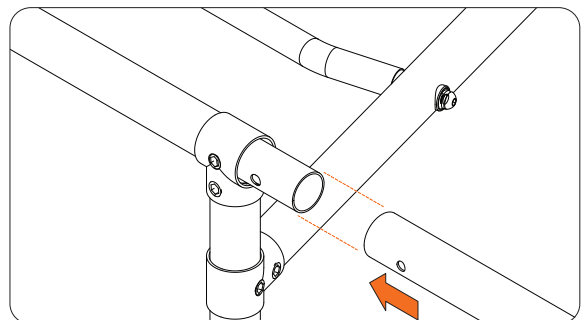

# 48

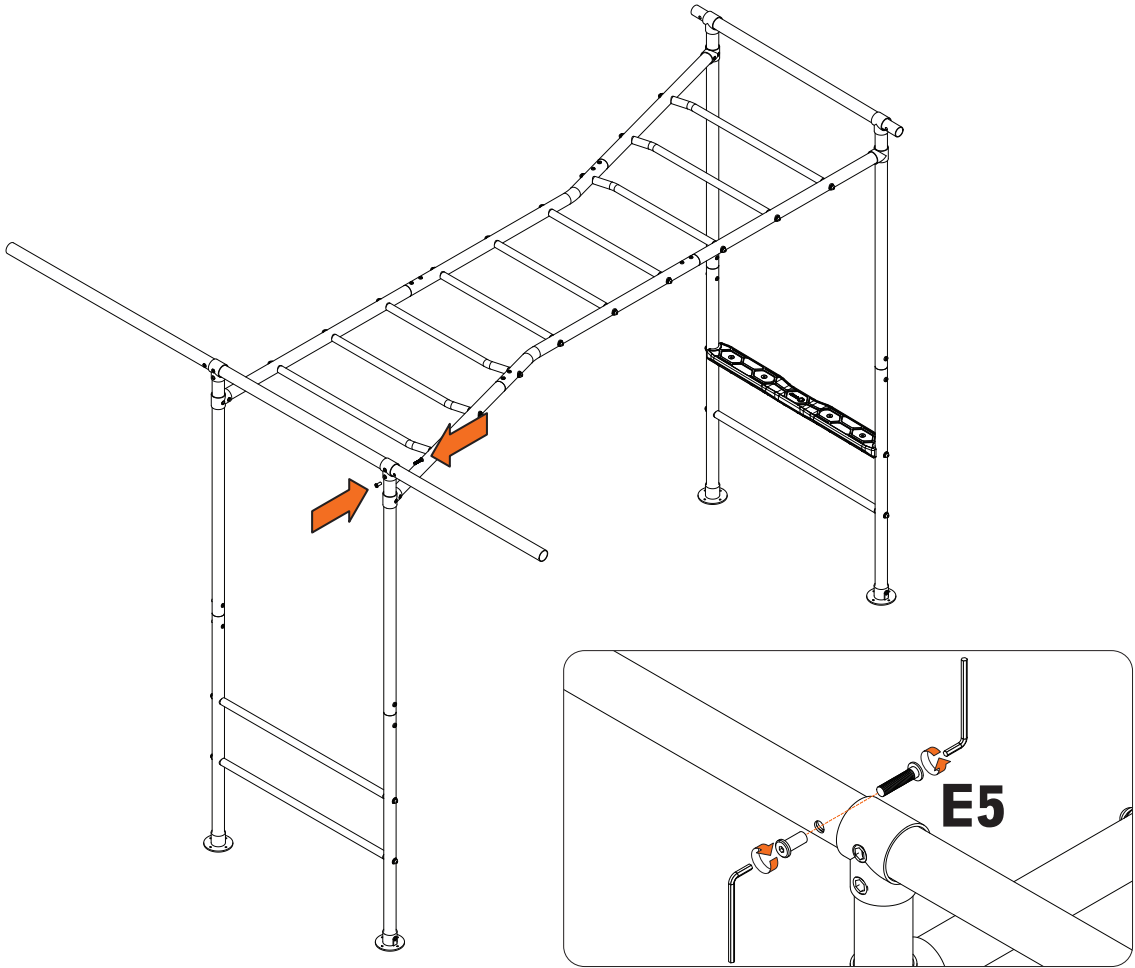

# 49

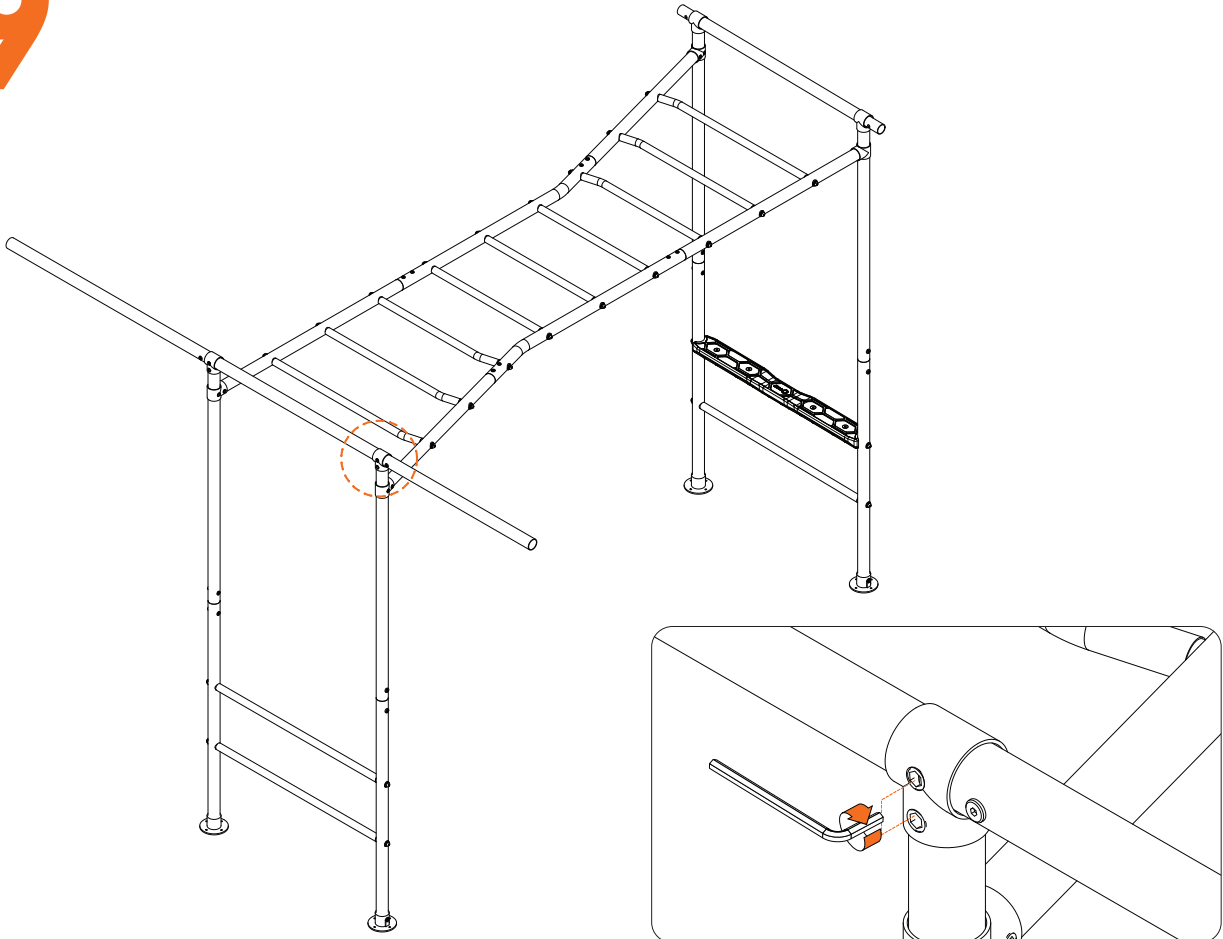

# 50

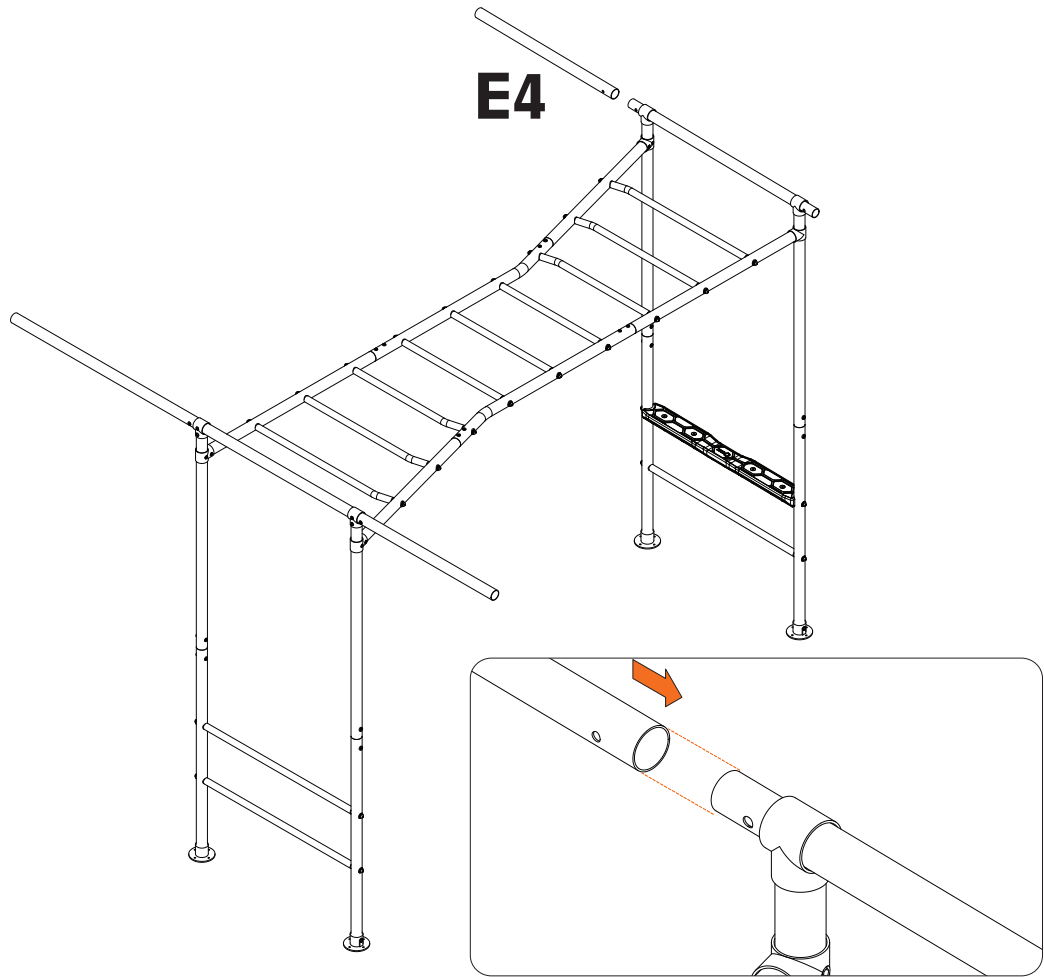

# 51

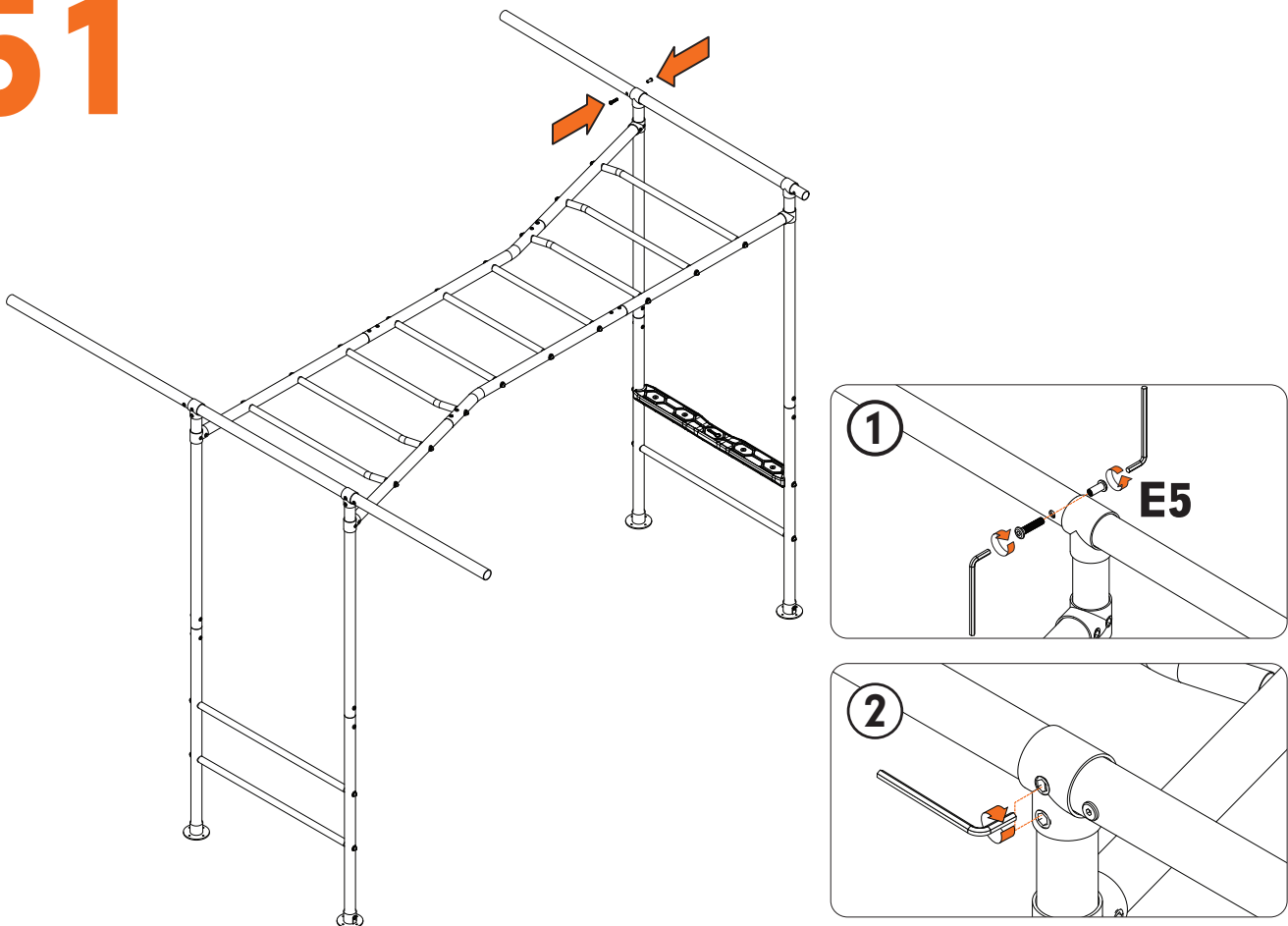

# 52

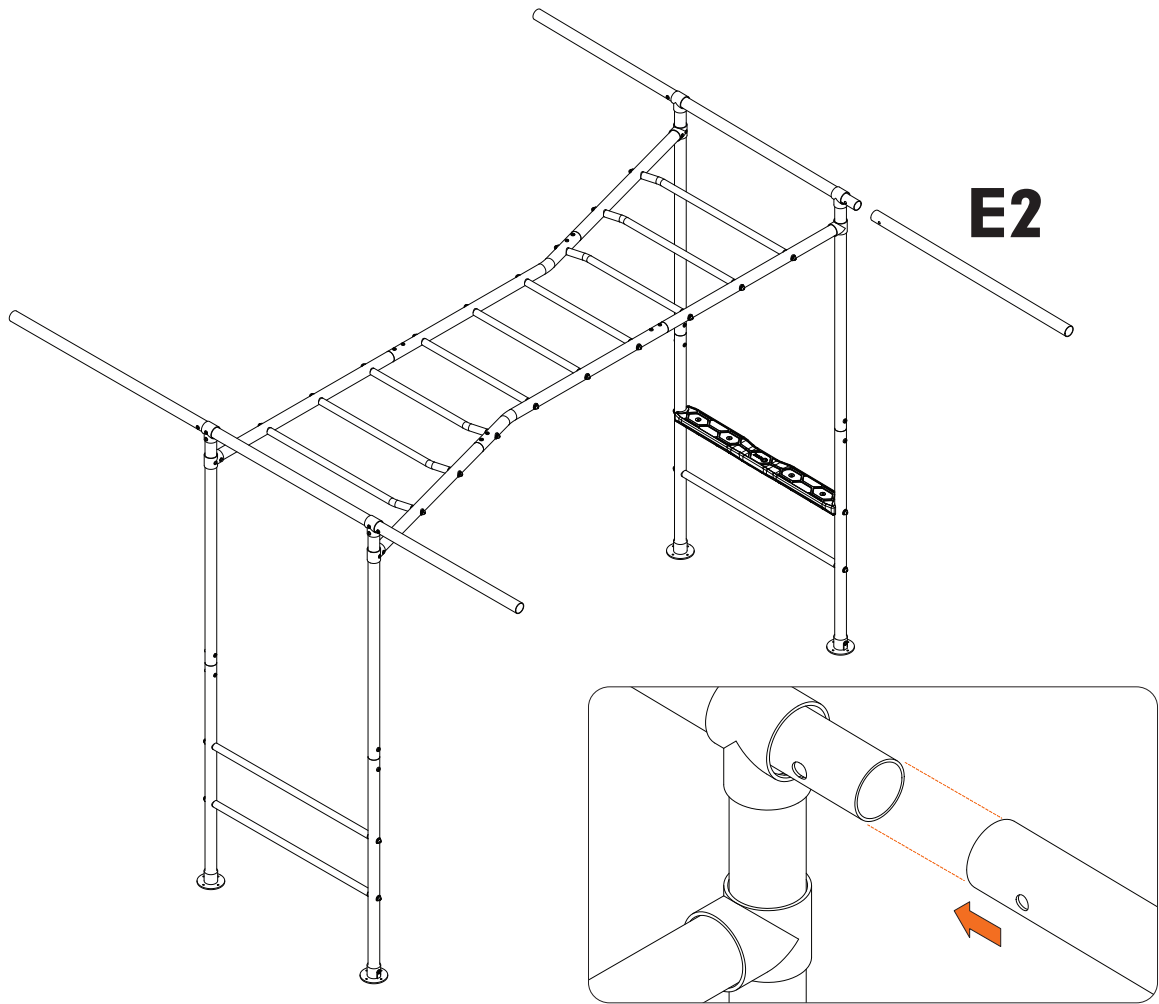

# 53

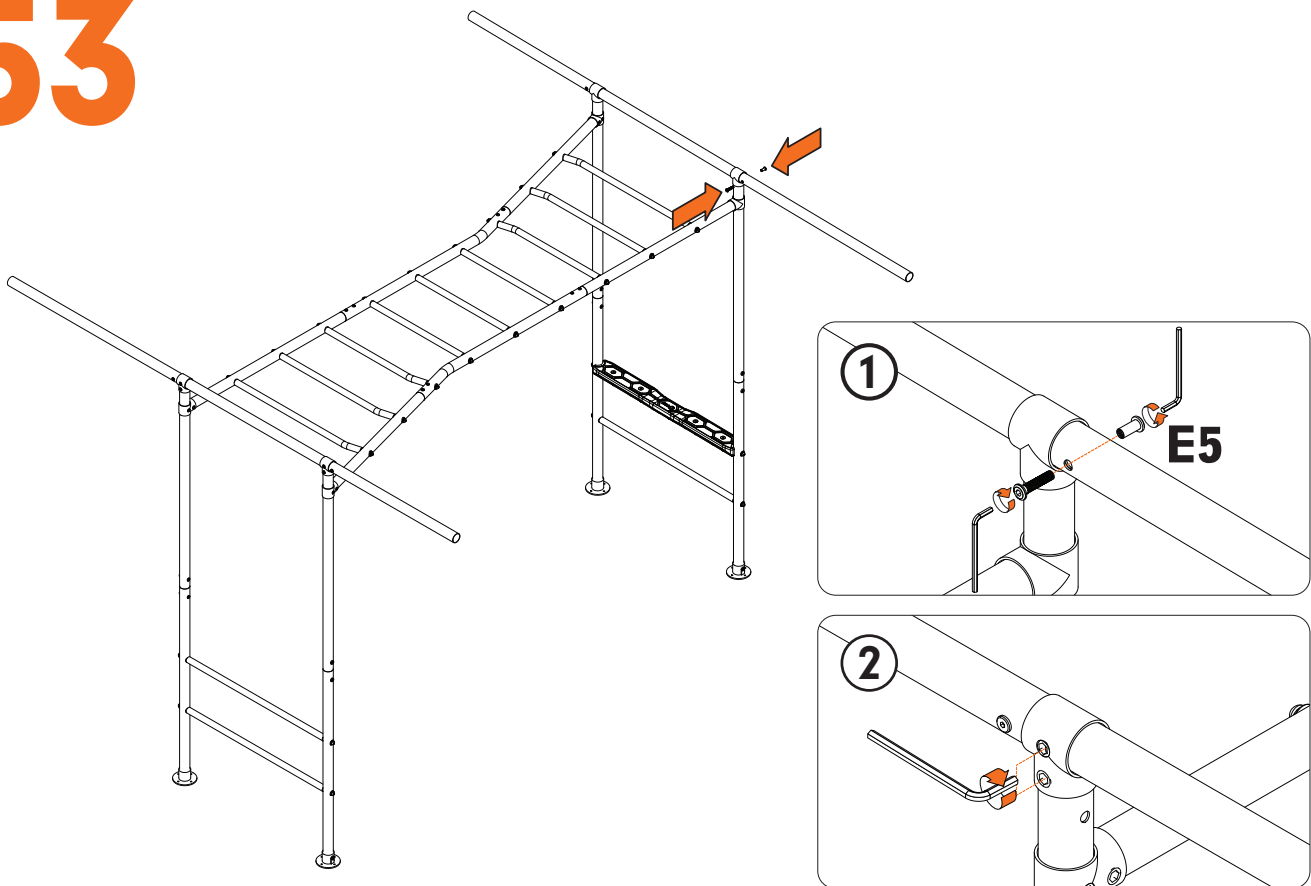

NO FLYING FOX? SKIP TO STEP 56





FOR VERSION 1

①

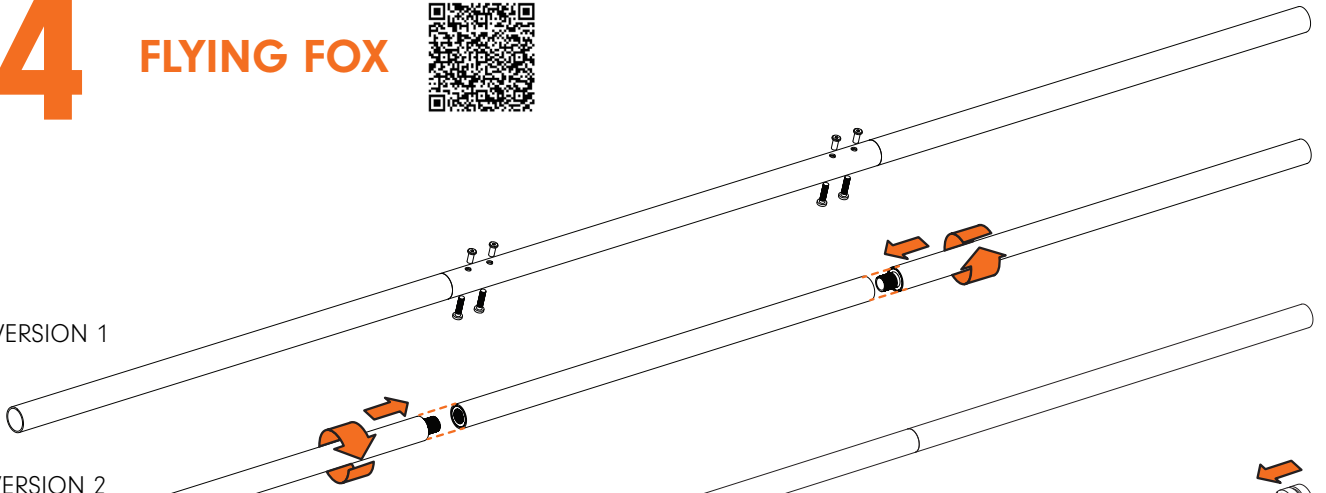

FOR VERSION 2

①

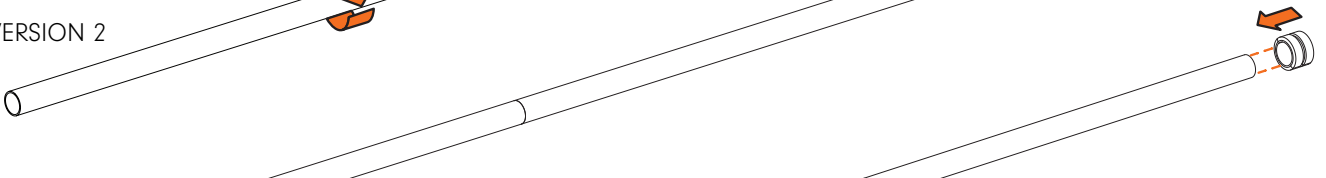

②

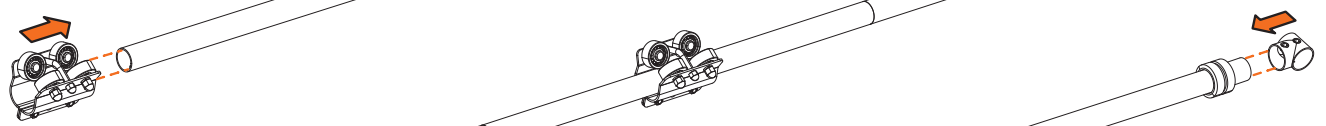

③

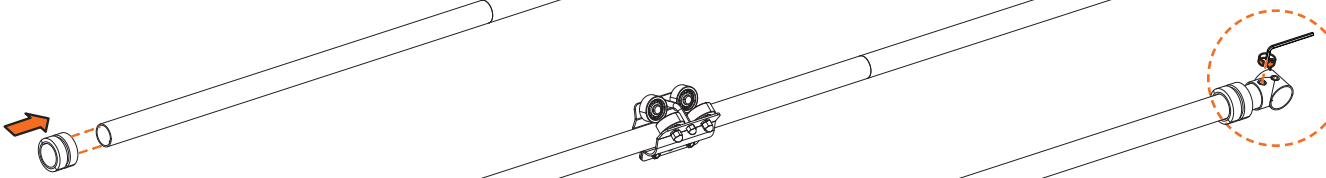

④

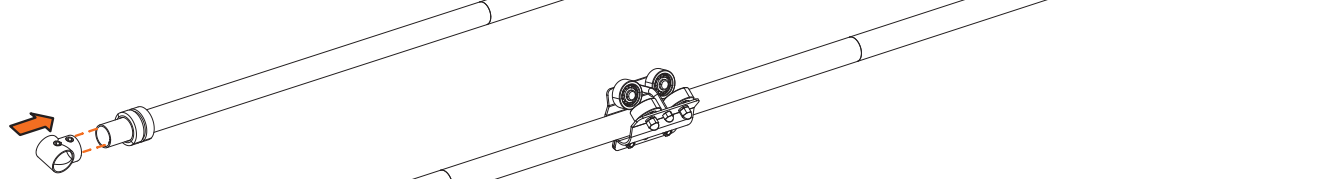

⑤



**STEP 5 WARNING:** ENSURE THE GRAB SCREW IS TIGHTENED BEFORE PROCEEDING TO THE NEXT STEP.



⑥

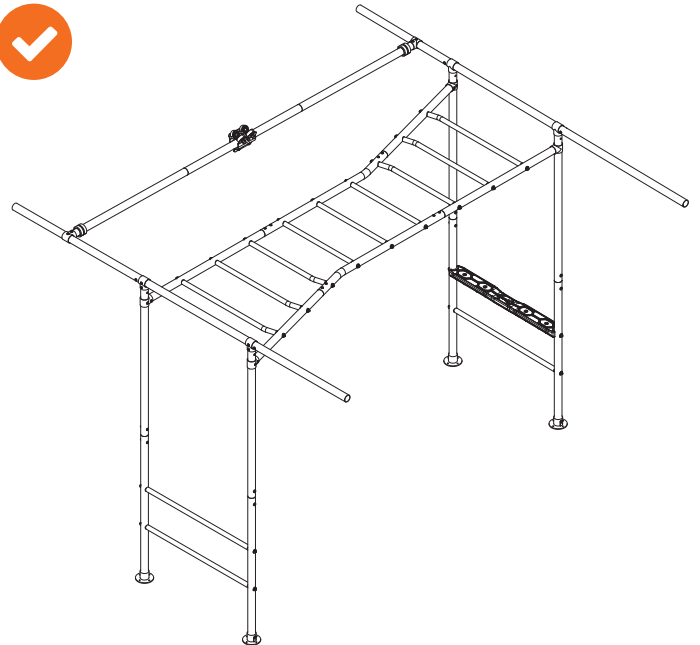
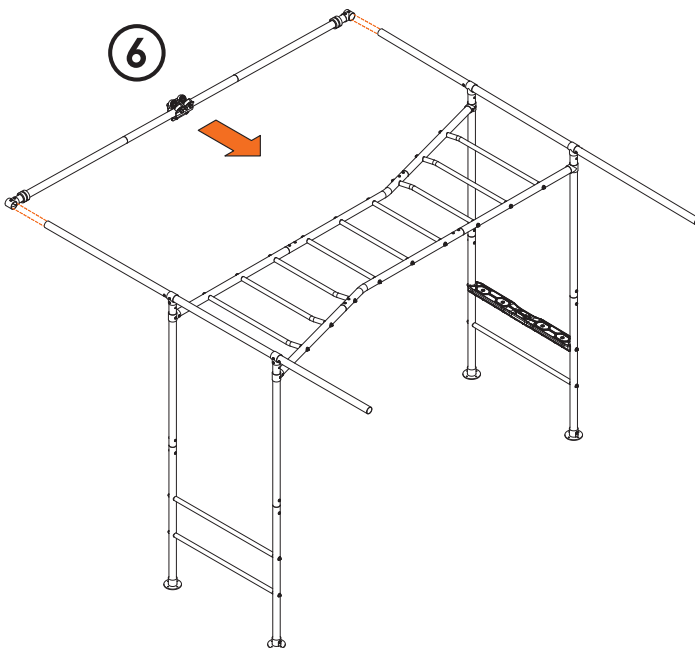

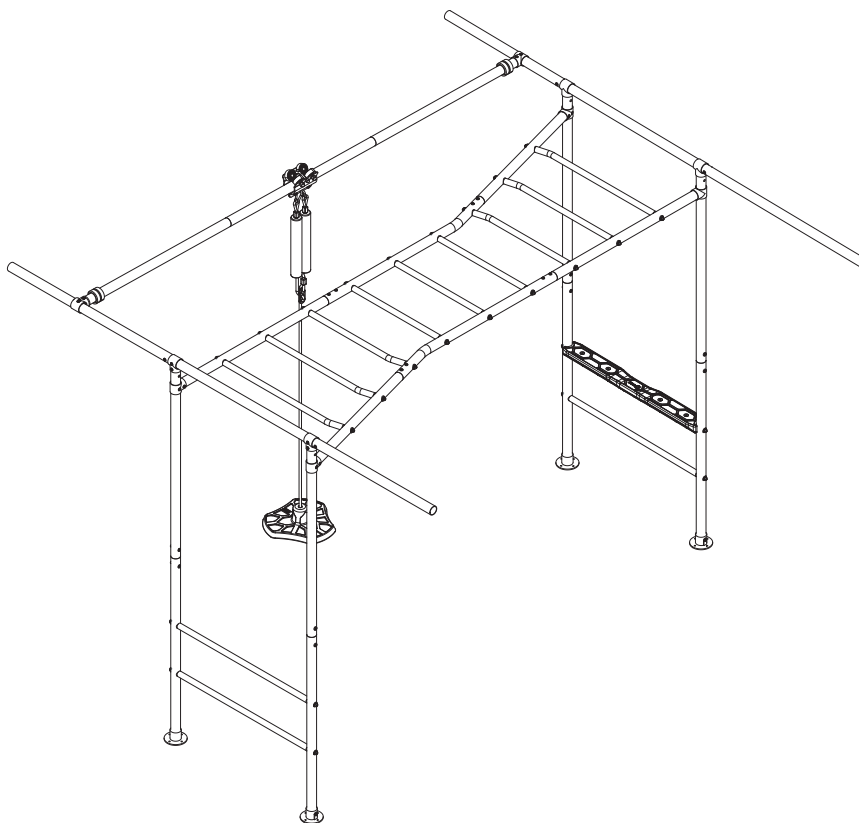
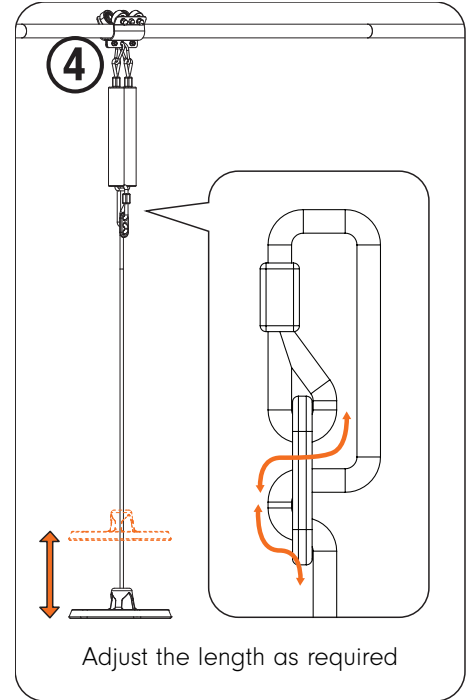
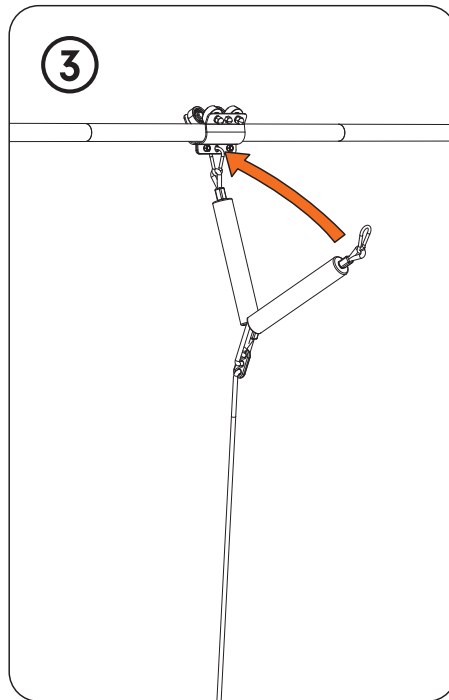
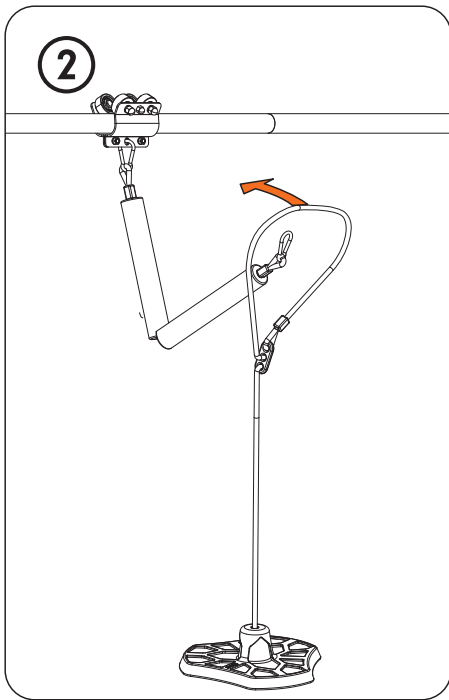
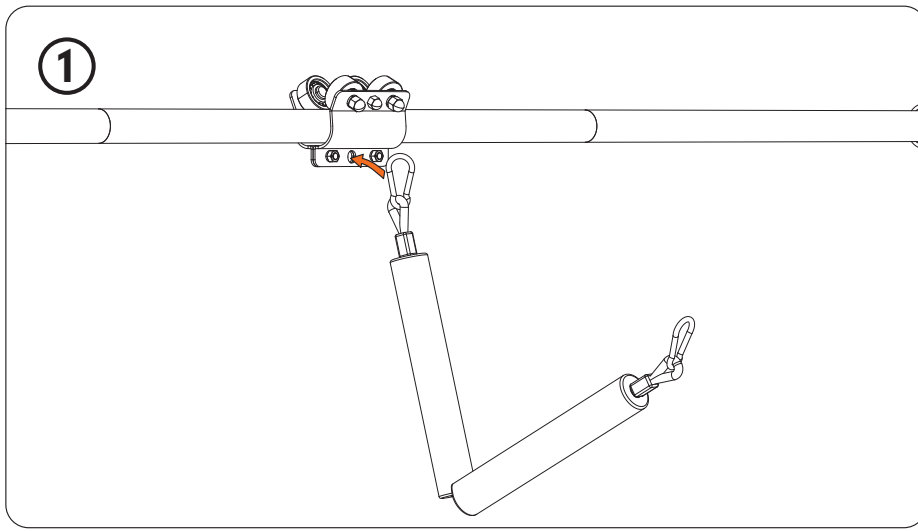

# 56

## SHADE COVER TUBE



①

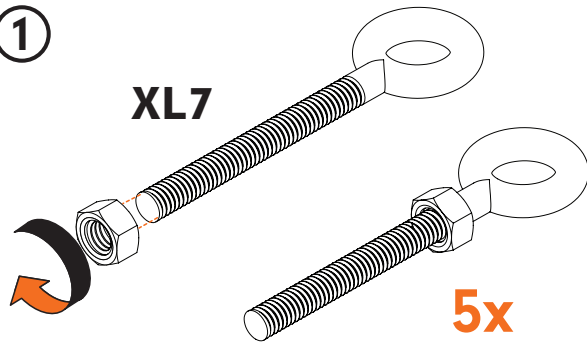

②

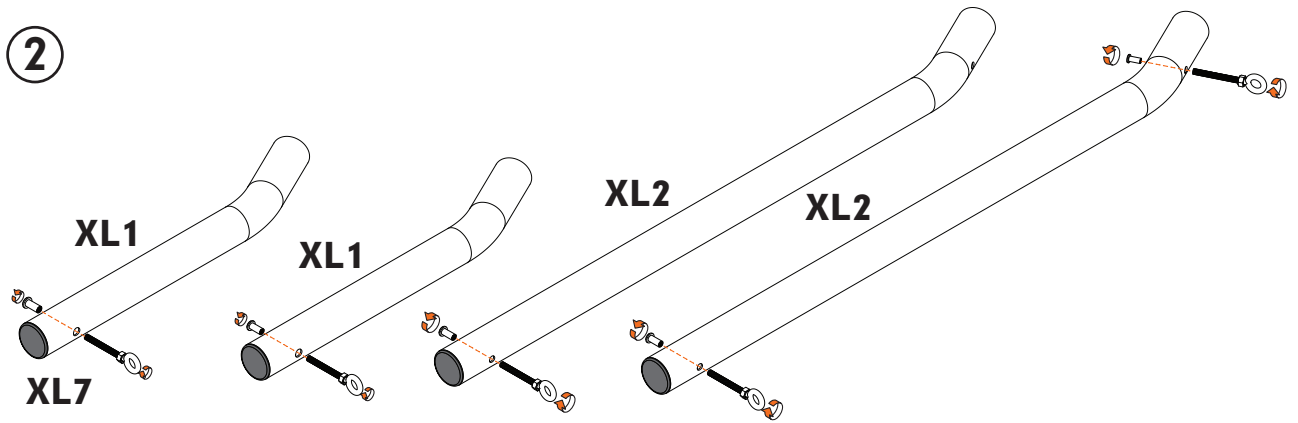

# 57

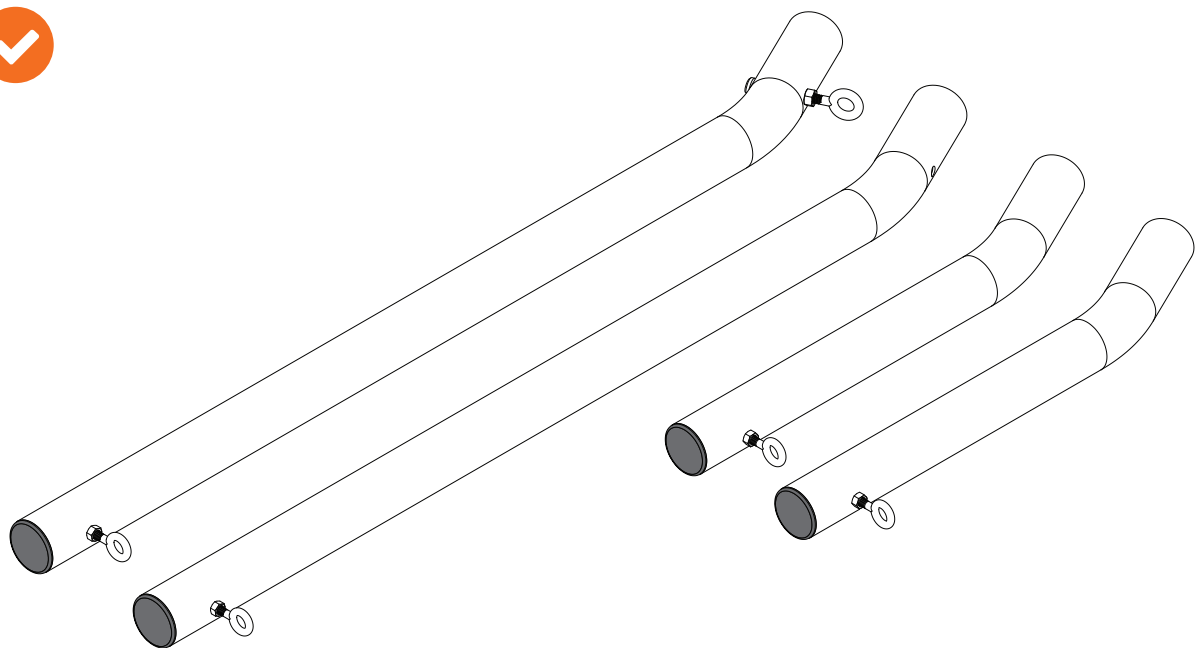

# 58

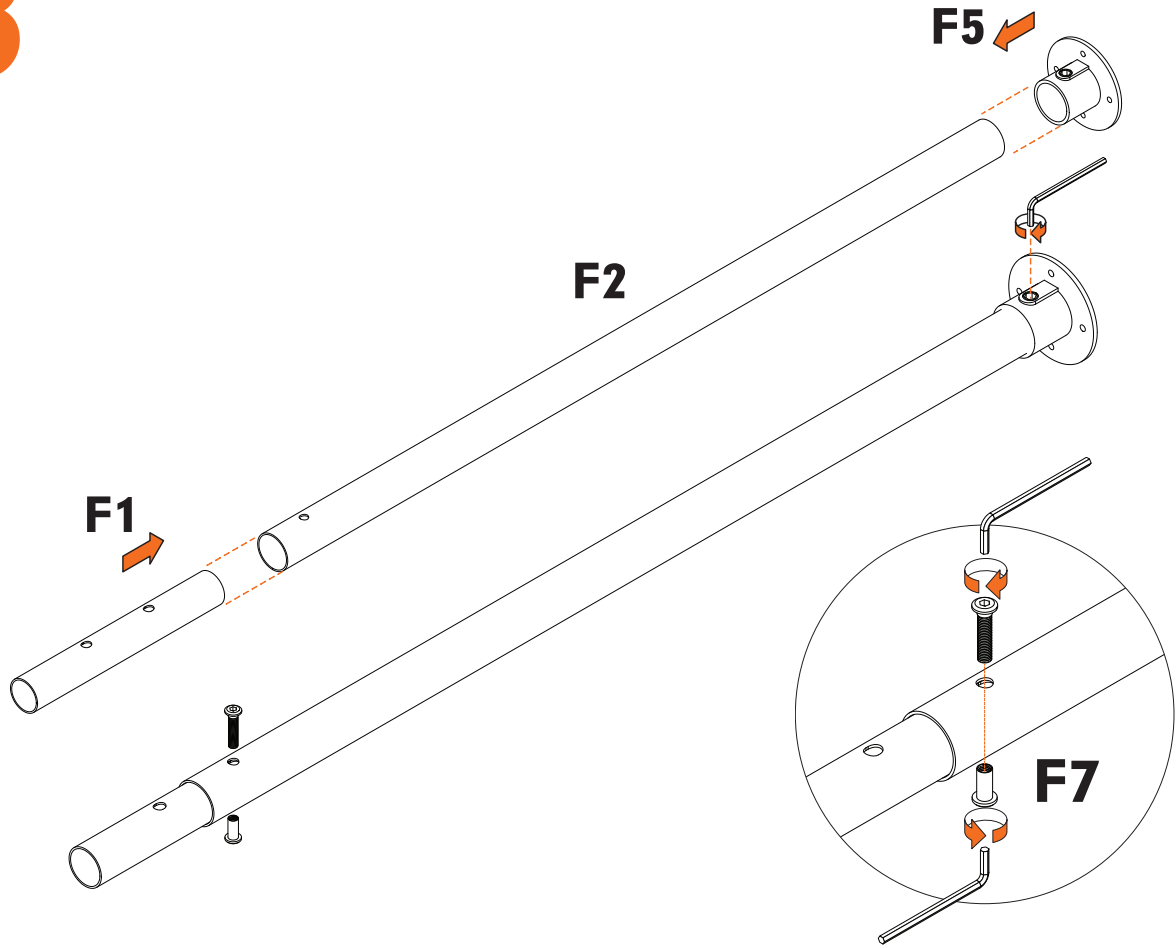

# 59

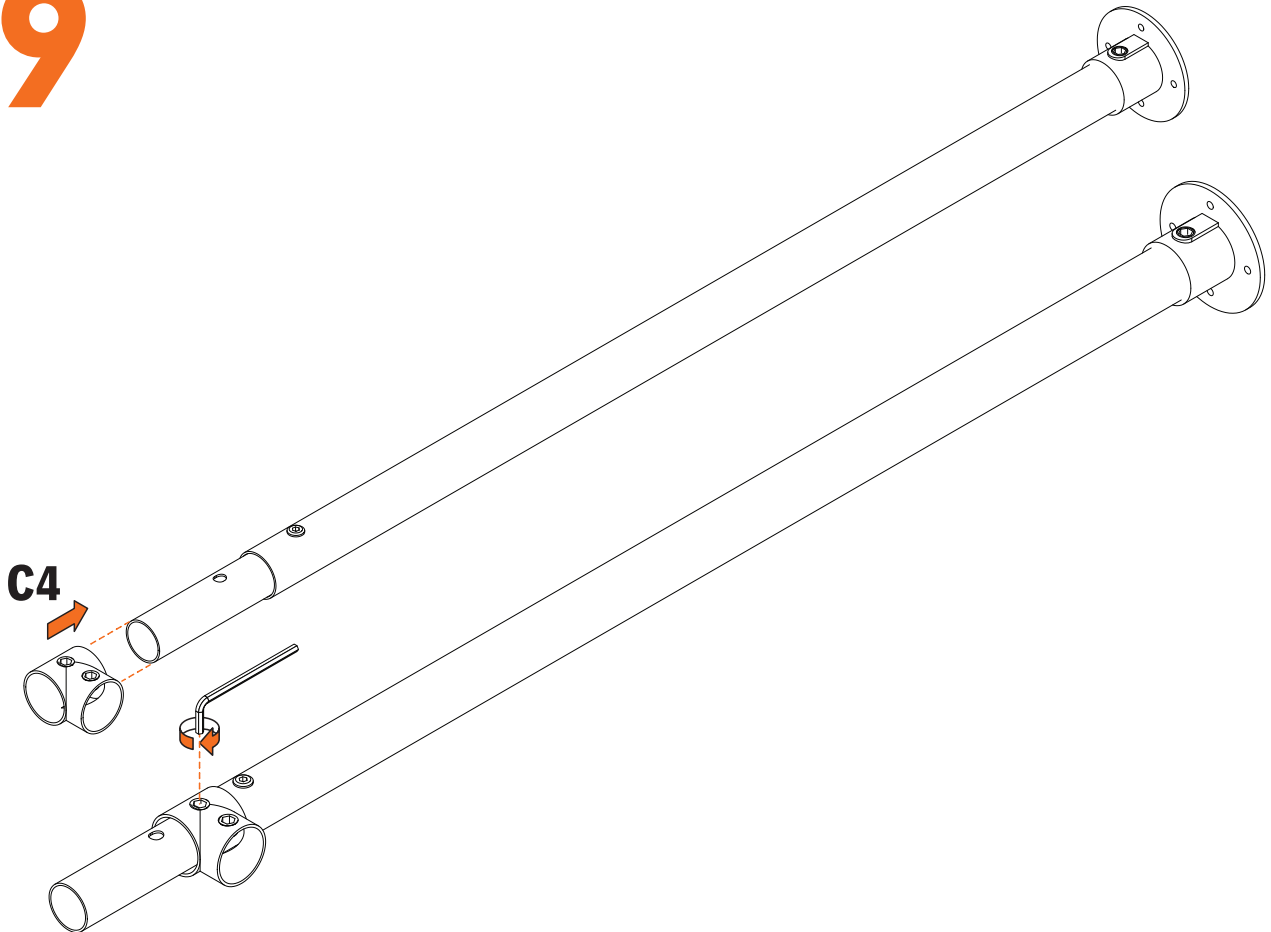

# 60

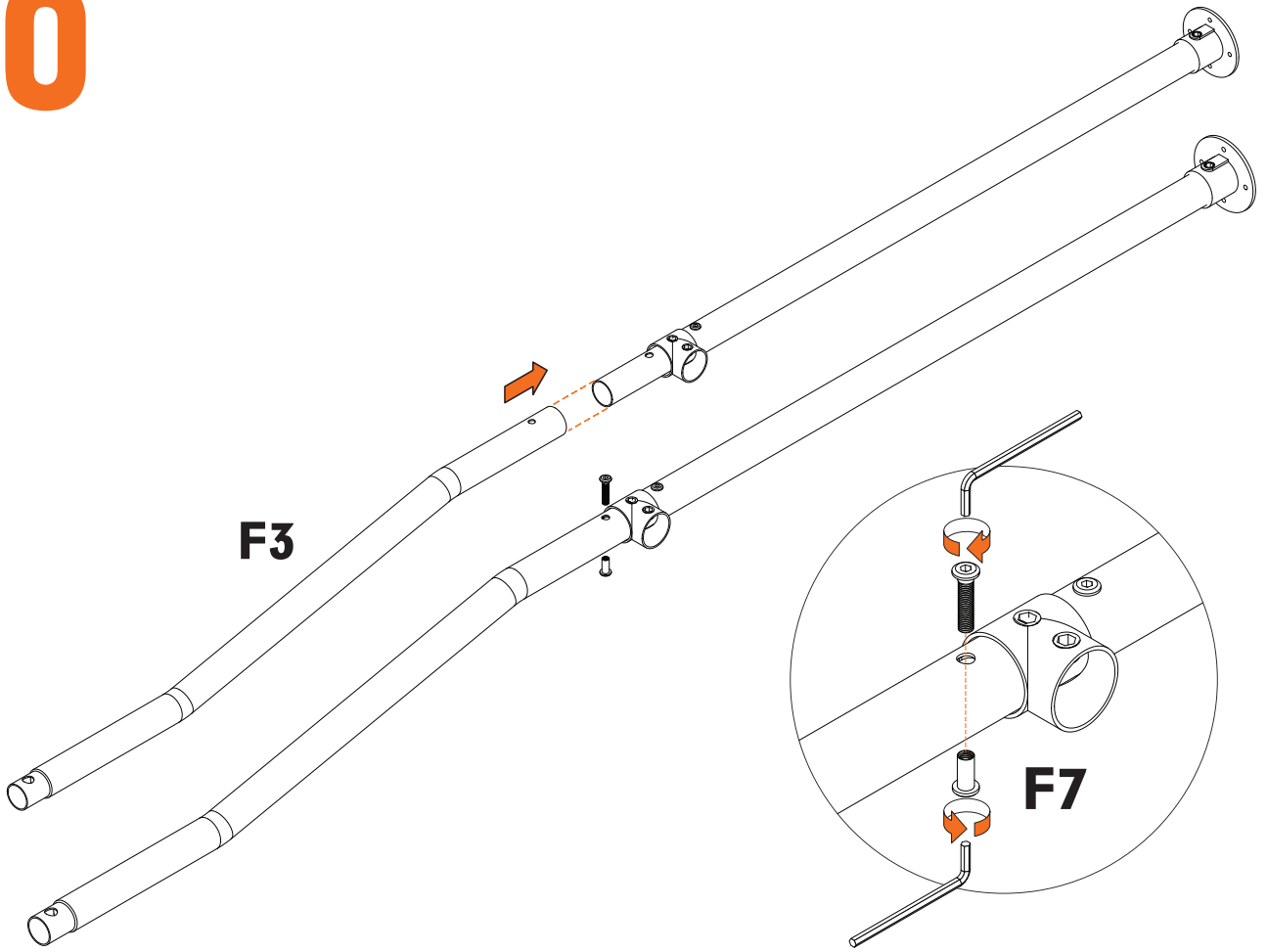

# 61

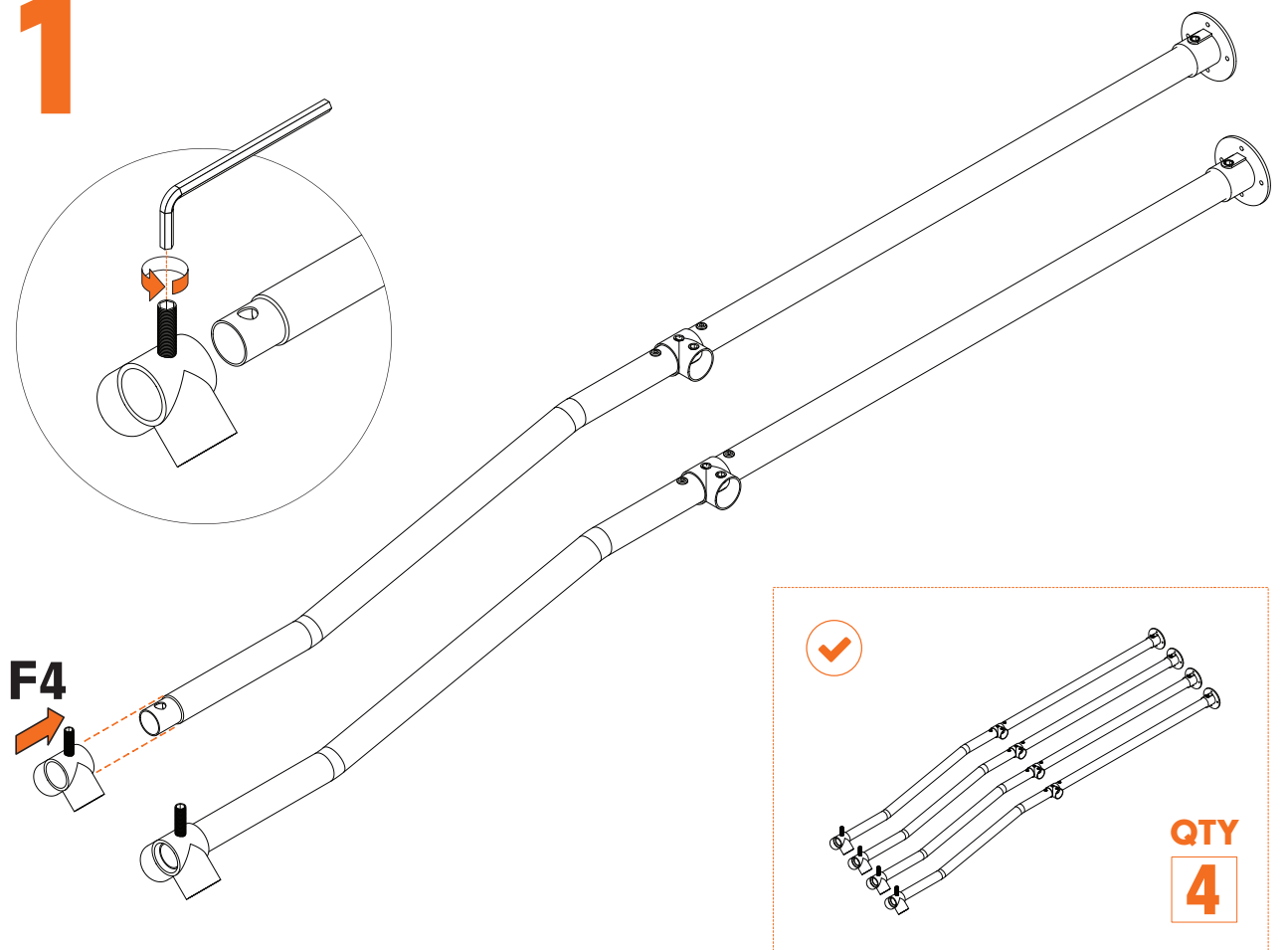

# 62

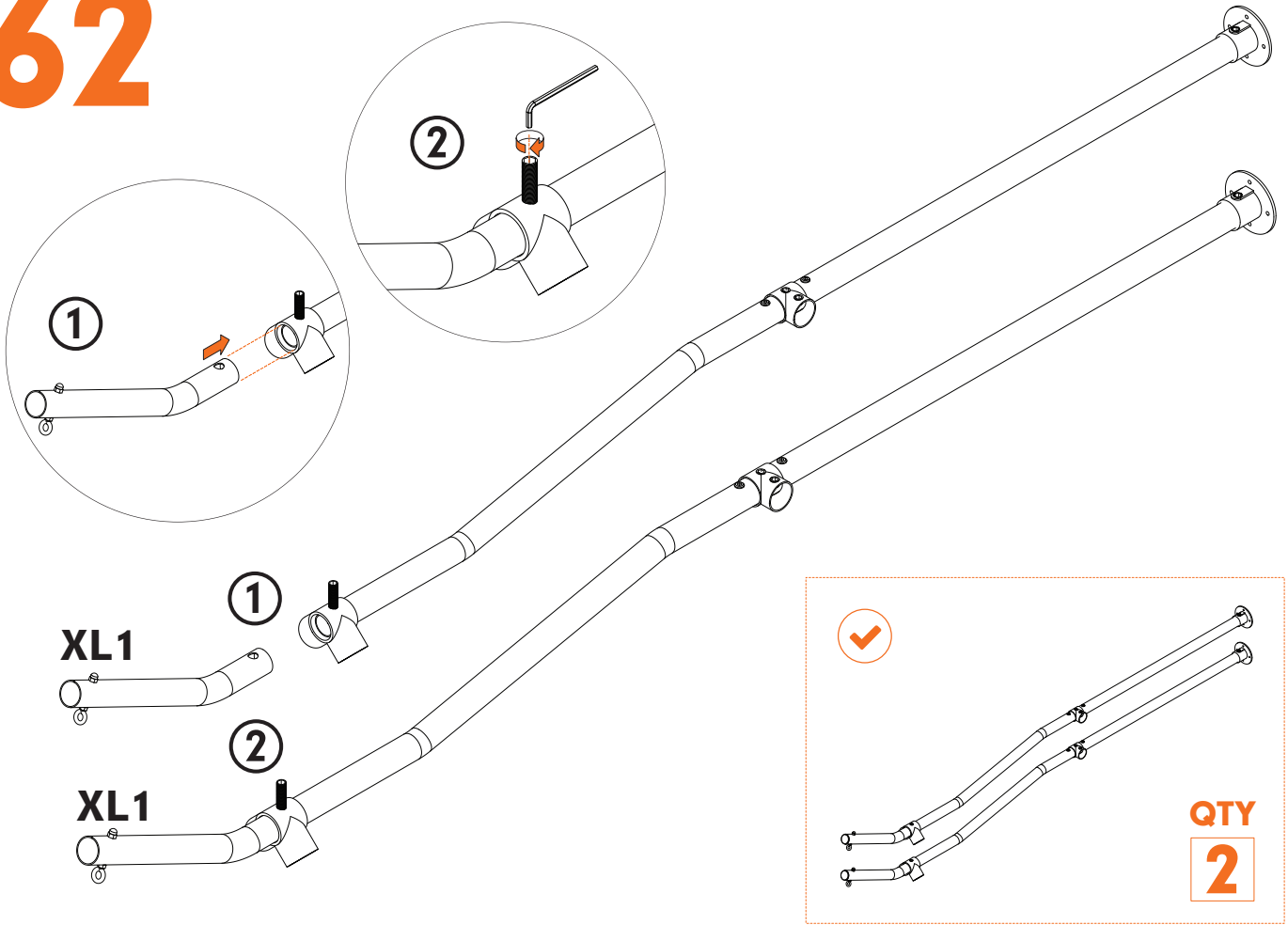

# 63

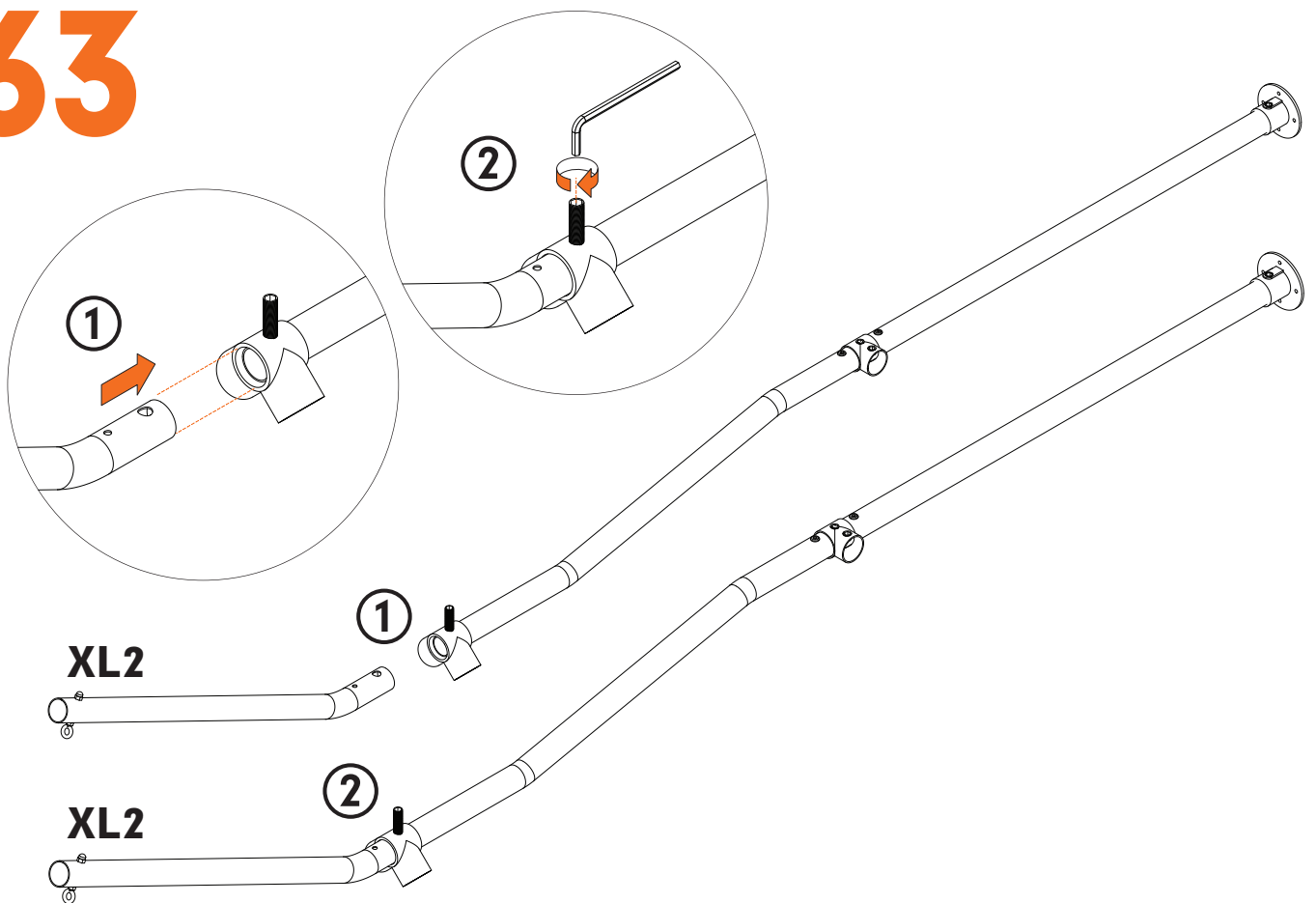

# 64

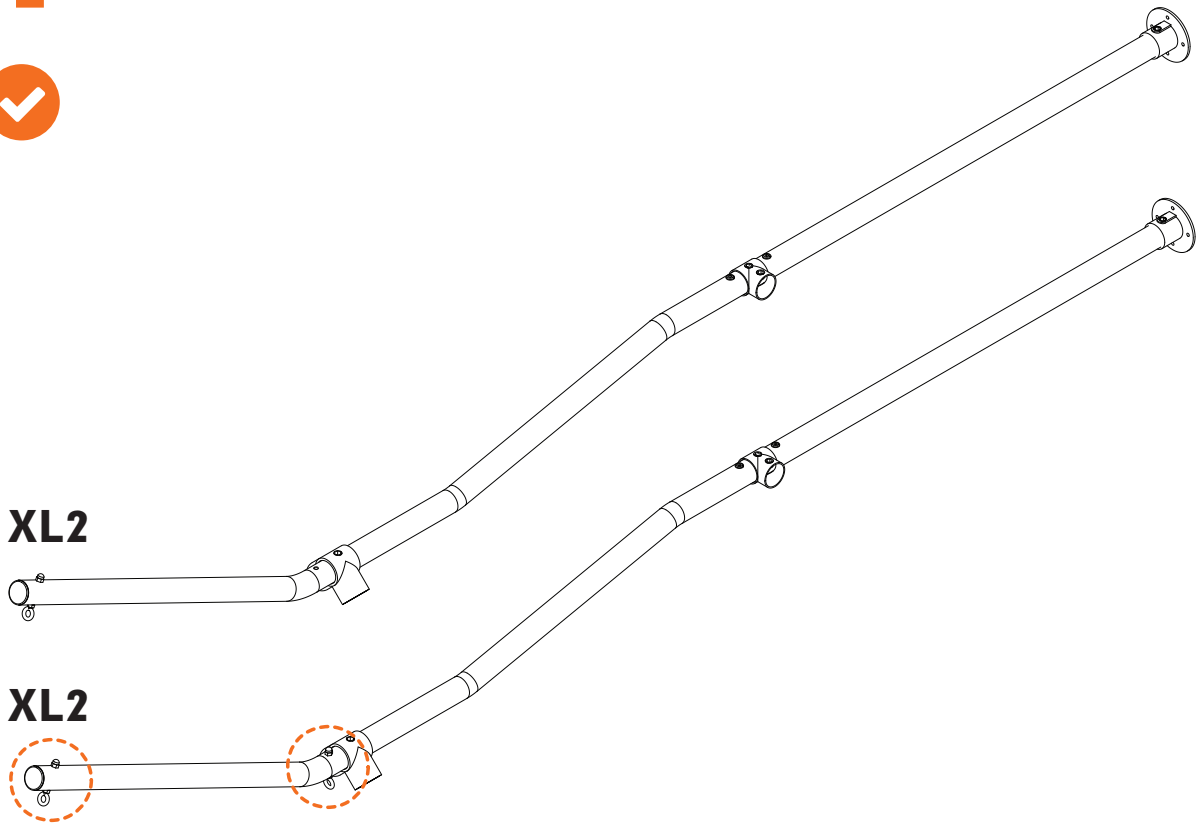

# 65

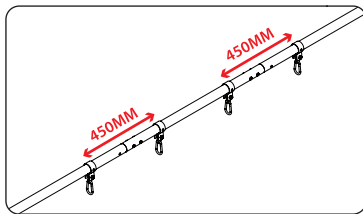

If you will attach **Standard Accessories**: slide on the Accessory Joiners now, where you want to position your accessories. Ensure there is a minimum **450mm** clearance between each swing element.

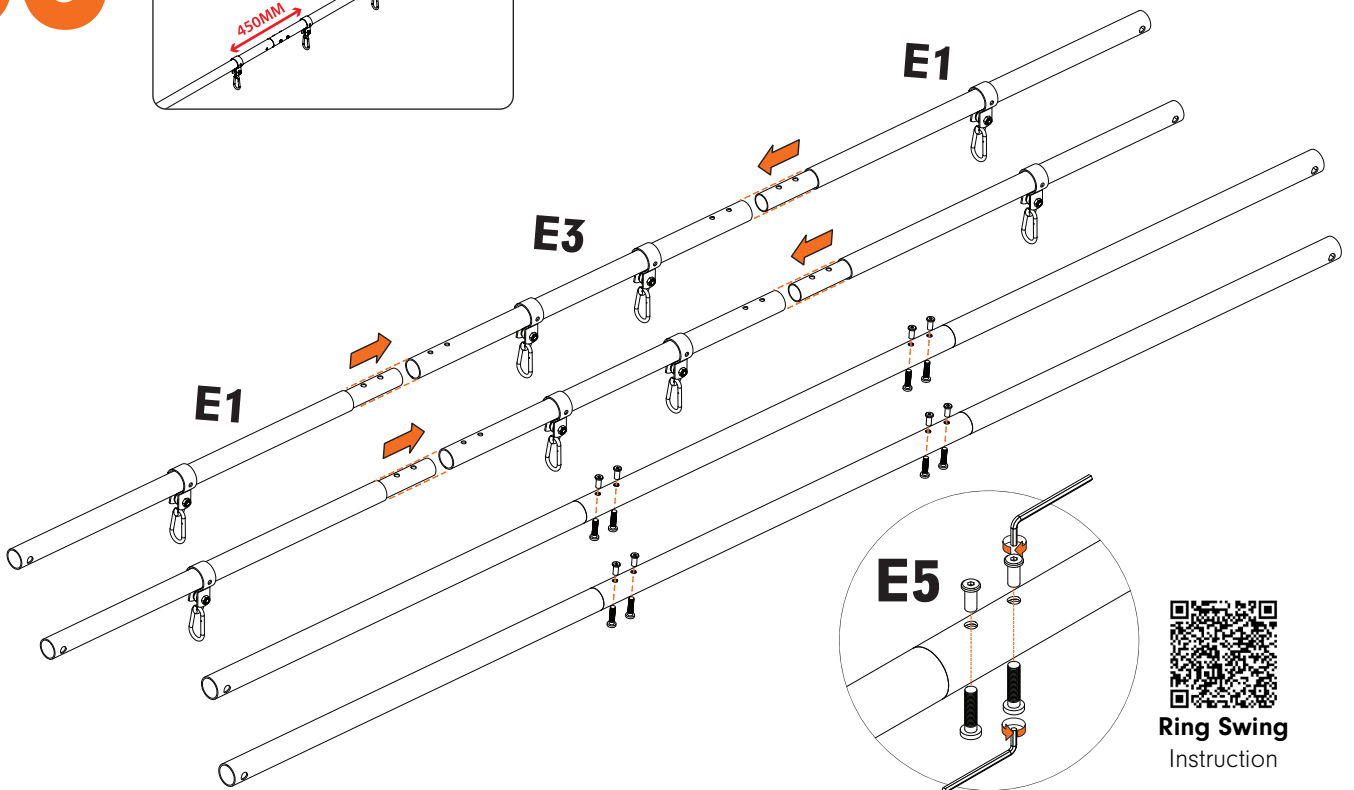

  
**Ring Swing**  
Instruction



**WARNING:** Refer to Ring Swing's manual before continuing with the instructions if you have one.



# 66

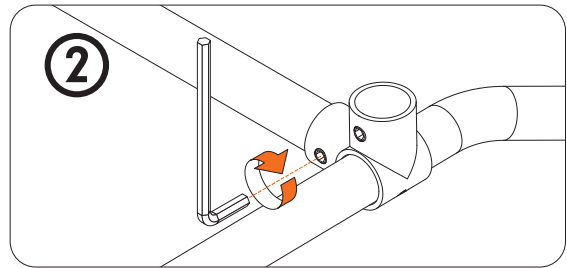
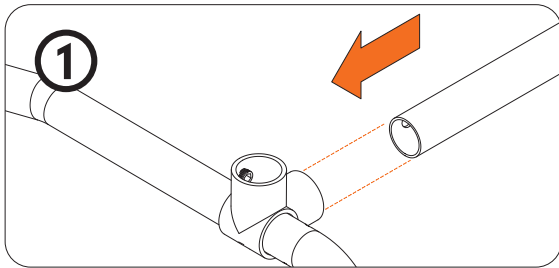
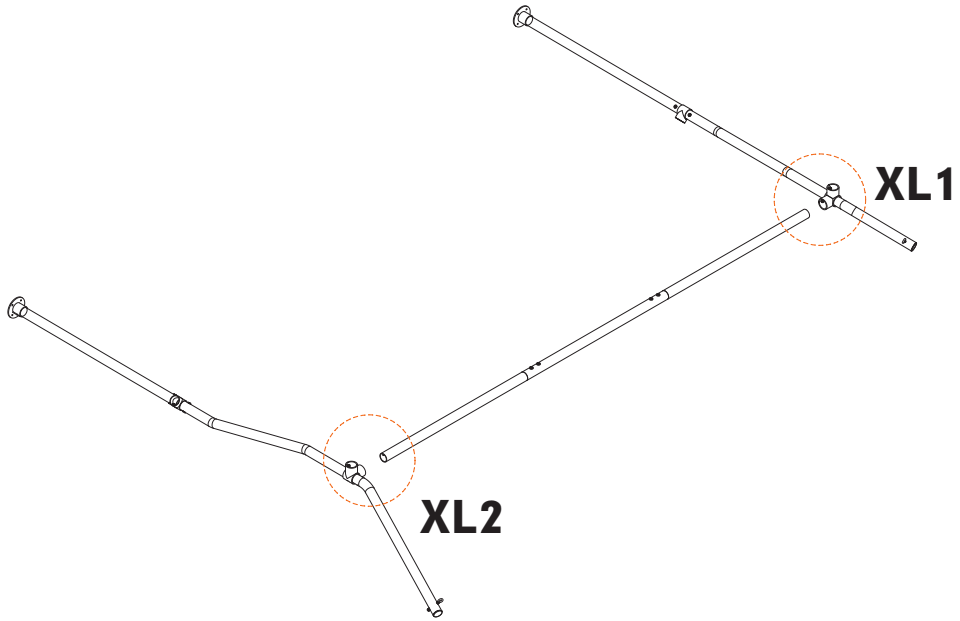

# 67

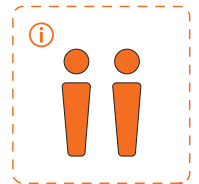
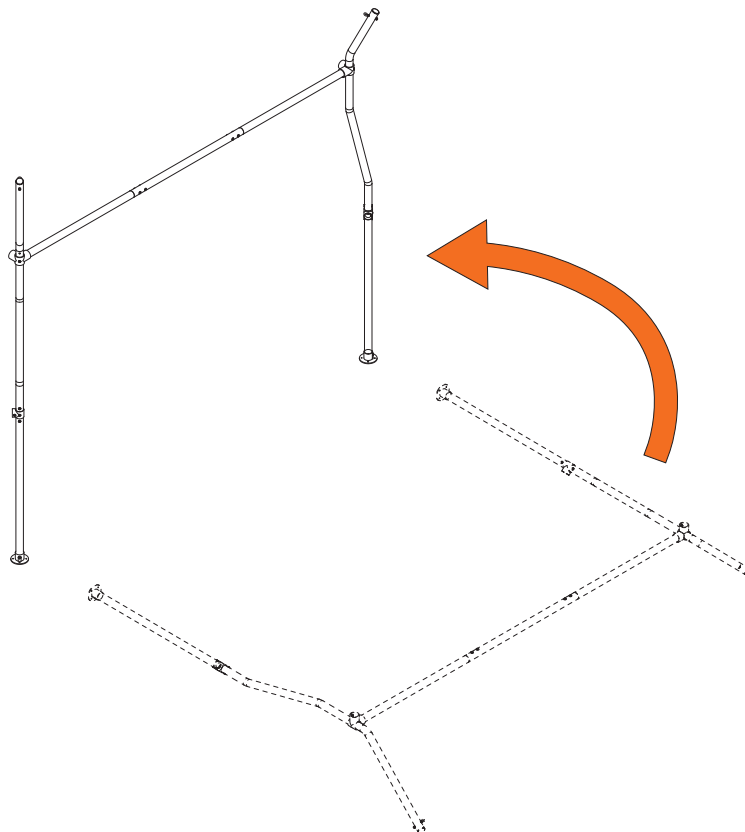

 **WARNING:** Best result with **TWO** people 

# 68

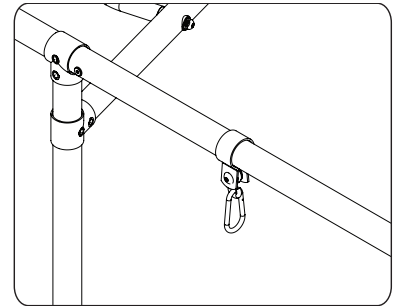
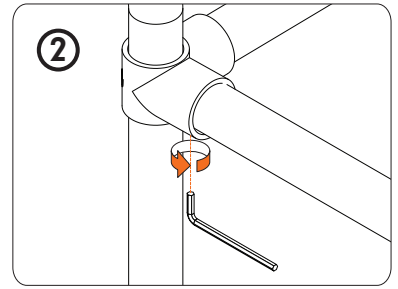
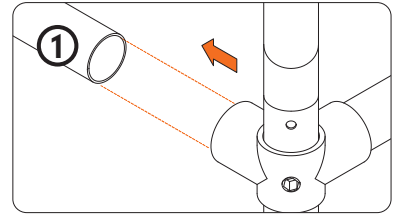
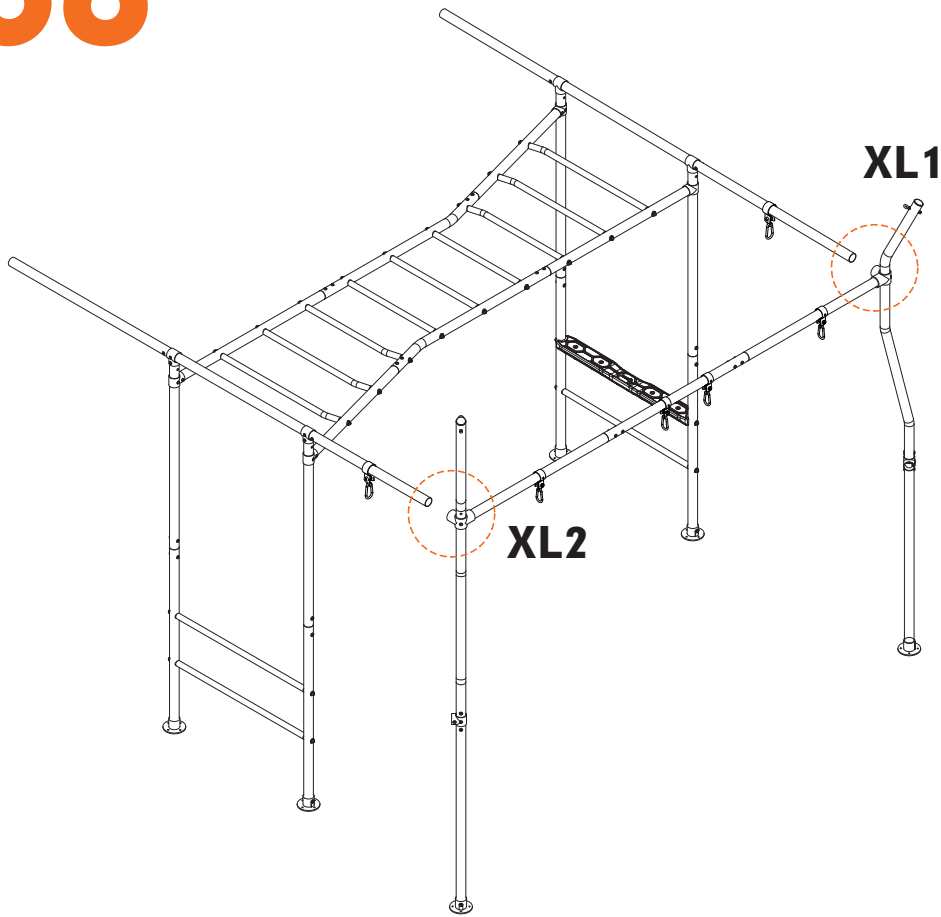

If you will attach **Standard Accessories**: slide on the Accessory Joiners now, where you want to position your accessories.

# 69

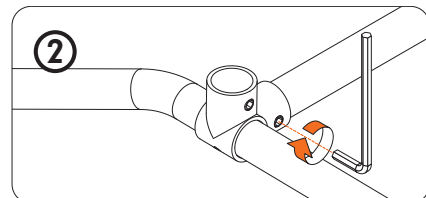
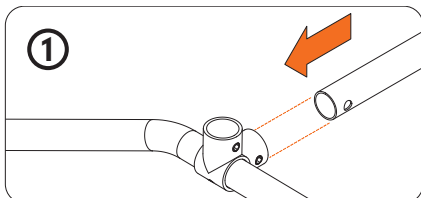
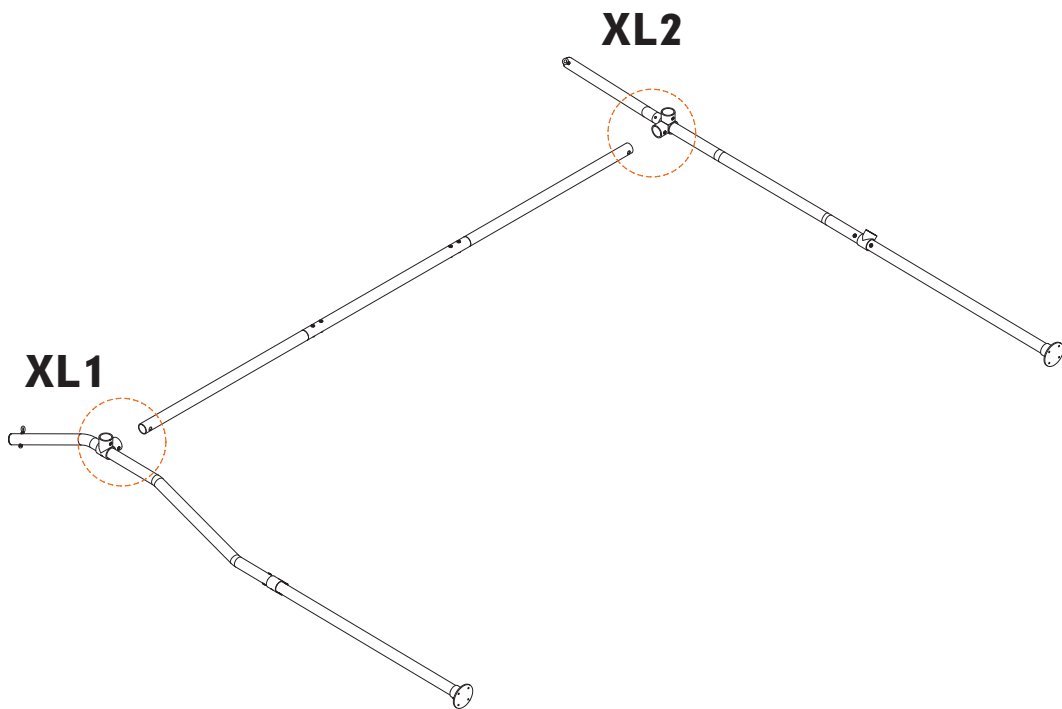

# 70

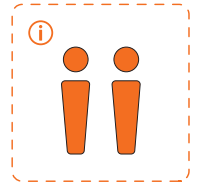
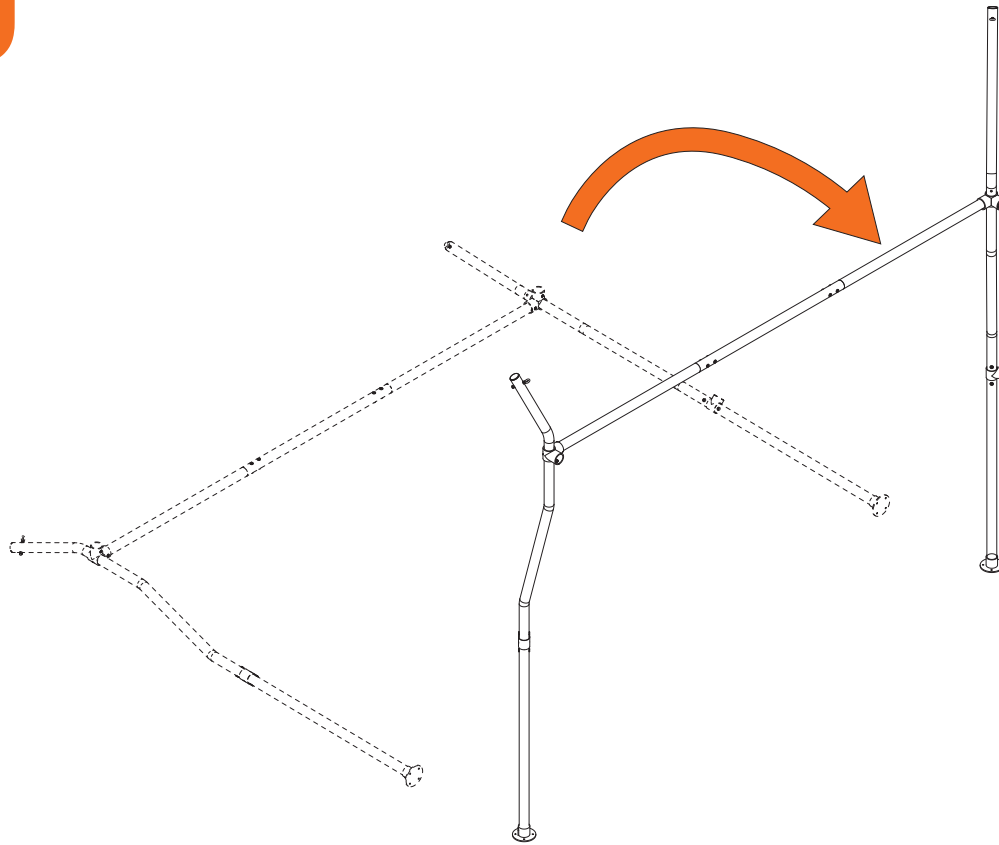

**WARNING:** Best result with **TWO** people



# 71

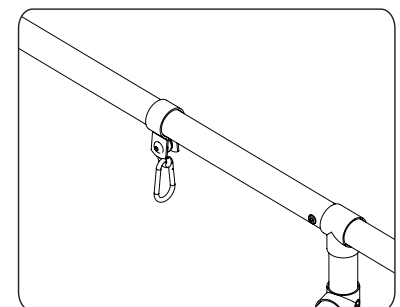
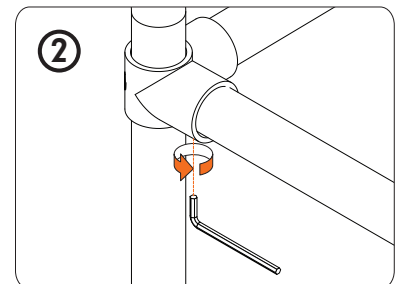
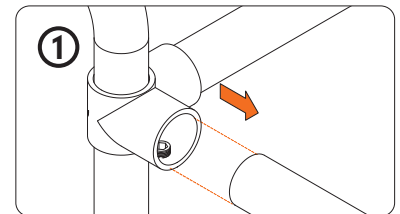
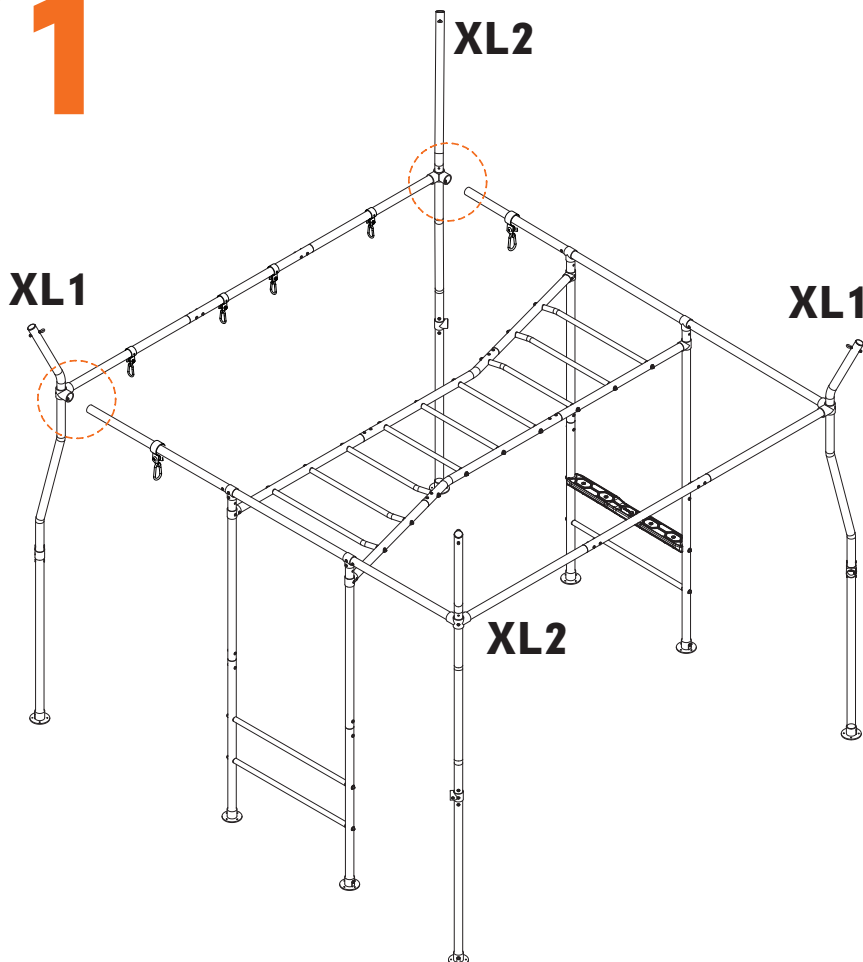

If you will attach **Standard Accessories**: slide on the Accessory Joiners now, where you want to position your accessories.

# 72

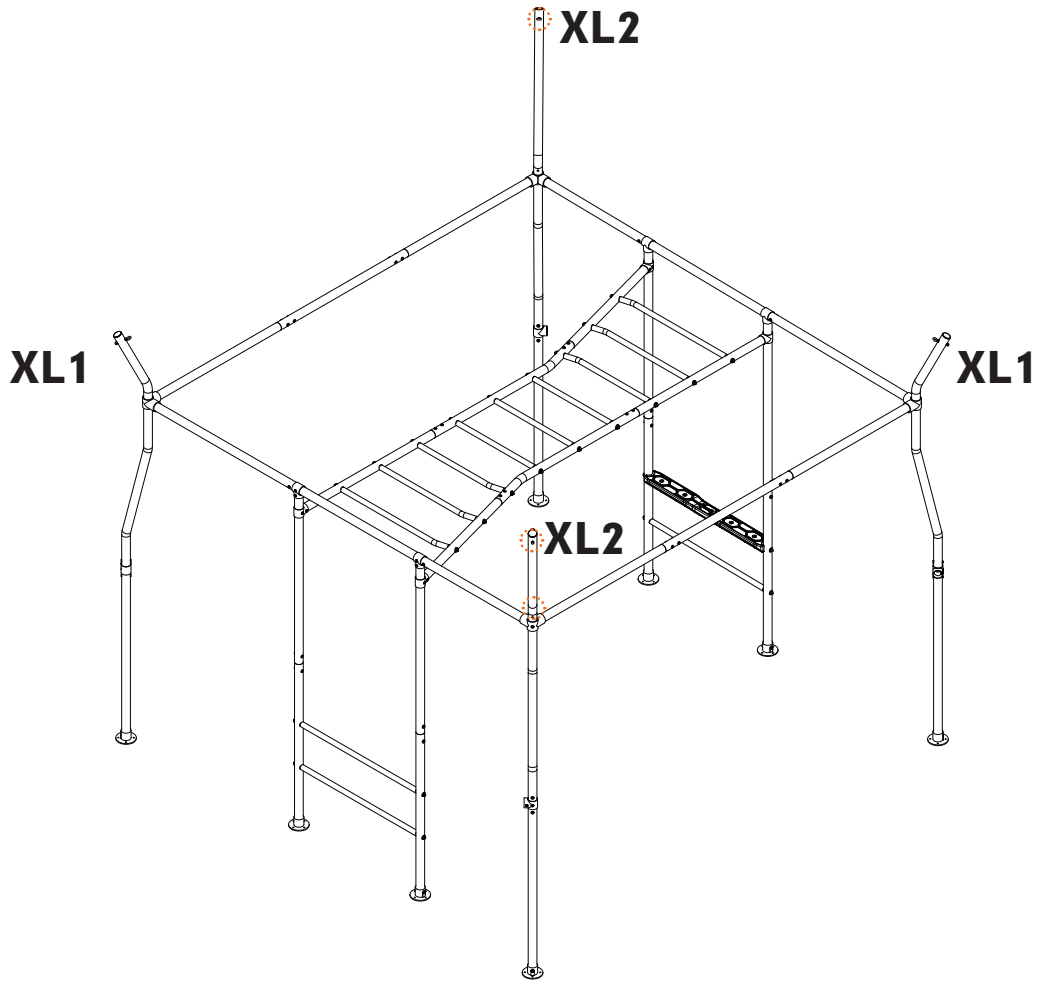

# 73

## SIDE LEGS

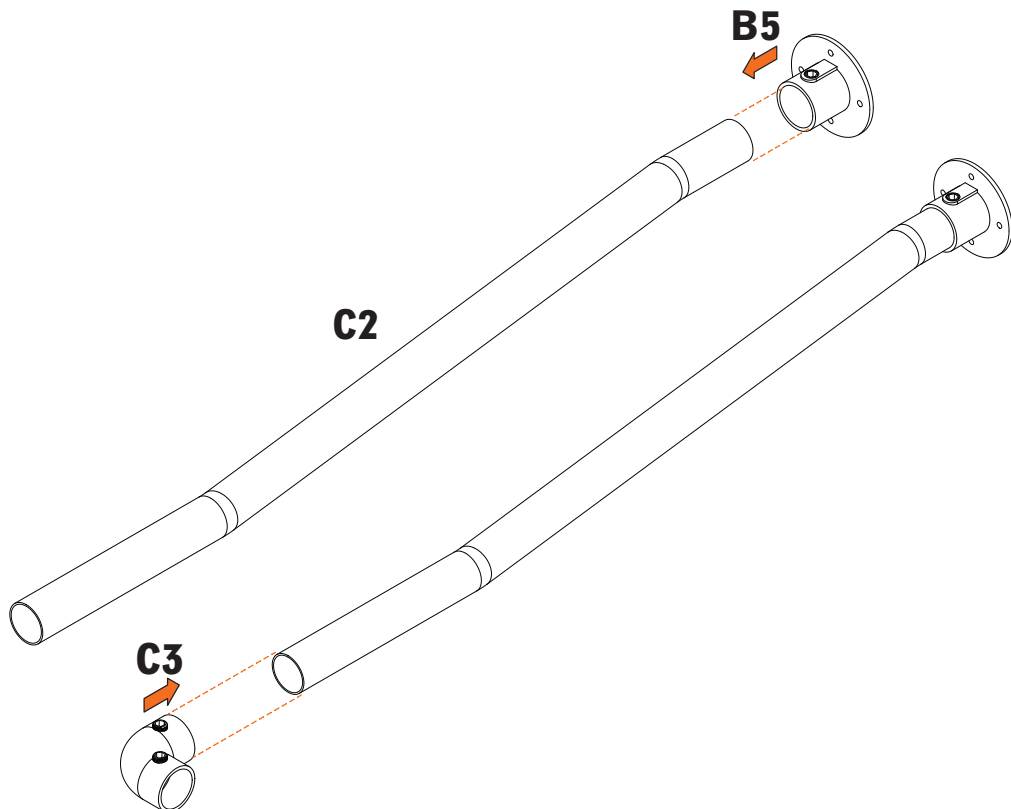

# 74

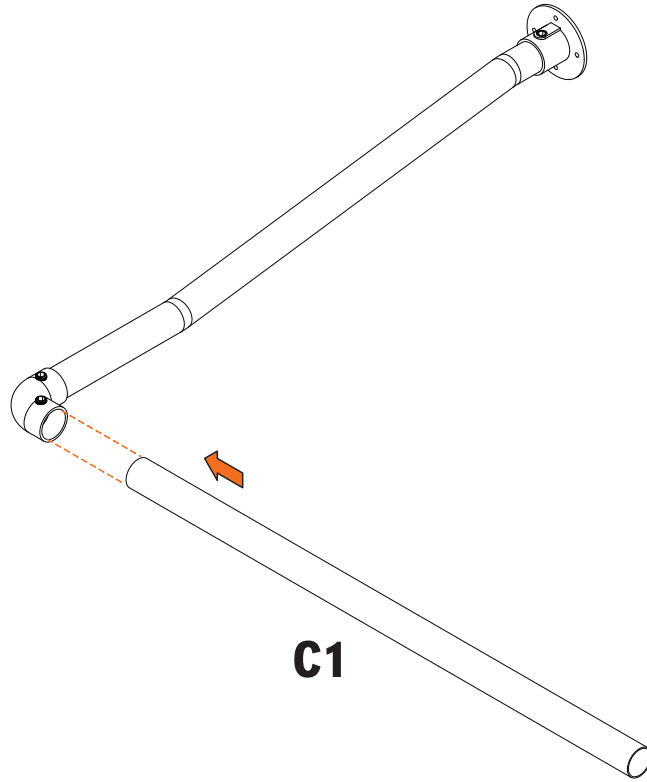

**WARNING:** Do not force any part too far into the Angled Joiner. This will block the part on the other side from connecting completely.

# 75

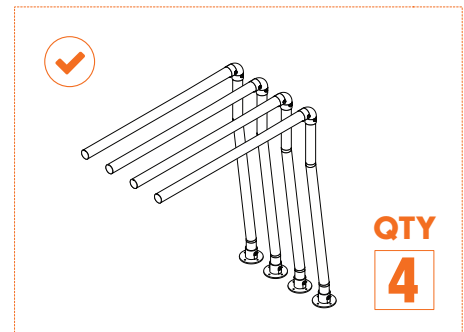
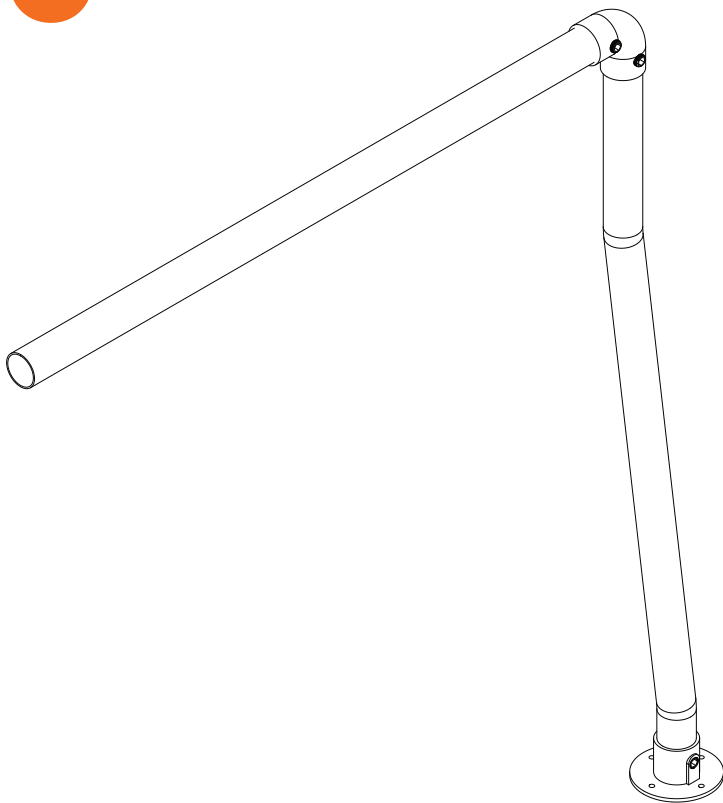

# 76

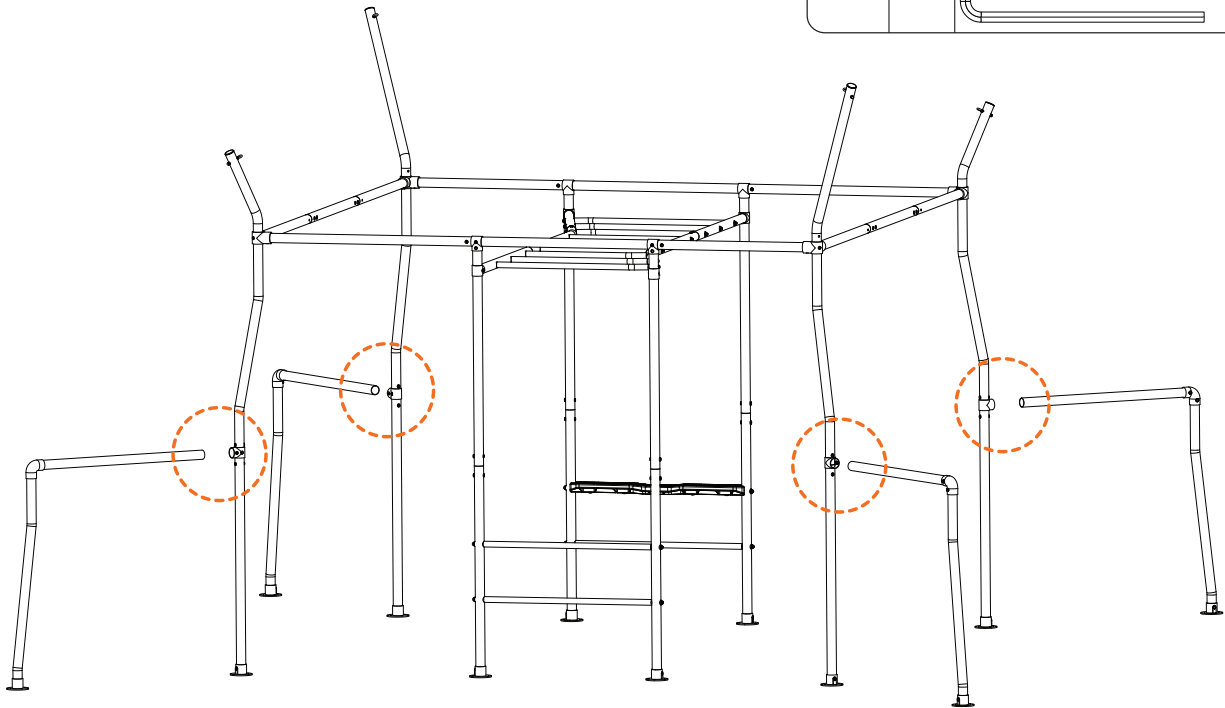
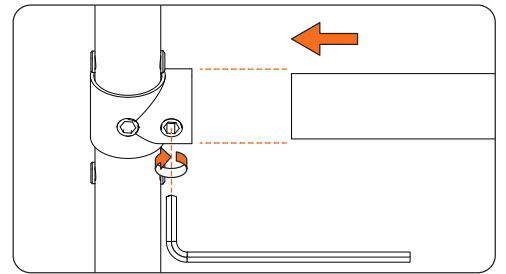

# 77

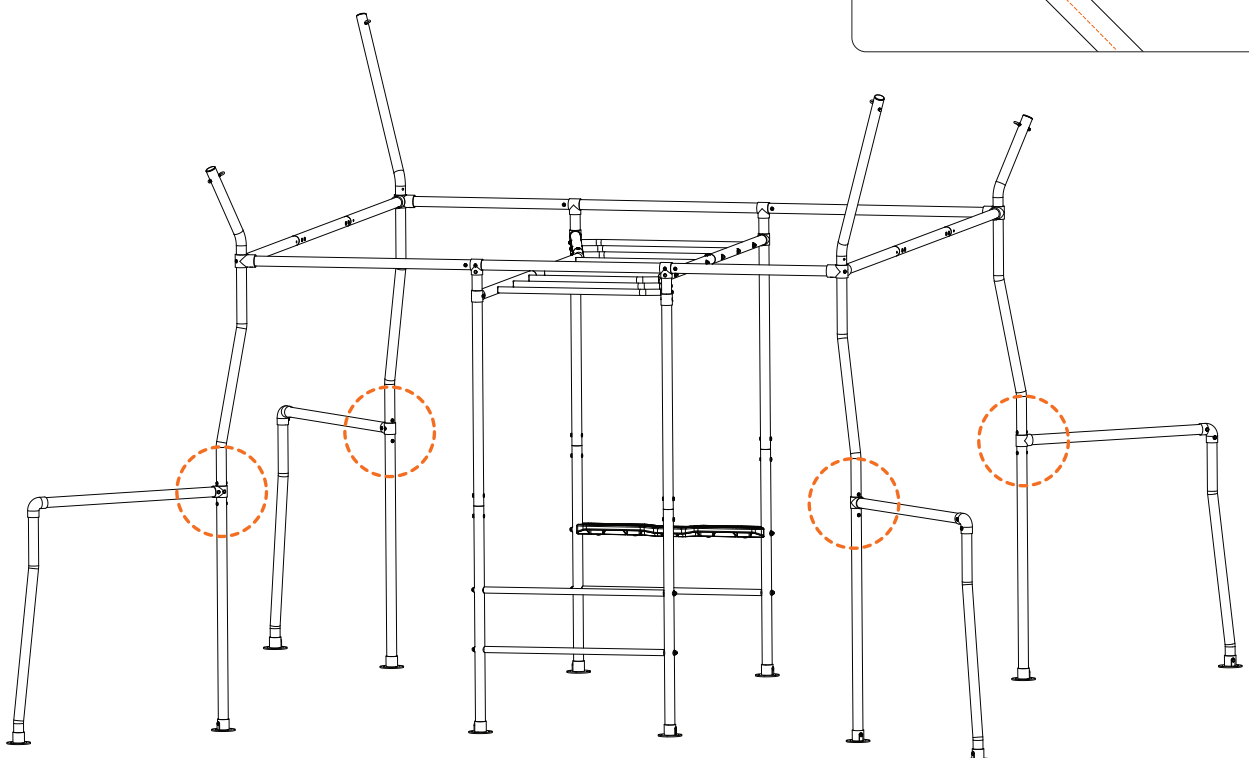
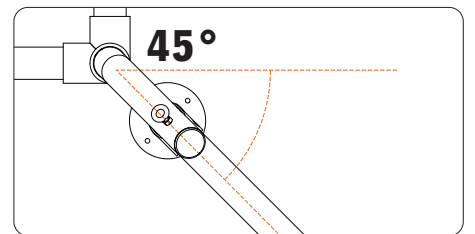



①

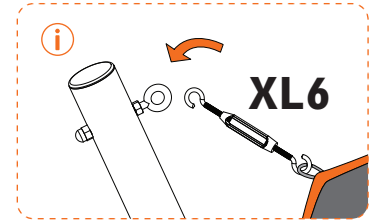
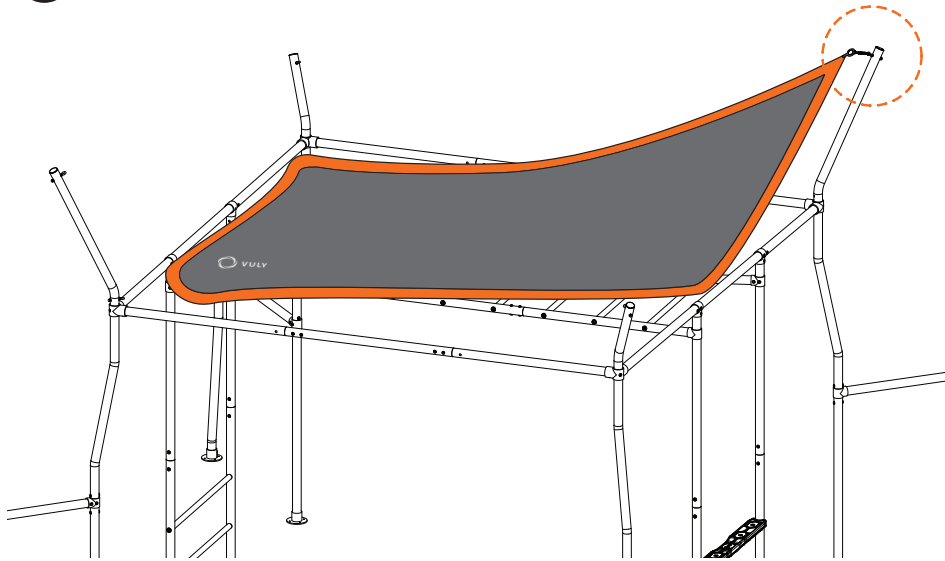

Tips: Loosen tension hook for easier installation

②

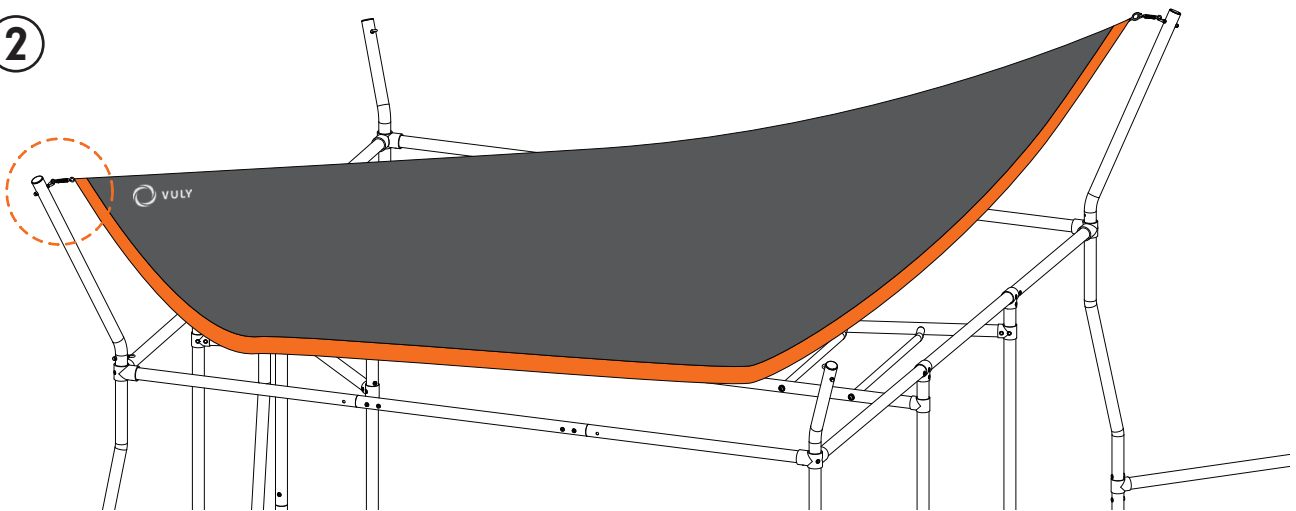

③

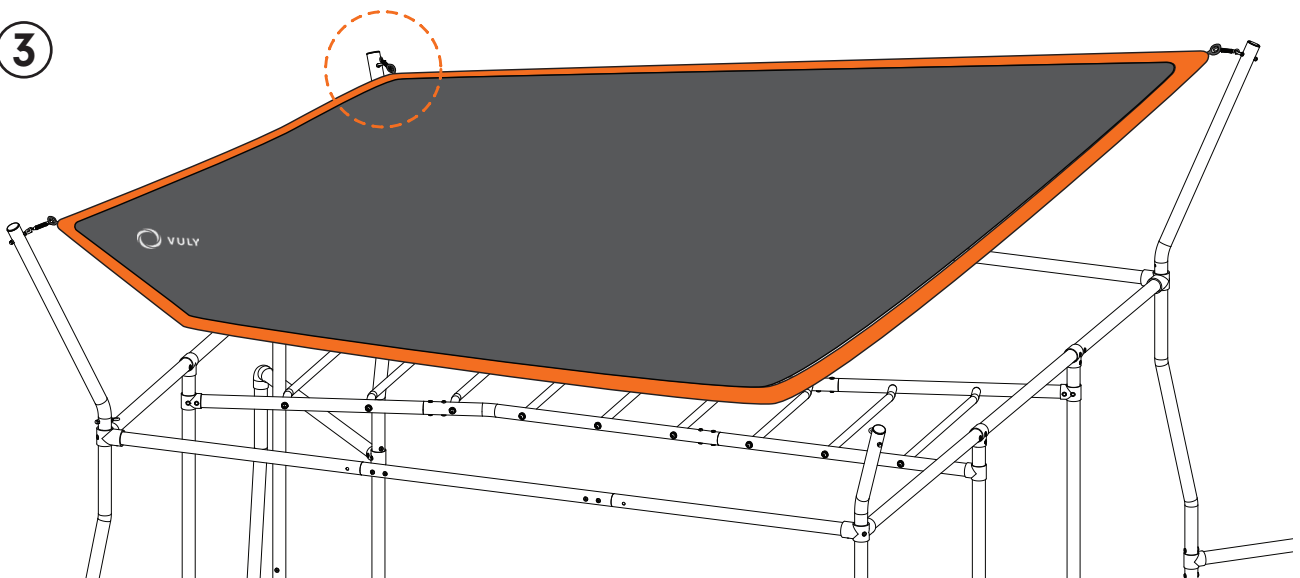

4

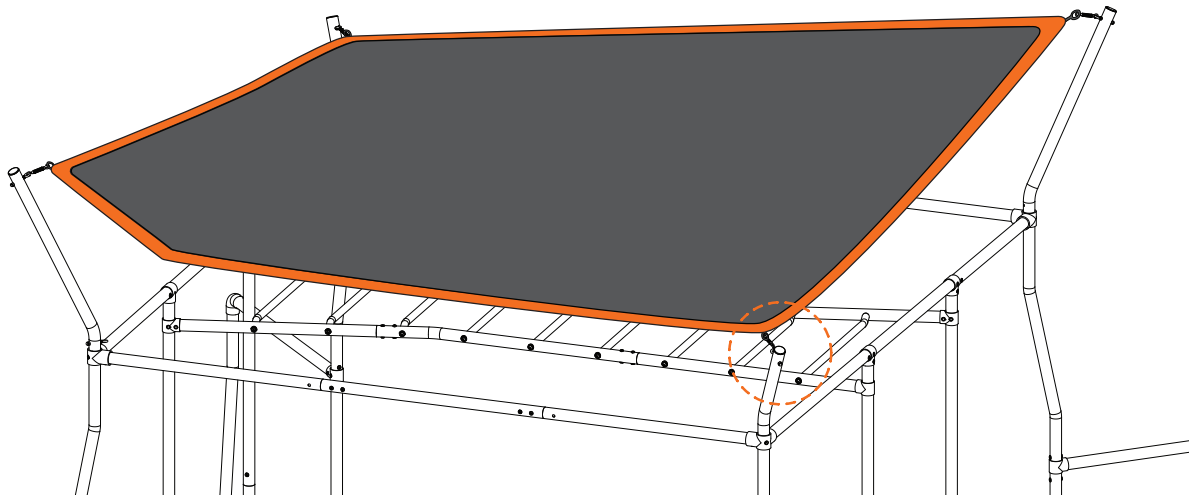

5

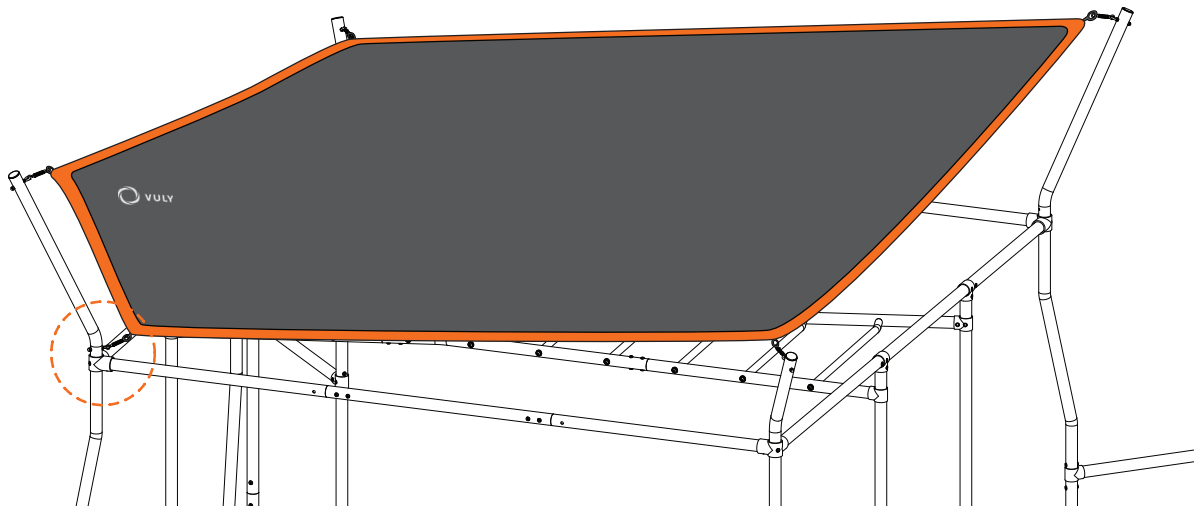

6

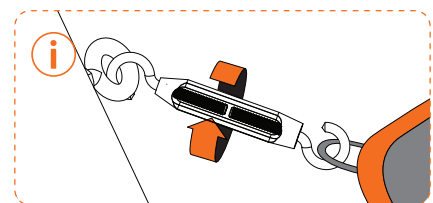
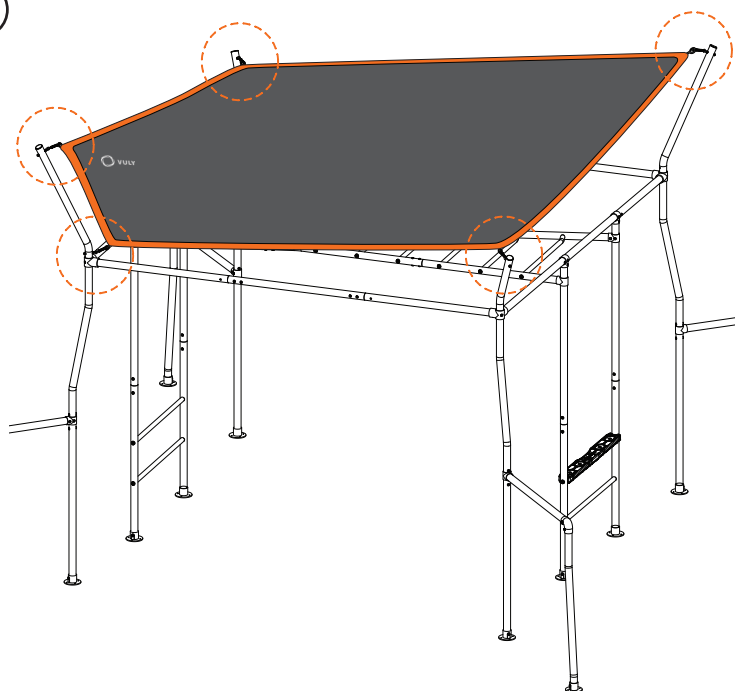

Tighten all tension hooks to secure the shade cover

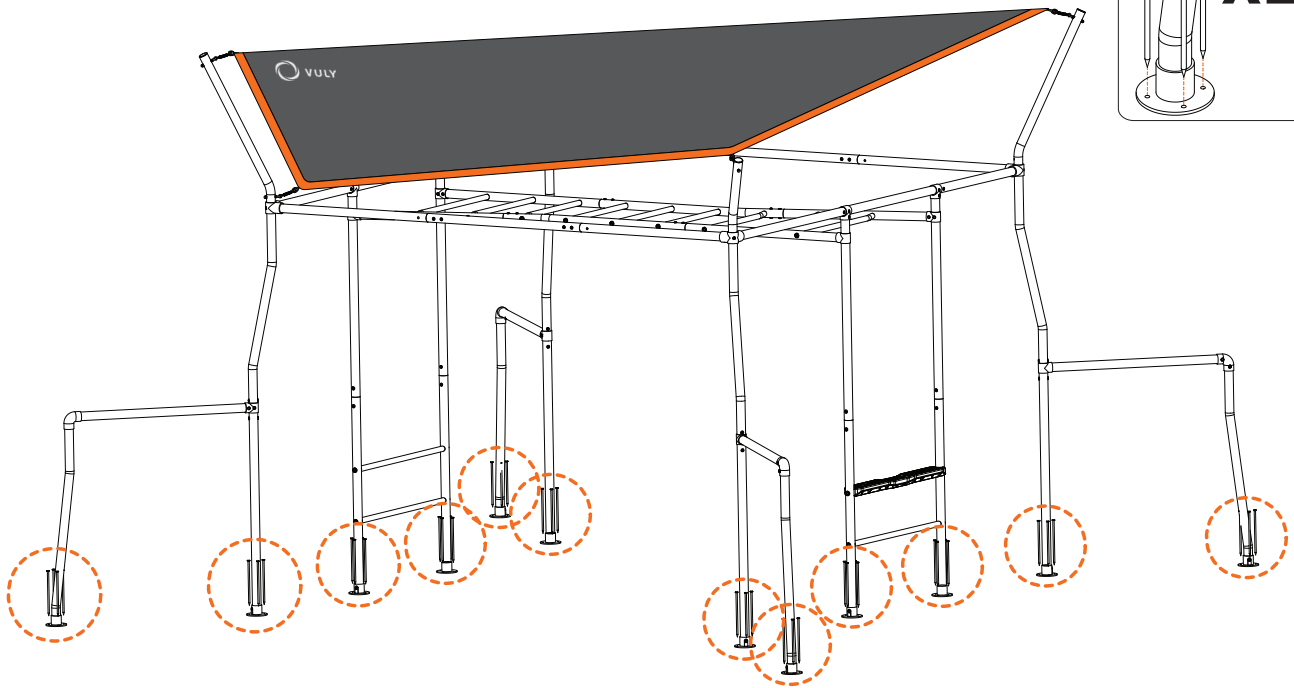
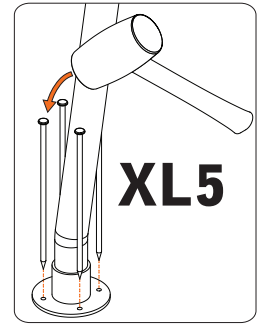

 **TIGHTEN ALL NUTS AND BOLTS AND ENSURE THE PARTS LOCK TOGETHER SECURELY.** 

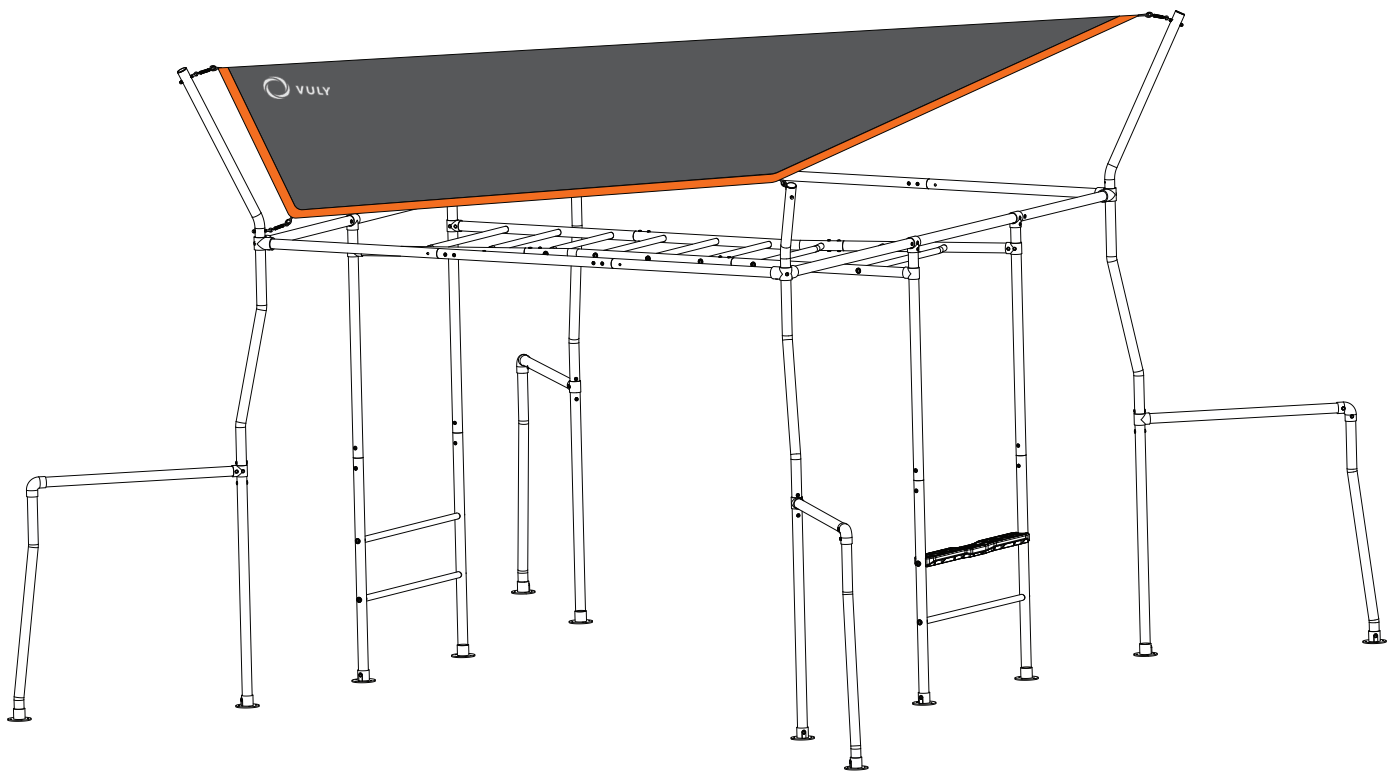

# CONGRATULATIONS!

You have assembled your Quest monkey bar.

## 5.0. Product registration

To access the Half-Price Parts for Life programme or to lodge a Warranty Claim, customers must ensure that their Vuly product is registered with Vuly.

Customers who purchase directly from Vuly (through VulyPlay.com, at the Vuly Showroom or over the phone) automatically have their product registered.

Customers who purchase through an Authorised Reseller must register their product by visiting **VulyPlay.com/Support** and completing the form with a proof of purchase.

## 6.0. Half-price replacement parts

Vuly offers half-price replacement parts to all customers for the lifetime of their purchase through the Half-Price Parts for Life programme.

This programme is subject to change at any time, and it is only available to customers who have purchased either through an Authorised Reseller or directly through Vuly.

Half-Price Parts for Life is only available to customers who wish to replace parts that are core components of their system.

For the monkey bars, these parts include the following elements of the frame:

- Tubes
- Joiners
- Rails
- Bars

The programme does not extend to individual Ropes, Rings, Swings, Shade Covers or accessories.

## 7.0. Warranty

All Vuly products are sold with a manufacturing warranty, which assures that the item is free of defects in workmanship and materials ("warranty").

### 7.1. Warranty periods

Warranty periods do not reset for any reason, unless the customer purchases a new product. In this case, that particular item will be covered by its own warranty period. It does not affect – nor will it increase – warranty periods for other purchased items.

Warranty periods always commence from the date of item delivery.

**This warranty is for use under normal conditions, and it applies for:**

#### **MONKEY BARS**

84 months [7 years] to the frame components.

#### **Accessories**

24 months [2 years] to the Shade Cover.

12 months [1 year] to purchased accessories or attachments not received during a promotional period.

The customer may extend the standard 12-month [1 year] warranty to 36 months [3 years], if they purchase an extended warranty within 7 days of their delivery date.

#### 7.1.1. Second-hand purchases

Vuly warranties apply only for the original purchaser, to a product purchased from Vuly Play or an Authorised Reseller. On-selling a Vuly product voids and all warranties.

#### 7.2. Inclusions

This warranty covers **manufacturing faults** and **defects only**.

If a product is damaged or rendered unsafe as a result of a departure from its design specifications during production, this constitutes a manufacturing fault or defect.

This may occur if – for example – improper welding produces an unstable Frame.

#### 7.3. Exclusions

##### 7.3.1. Damage through wear and tear

This warranty does not extend to normal wear and tear of the product. This may include, but is not limited to:

- Rusting or scratching of steel 1 - 58 components,
- UV deterioration of textile components.

As outdoor products that are actively used, monkey bars and their accessories will experience wear and tear over time.

##### 7.3.2. Damage through weather conditions

Damage to the product that results from weather events – such as rain or wind – are not covered under the warranty. Vuly suggests that you contact your home and contents insurer if your product is damaged by such events.

##### 7.3.3. Damage through improper installation

This warranty does not extend to any failure of the product caused by installation not in accordance with the Vuly Manual. Customers must assemble their Vuly product by following carefully the Installation section of their Vuly Manual.

Furthermore, the warranty does not cover installation provided by a third-party assembly service. It is the customer's responsibility to check all boxes and confirm that all components are included in the correct condition before installing.

##### 7.3.4. Damage through insufficient care or maintenance

This warranty does not extend to accelerated decay of the product caused by poor care or maintenance. It is essential that customers regularly check, and follow the advice of, the Care and Maintenance section of their Vuly Manual to ensure that their product lasts as long as possible.

### 7.3.5. Damage through inappropriate use

This warranty will be void if the product is used for any other activity besides those for which it was intended, or used in any way that is unadvised in this Manual. Vuly products constitute recreational outdoor products and accessories for such products. They are not intended for professional use.

Any evidence that inappropriate actions that have led to product failure will not be covered by the warranty. Similarly, replacement parts or repairs needed to mend such damage will not be covered under the warranty.

### 7.3.6. Damage through salt water proximity

This warranty (on steel components, specifically) will be reduced by 50% where the Vuly product is assembled within 1.6 km of a salt water environment or where it is subject to ocean spray.

### 7.3.7. Personal Injury

The warranty does not cover personal injury or losses due to any of the above: wear and tear, weather conditions, inappropriate installation, insufficient care or maintenance or inappropriate use, nor does it cover damage due to negligence or accidents.

### 7.3.8. Installation

This warranty does not cover any installation service. If a customer pays for installation of their Vuly product at the time of purchase, this is a one-time service only. The customer may not claim installation costs for any replacement parts.

## 7.4. Warranty Claims

If a customer believes that a Vuly product is faulty or defective, they must discontinue use and submit a Warranty Claim.

A customer must not attempt to use a product if any part is faulty or defective, as it may be dangerous. Any damage that the user causes as a result of using faulty or defective products will lead to voiding of the warranty.

### 7.4.1. Making a Warranty Claim

To fulfill a warranty claim, a customer must submit an online Warranty Claim at [VulyPlay.com/Support](http://VulyPlay.com/Support).

Submitting the online Warranty Claim form requires the customer to provide:

- Details of their purchase – including date,
- Batch number,
- Clear photographic evidence of the manufacturing fault or defect.

If the customer does not provide all details that the form requires, their Warranty Claim will not be assessed.

Vuly may take up to 7 days to process Warranty Claims upon a completed submission. It may take a further 7 days for replacement parts to reach the customer.

### 7.4.2. Successful Warranty Claims

If Vuly accepts a customer's Warranty Claim, Vuly will replace the faulty or defective parts, not offer refunds.

*Successful Warranty Claims lodged within 60 days of the delivery date:*

Vuly will replace the damaged parts free of charge. Vuly will also cover any costs associated with shipping the replacement part.

*Successful Warranty Claims lodged after 60 days of the delivery date:*

Vuly will replace the damaged parts free of charge. The customer must cover any costs associated with shipping the replacement part.

### 7.4.3. Walk-in Warranty Claims

If a customer wishes to make a Warranty Claim while on the Vuly premises, they must first submit an online Warranty Claim at [VulyPlay.com/Support](http://VulyPlay.com/Support) – providing all required details.

### 7.4.4. Refunds

In all instances of successful warranty claims, Vuly offers replacements parts only. Vuly provides refunds only at their discretion. Any refunds granted to the customer exclude third-party fees, such as assembly services and credit card surcharges.

### 7.4.5 Claiming on non-Vuly products

Products sold alongside Vuly that are not Vuly-branded are subject to the warranties provided by the companies that supply them. The customer must contact these external companies to make a warranty claim; Vuly itself will not assess claims made against non-Vuly products.

## 7.5. Australian Consumer Law

Our Goods come with guarantees that cannot be excluded under the Australian Consumer Law. You are entitled to a replacement or refund for a major failure and for compensation for any other reasonably foreseeable loss or damage. You are also entitled to have the Goods repaired or replaced if the Goods fail to be of acceptable quality and the failure does not amount to a major failure.

## 8.0. Missing parts

If a customer believes that a Vuly product does not include all necessary parts, they must immediately lodge a Missing Parts Claim at [VulyPlay.com/Support](http://VulyPlay.com/Support).

A customer must not attempt to use a product if any part is incomplete, as it may be dangerous. Any damage that the user causes as a result of using incomplete products will lead to voiding of the warranty.

Vuly products are delivered to Vuly warehouses prepackaged; we are unable to check the boxes prior to delivery to ensure that they contain all the required parts. While the missing part rate during packing is very low, some parts may also fall out in transit due to small, unintentional tears in their boxes.



See [VulyPlay.com/Terms](https://www.vuly.com/terms) for the most recent Vuly warranty policies, terms and conditions.