



Swing Set (frame)



MANUAL

Visit [VulyPlay.com/Installation](https://www.vulyplay.com/Installation)
for video instructions

ATTENTION!

Safety information, installation and use instructions.

Read prior to installing and using the swings.

See **VulyPlay.com/support** for any updates to these instructions.

WARNING!

- Minimum user age - 6 years. Only for domestic and outdoor use.
- Maximum user weight per swing station - 50 kg (110 lb).
- Maximum combined user weight per swing set section - 120 kg (265 lb).
- Adult assembly required. Adult supervision required at all times.
- Ensure that the Swing Set is secured with anchors or bolts before use.

Vuly Play

95 Ingleston Rd, Brisbane QLD 4154

AU: 1300 667 514

US: 1-800-467-1421

www.vulyplay.com

Contents

Read and follow all instructions in this manual before using your product, and do not use any Swings in any way that is not described in this manual.

1.0. Care and Maintenance	4
2.0. Safety Information	5
2.1. Select protective surfacing	5
2.2. Poured-in-place surfaces or pre-manufactured rubber tiles	5
2.3. Positioning	5
3.0. Operating Instructions	6
4.0. Pre-assembly	6
4.2. Parts checklist	7
5.0. Assembly instructions – Swing Set Frame	8
6.0. Product registration	13
7.0. Half-price replacement parts	13
8.0. Warranty	13
8.1. Warranty periods	13
8.2. Inclusions	14
8.3. Exclusions	14
8.4. Warranty Claims	14
8.5. Australian Consumer Law	15
9.0. Missing parts	15

Responsibility rests with the owner and supervisors of the play set to make sure that all users are aware of the practices specified in this manual.

1.0. Care and maintenance

Improper maintenance or lack of care can lead to your product deteriorating earlier than expected and causing injury. Please follow these instructions to ensure that your product lasts for as long as possible.

At the beginning of each play session:

- Tighten all hardware.
- Check all protective coverings on bolts, pipes, edges, and corners.
 - Replace if they are loose, cracked, or missing.
- Check all moving parts – including swing seats, ropes, cables, and chains for wear, rust, or other deterioration.
 - Replace as needed.
- Check metal parts for rust.
 - If found, sand and repaint using a non lead-based paint meeting the requirements of 16 CFR 1303.
- Reinstall any plastic parts, such as swing seats or any other items, that were removed.
- Rake and check depth of loose fill protective surfacing materials to prevent compaction and to maintain appropriate depth.
 - Replace as necessary.

Twice a month during play session:

- Tighten all hardware.
- Check all protective coverings on bolts, pipes, edges, and corners.
 - Replace if they are loose, cracked, or missing.
- Rake and check depth of loose fill protective surfacing materials to prevent compaction and to maintain appropriate depth.
 - Replace as necessary.

Once a month during play session:

- Check all moving parts including swing seats, ropes, cables, and chains for wear, rust, or other deterioration.
 - Replace as needed.

At the end of each play session:

- Remove plastic and textile swings and store in a cool, dry place.
- Rake and check depth of loose fill protective surfacing materials to prevent compaction and to maintain appropriate depth.
 - Replace as necessary.

Owners shall be responsible for maintaining the legibility of the warning labels.

Disassemble and dispose of the equipment when it is no longer safe to use. Ensure that no unreasonable hazards exist at the time the equipment is discarded.

Save this instruction and information sheet for future reference, in the event that the manufacturer has to be contacted.

2.0. Safety Information

Maximum Swing fall height: 2,226 mm (88 in.)

United States Consumer Product Safety Commission's (USCPSC) Outdoor Home Playground Safety Handbook. See below:

2.1. Select Protective Surfacing

One of the most important things you can do to reduce the likelihood of serious head injuries is to install shock-absorbing protective surfacing under and around your play equipment. The protective surfacing should be applied to a depth that is suitable for the equipment height in accordance with ASTM Specification F1292. There are different types of surfacing to choose from; whichever product you select, follow these guidelines:

2.1.1. Maintain a minimum depth of 9 in. (229 mm) of loose-fill materials such as wood mulch/chips, engineered wood fiber (EWF), or shredded/recycled rubber mulch for equipment up to 96 in. (2438 mm) high; and 9 in. (229 mm) of sand or pea gravel for equipment up to 60 in. (1524 mm) high.

NOTE: *An initial fill level of 12 in. (305 mm) will compress to about a 9 in. (229 mm) depth of surfacing over time. The surfacing will also compact, displace, and settle, and should be periodically refilled to maintain at least a 9 in. (229 mm) depth.*

2.1.2. Use a minimum of 6 in. (152 mm) of protective surfacing for play equipment less than 48 in. (1219 mm) in height. If maintained properly, this should be adequate. (At depths less than 6 in. (152 mm), the protective material is too easily displaced or compacted.)

NOTE: *Do not install home playground equipment over concrete, asphalt, or any other hard surface. A fall onto a hard surface can result in serious injury to the equipment user. Grass and dirt are not considered protective surfacing because wear and environmental factors can reduce their shock absorbing effectiveness. Carpeting and thin mats are generally not adequate protective surfacing. Ground level equipment – such as a sandbox, activity wall, playhouse or other equipment that has no elevated play surface – does not need any protective surfacing.*

2.1.3. Use containment, such as digging out around the perimeter and/or lining the perimeter with landscape edging. Don't forget to account for water drainage.

2.1.3.1. Check and maintain the depth of the loose-fill surfacing material. To maintain the right amount of loose-fill materials, mark the correct level on play equipment support posts. That way you can easily see when to replenish and/or redistribute the surfacing.

2.1.3.2. Do not install loose fill surfacing over hard surfaces such as concrete or asphalt.

2.2. Poured-In-Place Surfaces or Pre-Manufactured Rubber Tiles

You may be interested in using surfacing other than loose-fill materials, like rubber tiles or poured-in-place surfaces.

2.2.1. Installations of these surfaces generally require a professional and are not "do-it-yourself" projects.

2.2.2. Review surface specifications before purchasing this type of surfacing. Ask the installer/manufacture for a report showing that the product has been tested to the following safety standard: ASTM F1292 Standard Specification for Impact Attenuation of Surfacing Materials within the Use Zone of Playground Equipment. This report should show the specific height for which the surface is intended to protect against serious head injury. This height should be equal to or greater than the fall height – vertical distance between a designated play surface (elevated surface for standing, sitting, or climbing) and the protective surfacing below – of your play equipment.

2.2.3. Check the protective surfacing frequently for wear.

2.3. Placement

Proper placement and maintenance of protective surfacing is essential. Be sure to:

2.3.1. Extend surfacing at least 72 in. (1829 mm) from the equipment in all directions.

2.3.2. For to-and-fro swings, extend protective surfacing in front of and behind the swing to a distance equal to twice the height of the top bar from which the swing is suspended.

2.3.3. For 360° swings, extend surfacing in a circle whose radius is equal to the height of the suspending chain or rope, plus 6 ft in all directions.

3.0. Operating Instructions

Observing the following statements and warnings reduces the likelihood of serious or fatal injury:

- Number of occupants: One [1]
- Maximum weight of occupants: 50 kg (110 lb) .
- Recommend: Adult supervision for children of all ages.
- **Warning:** Instruct children not to walk close to, in front of, behind, or between moving items.
- **Warning:** Instruct children not to twist swing chains or ropes or loop them over the top support bar. This may reduce the strength of the chain or rope.
- **Warning:** Instruct children to avoid swinging empty seats.
- **Warning:** Teach children to sit in the center of the swings, with their full weight on the seats.
- **Warning:** Instruct children not to use the equipment in a manner other than intended.
- **Warning:** Instruct children not to get off equipment while it is in motion.
- **Warning:** Don't allow children to wear inappropriate items, such as – but not limited to – loose fitting clothing, hood and neck drawstrings, scarves, cord-connected items, capes and ponchos. These items can cause death by strangulation.
- **Warning:** Instruct children not to climb when the equipment is wet.
- **Warning:** Check the openings between rollers and sliding surfaces of roller slides for foreign materials that could be potentially hazardous to users.
- **Warning:** Verify that suspended climbing ropes, chain, or cable are secured at both ends.
- **Warning:** Verify that suspended climbing ropes, chain, or cable cannot be looped back on itself.
- **Warning:** Instruct children not to attach items to the playground equipment that are not specifically designed for use with the equipment, such as – but not limited to – jump ropes, clothesline, pet leashes, cables and chain, as they may cause a strangulation hazard.
- **Warning:** Instruct children to remove their bike or other sports helmet before playing on the playground equipment.
- **Warning:** Dress children with well-fitting and full foot-enclosing footwear. Examples of inappropriate footwear are clogs, flip flops, and sandals.

4.0. Pre-assembly

- Place the equipment on level ground and in a well-lit area, no less than 1.8 m (6 ft) from any structure or obstruction – such as a fence, garage, house, overhanging branches, laundry lines, or electrical wires.
- Avoid installing over concrete, asphalt, packed earth, grass, carpet, or any other hard surface. A fall onto a hard surface can result in serious injury or death to the equipment user.
- Ensure that your chosen surface allows the swing set to be firmly embedded with the included Anchor Kit.
- Check that you have all parts required for assembly.
- **Warning:** Lock nuts and bolts securely.
- **Warning:** Children must not use the equipment until properly installed.

4.1. Parts checklist – Swing Set frame

ALL SIZES:

2X FRAME – BOX A

1X FRAME – BOX B

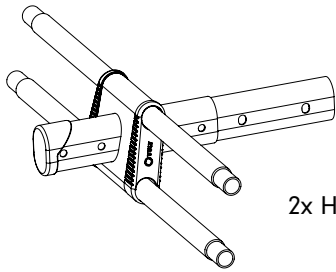

2x H Joiner

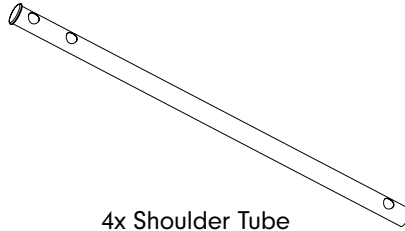

4x Shoulder Tube

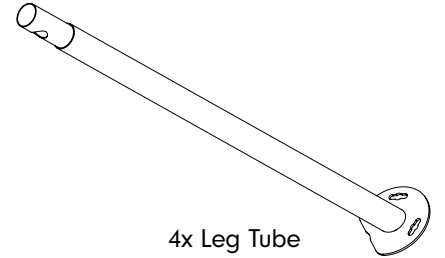

4x Leg Tube

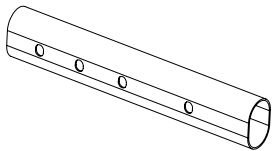

2x End Joiner

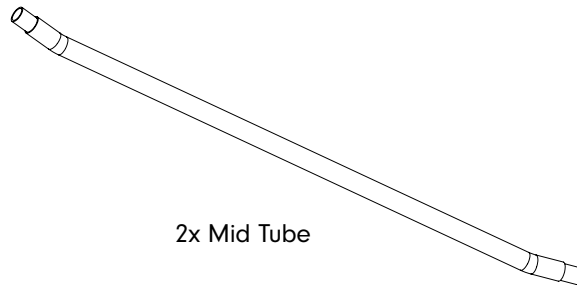

2x Mid Tube

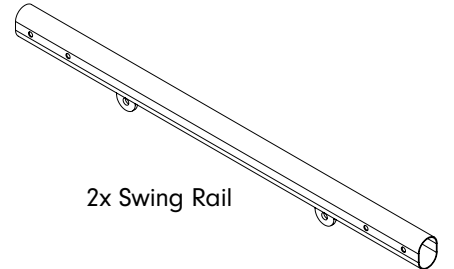

2x Swing Rail

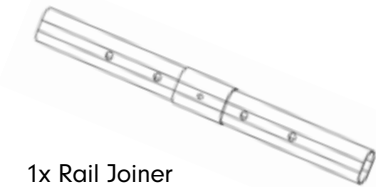

1x Rail Joiner

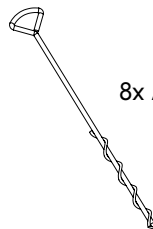

8x Anchor



1x Bolt Kit

Upsize Kit

If you purchased a size with more than 2 swing slots, you will have **1x Upsize Kit (contents below) swing slot.**

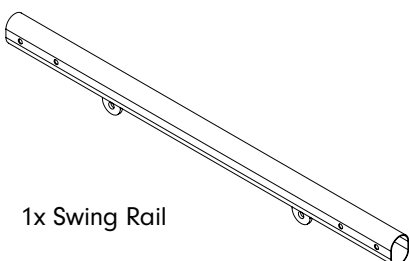

1x Swing Rail



1x Rail Joiner



1x Bolt Kit

5.0. Assembly instructions – Swing Set frame

Remove all parts from the packaging, and lay out the components on the ground.

ENSURE THAT AS YOU FOLLOW THESE INSTRUCTIONS, YOU FIRMLY SECURE ALL PARTS WITH NUTS AND BOLTS.

IMPORTANT: WHEN LOCKING TOGETHER FRAME BOLTS, ENSURE THAT YOU INSERT THE LONG BOLTS ALTERNATELY ON EITHER SIDE.

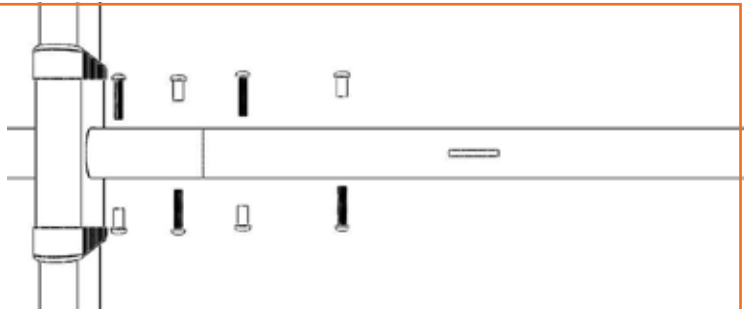

STEP | 1

Insert an End Joiner into the centre of an H Joiner.
Lock them together with Frame Bolts.

Repeat for the remaining End Joiner and H Joiner pair.

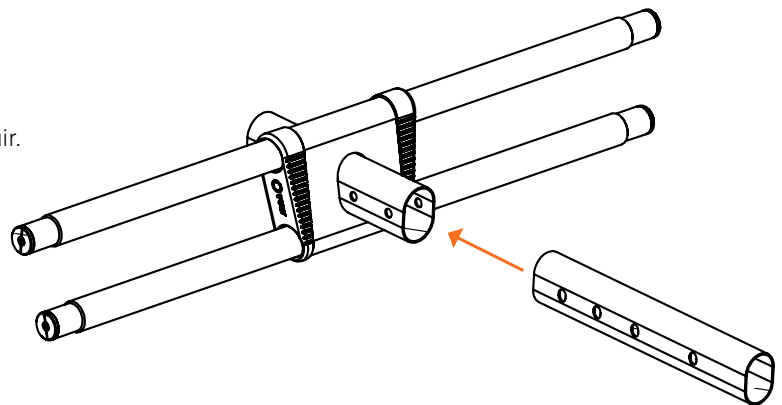

Remember: Lay all parts face-up on the ground, as shown. You will start by assembling the swing set upside down.

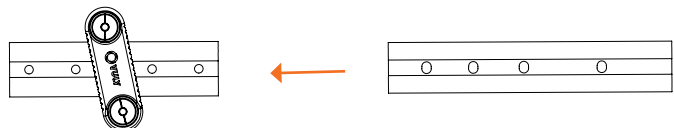

STEP | 2

- A. Insert a Swing Rail into each of the two End Joiner and H Joiner pairs. Lock them together with Frame Bolts.

TO CREATE 2 SWING SLOTS:

- B. Insert one shared Swing Joiner into the ends of both Swing Rails. Lock them together with Frame Bolts.

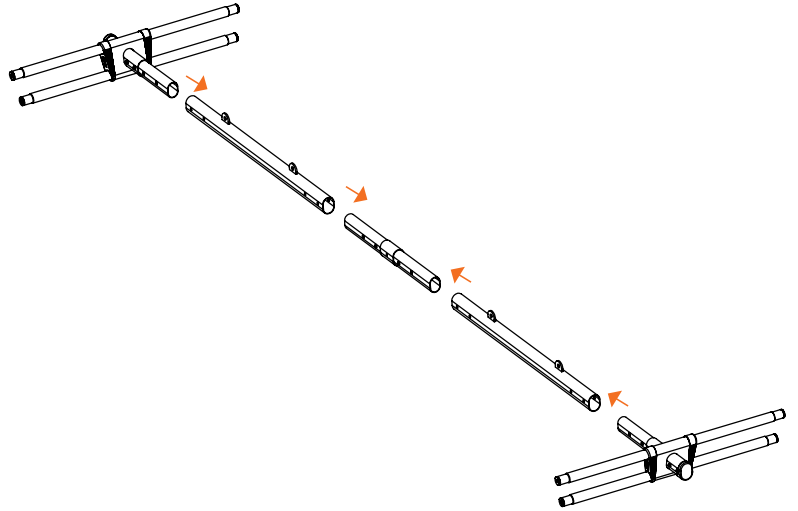

TO CREATE 3 SWING SLOTS:

(requires 1x Upsize Kit)

- B. Insert a Swing Joiner into each end of both Swing Rails.
- C. Insert the remaining Swing Rail between these two Swing Joiners. Lock them together with Frame Bolts.

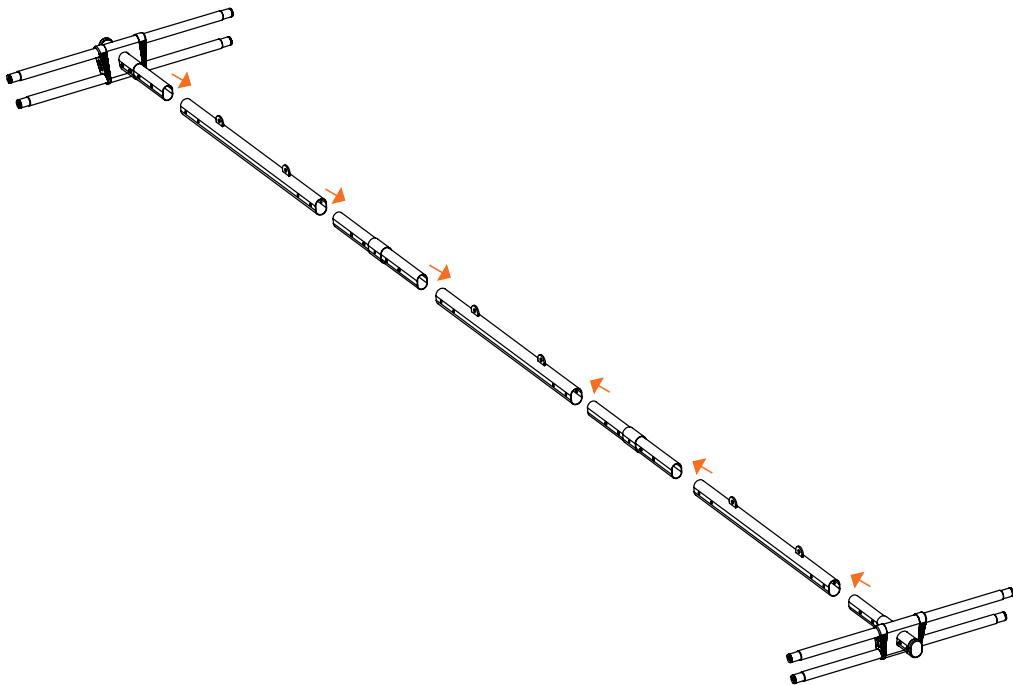

WARNING:



Never use more than one Upsize Kit to create more than three swing slots side-by-side on your frame. Doing so would dramatically reduce the structural integrity of the design and may cause injury.

STEP | 3

Insert a Leg Tube into the bottom of a Shoulder Tube.

Repeat for the three remaining Shoulder Tube and Leg Tube pairs.

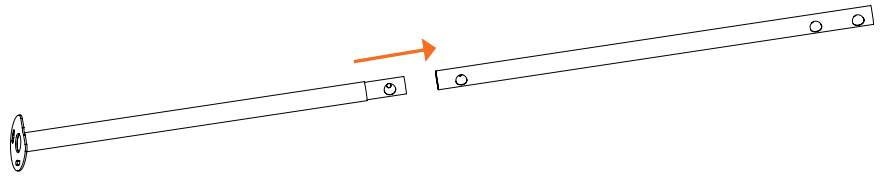

STEP | 4

Insert the top of a Shoulder Tube and Leg Tube pair into the prongs on the side of an H Joiner. Lock them together with Locking Bolts.

Note: Ensure that the legs kick outwards and that, when you flip the unit over, the left and right legs will be on the correct sides.

STEP | 5

Insert a Mid Tube into the inward-facing hole on the connected Shoulder Tube. Lock them together with Frame Bolts.

Note: Ensure that the Mid Tube bends inwards.

STEP | 6

A. Attach the remaining Shoulder Tube and Leg Tube pair to the other side of the H Joiner and Mid Tube. Lock them together with Locking Bolts.

Note: Ensure that the legs kick outwards and that, when you flip the unit over, the left and right legs will be on the correct sides.

B. Repeat Steps 4-6A on the other side of the swing set.

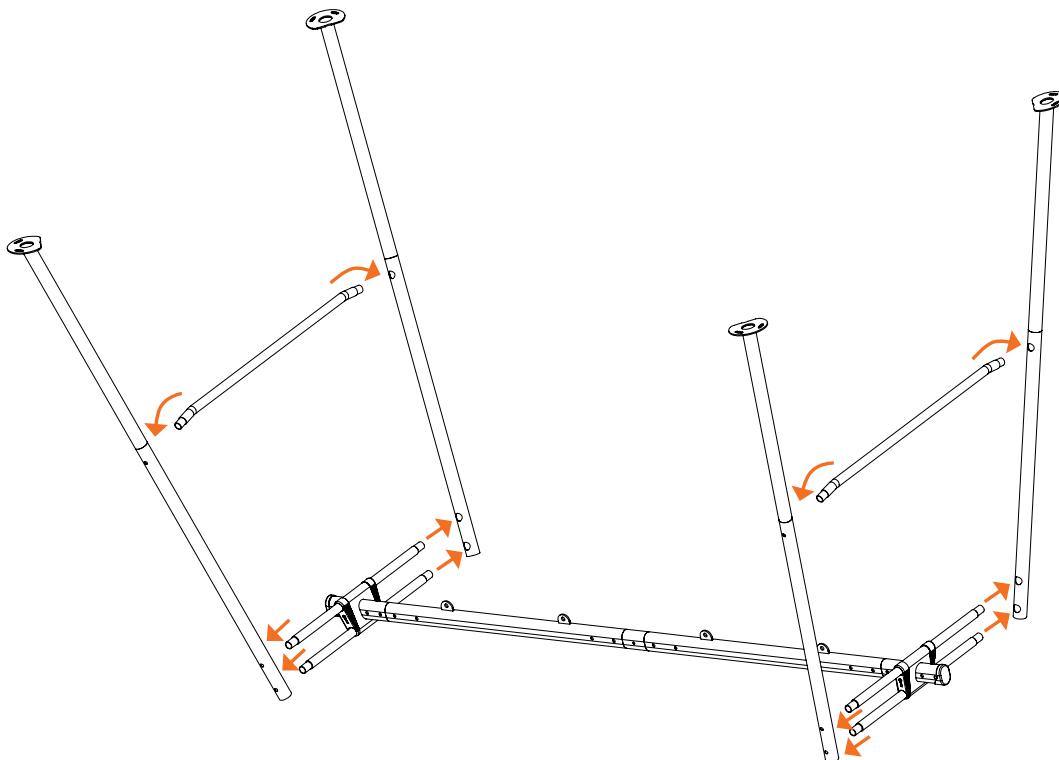

STEP | 7

Flip the completed swing set frame upright.

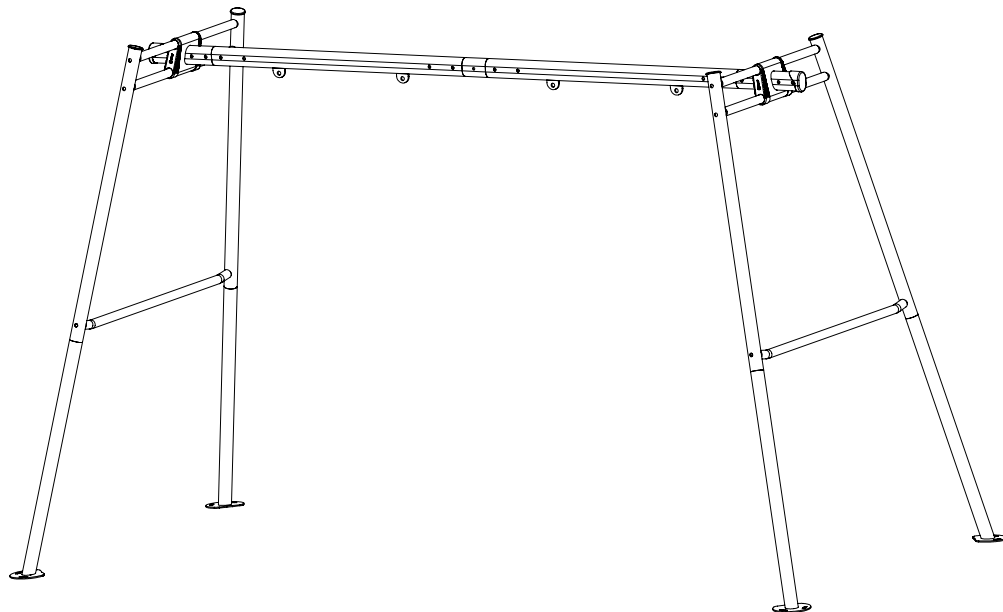

STEP | 8 SHADE COVER

Skip this section if you do not wish to attach your Shade Cover.

STEP | 8 A

Lay out the Shade cover atop your partially completed frame.

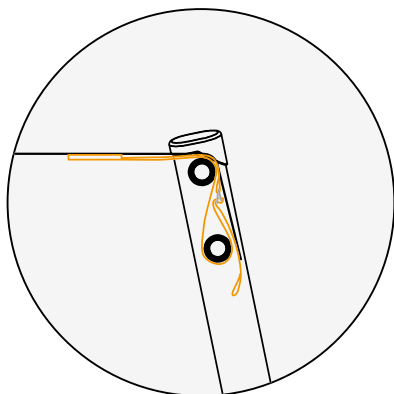
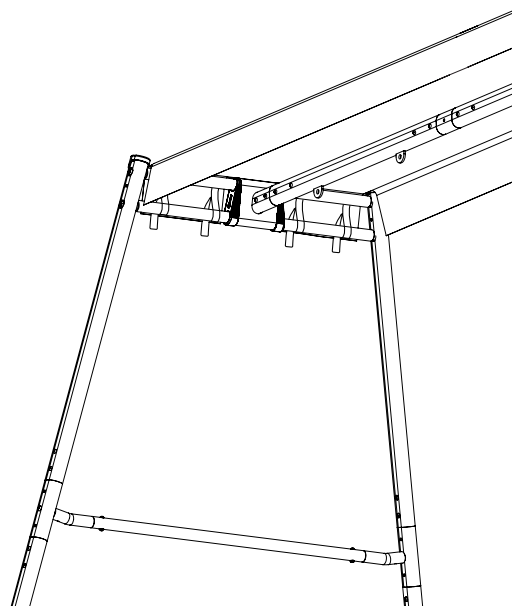

STEP | 8 B

Pull the two straps at both ends of the swing set around their respective H Joiners. Tighten them through the loops on the straps until the Shade Cover is taut.

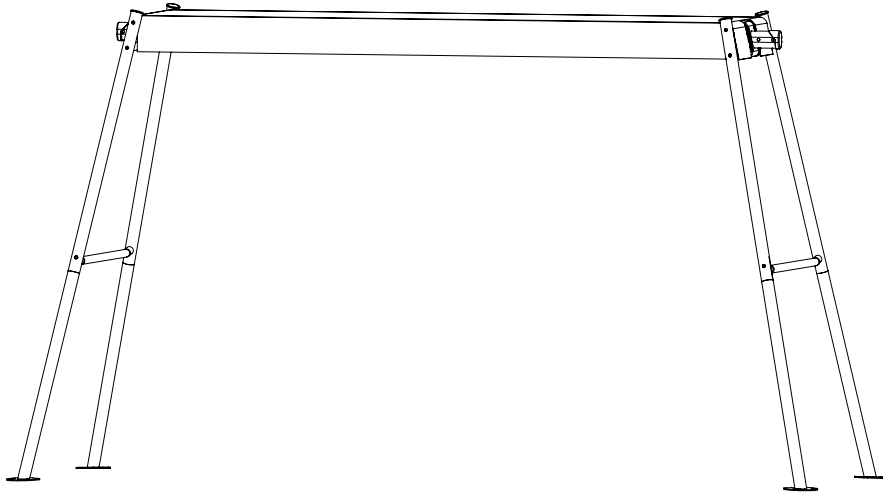

CONGRATULATIONS!

You have assembled your swing set frame.
See your Swing instructions to attach your chosen swings.



6.0. Product registration

To access the Half-Price Parts for Life programme or to lodge a Warranty Claim, customers must ensure that their Vuly product is registered with Vuly.

Customers who purchase directly from Vuly (through **VulyPlay.com**, at the Vuly Showroom or over the phone) automatically have their product registered.

Customers who purchase through an Authorised Reseller must register their product by visiting VulyPlay.com/Support and completing the form with a proof of purchase.

7.0. Half-price replacement parts

Vuly offers half-price replacement parts to all customers for the lifetime of their purchase through the Half-Price Parts for Life programme.

This programme is subject to change at any time, and it is only available to customers who have purchased either through an Authorised Reseller or directly through Vuly.

Half-Price Parts for Life is only available to customers who wish to replace parts that are core components of their.

For the swing sets, these parts include the following elements of the frame:

- Tubes
- Joiners
- Rails

The programme does not extend to individual Swings, Shade Covers or accessories.

8.0. Warranty

All Vuly products are sold with a manufacturing warranty, which assures that the item is free of defects in workmanship and materials ("warranty").

8.1. Warranty periods

Warranty periods do not reset for any reason, unless the customer purchases a new product. In this case, that particular item will be covered by its own warranty period. It does not affect – nor will it increase – warranty periods for other purchased items.

Warranty periods always commence from the date of item delivery.

This warranty is for use under normal conditions, and it applies for:

SWING SETS

- 60 months [5 years] to the frame components.
- 36 months [2 years] to Swings.

ACCESSORIES

- 12 months [1 year] to purchased accessories or attachments not received during a promotional period.
- 3 months to any items received at no cost as part of a promotion – e.g. 'Free Shade Cover'.

The customer may extend the standard 12-month [1 year] warranty to 36 months [3 years], if they purchase an extended warranty within 7 days of their delivery date.

8.1.1. Second-hand purchases

Vuly warranties apply only for the original purchaser, to a product purchased from Vuly Play or an Authorised Reseller. On-selling a Vuly product voids and all warranties.

8.2. Inclusions

This warranty covers **manufacturing faults** and **defects only**.

If a product is damaged or rendered unsafe as a result of a departure from its design specifications during production, this constitutes a manufacturing fault or defect.

This may occur if – for example – use of incorrect textiles during manufacturing causes a Swing Cloth to disintegrate, or if improper welding produces an unstable Frame.

8.3. Exclusions

8.3.1. Damage through wear and tear

This warranty does not extend to normal wear and tear of the product. This may include, but is not limited to:

- Rusting or scratching of steel components,
- UV deterioration of textile components.

As outdoor products that are actively used, swing sets and their accessories will experience wear and tear over time.

8.3.2. Damage through weather conditions

Damage to the product that results from weather events – such as rain or wind – are not covered under the warranty. Vuly suggests that you contact your home and contents insurer if your product is damaged by such events.

8.3.3. Damage through improper installation

This warranty does not extend to any failure of the product caused by installation not in accordance with the Vuly Manual. Customers must assemble their Vuly product by following carefully the Installation section of their Vuly Manual.

Furthermore, the warranty does not cover installation provided by a third-party assembly service. It is the customer's responsibility to check all boxes and confirm that all components are included in the correct condition before installing.

8.3.4. Damage through insufficient care or maintenance

This warranty does not extend to accelerated decay of the product caused by poor care or maintenance. It is essential that customers regularly check, and follow the advice of, the Care and Maintenance section of their Vuly Manual to ensure that their product lasts as long as possible.

8.3.5. Damage through inappropriate use

This warranty will be void if the product is used for any other activity besides those for which it was intended, or used in any way that is unadvised in this Manual. Vuly products constitute recreational outdoor products and accessories for

such products. They are not intended for professional use.

Any evidence that inappropriate actions that have led to product failure will not be covered by the warranty. Similarly, replacement parts or repairs needed to mend such damage will not be covered under the warranty.

8.3.6. Damage through salt water proximity

This warranty (on steel components, specifically) will be reduced by 50% where the Vuly product is assembled within 1.6 km of a salt water environment or where it is subject to ocean spray.

8.3.7. Personal Injury

The warranty does not cover personal injury or losses due to any of the above: wear and tear, weather conditions, inappropriate installation, insufficient care or maintenance or inappropriate use, nor does it cover damage due to negligence or accidents.

8.3.8. Installation

This warranty does not cover any installation service. If a customer pays for installation of their Vuly product at the time of purchase, this is a one-time service only. The customer may not claim installation costs for any replacement parts.

8.4. Warranty Claims

If a customer believes that a Vuly product is faulty or defective, they must discontinue use and submit a Warranty Claim.

A customer must not attempt to use a product if any part is faulty or defective, as it may be dangerous. Any damage that the user causes as a result of using faulty or defective products will lead to voiding of the warranty.

8.4.1. Making a Warranty Claim

To fulfill a warranty claim, a customer must submit an online Warranty Claim at VulyPlay.com/Support.

Submitting the online Warranty Claim form requires the customer to provide:

- Details of their purchase – including date,
- Batch number,
- Clear photographic evidence of the manufacturing fault or defect.

If the customer does not provide all details that the form requires, their Warranty Claim will not be assessed.

Vuly may take up to 7 days to process Warranty Claims upon a completed submission. It may take a further 7 days for replacement parts to reach the customer.

8.4.2. Successful Warranty Claims

If Vuly accepts a customer's Warranty Claim, Vuly will replace the faulty or defective parts, not offer refunds.

Successful Warranty Claims lodged within 60 days of the delivery date:

Vuly will replace the damaged parts free of charge. Vuly will also cover any costs associated with shipping the replacement part.

Successful Warranty Claims lodged after 60 days of the delivery date:

Vuly will replace the damaged parts free of charge. The customer must cover any costs associated with shipping the replacement part.

8.4.3. Walk-in Warranty Claims

If a customer wishes to make a Warranty Claim while on the Vuly premises, they must first submit an online Warranty Claim at VulyPlay.com/Support - providing all required details.

8.4.4. Refunds

In all instances of successful warranty claims, Vuly offers replacements parts only. Vuly provides refunds only at their discretion. Any refunds granted to the customer exclude third-party fees, such as assembly services and credit card surcharges.

8.4.5 Claiming on non-Vuly products

Products sold alongside Vuly that are not Vuly-branded are subject to the warranties provided by the companies that supply them. The customer must contact these external companies to make a warranty claim; Vuly itself will not assess claims made against non-Vuly products.

8.5. Australian Consumer Law

Our Goods come with guarantees that cannot be excluded under the Australian Consumer Law. You are entitled to a replacement or refund for a major failure and for compensation for any other reasonably foreseeable loss or damage. You are also entitled to have the Goods repaired or replaced if the Goods fail to be of acceptable quality and the failure does not amount to a major failure.

9.0. Missing parts

If a customer believes that a Vuly product does not include all necessary parts, they must immediately lodge a Missing Parts Claim at VulyPlay.com/Support.

A customer must not attempt to use a product if any part is incomplete, as it may be dangerous. Any damage that the user causes as a result of using incomplete products will lead to voiding of the warranty.

Vuly products are delivered to Vuly warehouses prepackaged; we are unable to check the boxes prior to delivery to ensure that they contain all the required parts. While the missing part rate during packing is very low, some parts may also fall out in transit due to small, unintentional tears in their boxes.



vulyplay.com