



TODDLER SWING

MANUAL



Visit www.vulyplay.com/install
for step by step video instructions, or scan this QR code



**ADULT SUPERVISION IS REQUIRED AT ALL TIMES WHILST EQUIPMENT IS IN USE.
VULY CARES ABOUT SAFETY.**



WARNING:

To reduce the risk of injury while using the system, enforce the following:

- Not suitable for children under 18 months old.
- Only for domestic and outdoor use.
- Maximum user weight per swing station – 80 kg (175 lb) .
- Maximum combined user weight per swing set frame – 150 kg (330 lb).
- Adult assembly required.
- Adult supervision required at all times.
- Ensure that the Swing Set is secured with anchors or bolts before use.
- Risk of strangulation or death due to items restricting airways, becoming entangled or entrapped by the equipment.

Care and Maintenance

Improper maintenance or lack of care can lead to your swing set deteriorating earlier than expected and causing injury.

Please follow these instructions to ensure that your swing set lasts for as long as possible.

At the beginning of each play session:

- Tighten all hardware.
- Check all protective coverings on bolts, pipes, edges, and corners.

Replace if they are loose, cracked, or missing.

- Check all moving parts – including swing seats, ropes, cables, and chains for wear, rust, or other deterioration.

Replace as needed.

- Check metal parts for rust.

If found, sand and repaint using a non lead-based paint meeting the requirements of 16 CFR 1303.

- Reinstall any plastic parts, such as swing seats or any other items, that were removed.

- Rake and check depth of loose fill protective surfacing materials to prevent compaction and to maintain appropriate depth.

Replace as necessary.

Twice a month during play session:

- Tighten all hardware.
- Check all protective coverings on bolts, pipes, edges, and corners.

Replace if they are loose, cracked, or missing.



RISK WARNING:

The use of the Product involves a significant risk of participants suffering personal injury including the possibility of serious injuries, permanent disability or death. All participants who engage in activities with the Product do so at their own risk.

- Rake and check depth of loose fill protective surfacing materials to prevent compaction and to maintain appropriate depth.

Replace as necessary.

Once a month during play session:

- Check all moving parts including swing seats, ropes, cables, and chains for wear, rust, or other deterioration.

Replace as needed.

At the end of each play session:

- Remove plastic and textile swings and store in a cool, dry place.

- Rake and check depth of loose fill protective surfacing materials to prevent compaction and to maintain appropriate depth.

Replace as necessary.

Owners shall be responsible for maintaining the legibility of the warning labels.

Disassemble and dispose of the equipment when it is no longer safe to use. Ensure that no unreasonable hazards exist at the time the equipment is discarded.

Replace any worn, deteriorated, defective or missing parts immediately and only through Vuly.

Save this instruction and information sheet for future reference, in the event that the manufacturer has to be contacted.

Safety Information

Maximum Swing fall height: 2,226 mm (88 in.)

United States Consumer Product Safety Commission's (USCPSC) Outdoor Home Playground Safety Handbook. See below:

2.1. Select Protective Surfacing

One of the most important things you can do to reduce the likelihood of serious head injuries is to install shock-absorbing protective surfacing under and around your play equipment. The protective surfacing should be applied to a depth that is suitable for the equipment height in accordance with ASTM Specification F1292. There are different types of surfacing to choose from; whichever product you select, follow these guidelines:

2.1.1. Maintain a minimum depth of 9 in. (229 mm) of loose-fill materials such as wood mulch/chips, engineered wood fiber (EWF), or shredded/recycled rubber mulch for equipment up to 96 in. (2438 mm) high; and 9 in. (229 mm) of sand or pea gravel for equipment up to 60 in. (1524 mm) high.

NOTE: *An initial fill level of 12 in. (305 mm) will compress to about a 9 in. (229 mm) depth of surfacing over time. The surfacing will also compact, displace, and settle, and should be periodically refilled to maintain at least a 9 in. (229 mm) depth.*

2.1.2. Use a minimum of 6 in. (152 mm) of protective surfacing for play equipment less than 48 in. (1219 mm) in height. If maintained properly, this should be adequate. (At depths less than 6 in. (152 mm), the protective material is too easily displaced or compacted)

NOTE: *Do not install home playground equipment over concrete, asphalt, or any other hard surface. A fall onto a hard surface can result in serious injury to the equipment user. Grass and dirt are not considered protective surfacing because wear and environmental factors can reduce their shock absorbing effectiveness. Carpeting and thin mats are generally not adequate protective surfacing. Ground level equipment – such as a sandbox, activity wall, playhouse or other equipment that has no elevated play surface – does not need any protective surfacing.*

2.1.3. Use containment, such as digging out around the perimeter and/or lining the perimeter with landscape edging. Don't forget to account for water drainage.

2.1.3.1. Check and maintain the depth of the loose-fill surfacing material. To maintain the right amount of loose-fill materials, mark the correct level on play equipment

support posts. That way you can easily see when to replenish and/or redistribute the surfacing.

2.1.3.2. Do not install loose fill surfacing over hard surfaces such as concrete or asphalt.

2.2. Poured-In-Place Surfaces or Pre-Manufactured Rubber Tiles

You may be interested in using surfacing other than loose-fill materials, like rubber tiles or poured-in-place surfaces.

2.2.1. Installations of these surfaces generally require a professional and are not "do-it-yourself" projects.

2.2.2. Review surface specifications before purchasing this type of surfacing. Ask the installer/manufacturer for a report showing that the product has been tested to the following safety standard: ASTM F1292 Standard Specification for Impact Attenuation of Surfacing Materials within the Use Zone of Playground Equipment. This report should show the specific height for which the surface is intended to protect against serious head injury. This height should be equal to or greater than the fall height – vertical distance between a designated play surface (elevated surface for standing, sitting, or climbing) and the protective surfacing below – of your play equipment.

2.2.3. Check the protective surfacing frequently for wear.

2.3. Placement

Proper placement and maintenance of protective surfacing is essential. Be sure to:

2.3.1. Extend surfacing at least 72 in. (1829 mm) from the equipment in all directions.

2.3.2. For to-and-fro swings, extend protective surfacing in front of and behind the swing to a distance equal to twice the height of the top bar from which the swing is suspended.

2.3.3. For 360° swings, extend surfacing in a circle whose radius is equal to the height of the suspending chain or rope, plus 6 ft in all directions.

Operating and Pre-assembly Instructions

Observing the following statements and warnings reduces the likelihood of serious or fatal injury:

- Number of occupants: One [1]
 - The system may become hot enough under direct sunlight and cause burning injuries.
 - Check all coverings and bolts for sharp edges and replaced when required.
 - Ensure active and competent adult supervision at all times while children are using the system.
 - Do not use in strong wind conditions or wet weather, and keep the system secure.
 - Exercise caution at heights.
 - **Warning:** Instruct children not to walk close to, in front of, behind, or between moving items.
 - **Warning:** Instruct children not to twist swing chains or ropes or loop them over the top support bar. This may reduce the strength of the chain or rope.
 - **Warning:** Instruct children to avoid swinging empty seats.
 - **Warning:** Teach children to sit in the center of the swings, with their full weight on the seats.
 - **Warning:** Instruct children not to use the equipment in a manner other than intended.
 - **Warning:** Instruct children not to get off equipment while it is in motion.
 - **Warning:** Don't allow children to wear inappropriate items, such as – but not limited to – loose fitting clothing, hood and neck drawstrings, scarves, cord-connected items, capes and ponchos. These items can cause death by strangulation.
 - **Warning:** Instruct children not to climb when the equipment is wet.
 - **Warning:** Check the openings between rollers and sliding surfaces of roller slides for foreign materials that could be potentially hazardous to users.
 - **Warning:** Verify that suspended climbing ropes, chain, or cable are secured at both ends and cannot be looped back on itself.
 - **Warning:** Instruct children not to attach items to the playground equipment that are not specifically designed for use with the equipment, such as – but not limited to – jump ropes, clothesline, pet leashes, cables and chain, as they may cause a strangulation hazard.
 - **Warning:** Instruct children to remove their bike or other sports helmet before playing on the playground equipment.
 - **Warning:** Dress children with well-fitting and full foot-enclosing footwear. Examples of inappropriate footwear are clogs, flip flops, and sandals.
 - Ensure that the system has been assembled by an adult, in accordance with the assembly instructions.
 - Avoid installing over concrete, asphalt, packed earth, grass, carpet, or any other hard surface. A fall onto a hard surface can result in serious injury or death to the equipment user.
 - Ensure that your chosen surface allows the swing set to be firmly embedded with the included Anchor Kit.
 - Check that you have all parts required for assembly.
 - **Warning:** Installation errors can cause falls from equipment, serious head injury or death.
 - **Warning:** Lock nuts and bolts securely.
 - **Warning:** Children must not use the equipment until properly installed.
-

360 Pro MAX



WARNING: Only one Carabina per connection point. **DO NOT** attach multiple Carabina together!

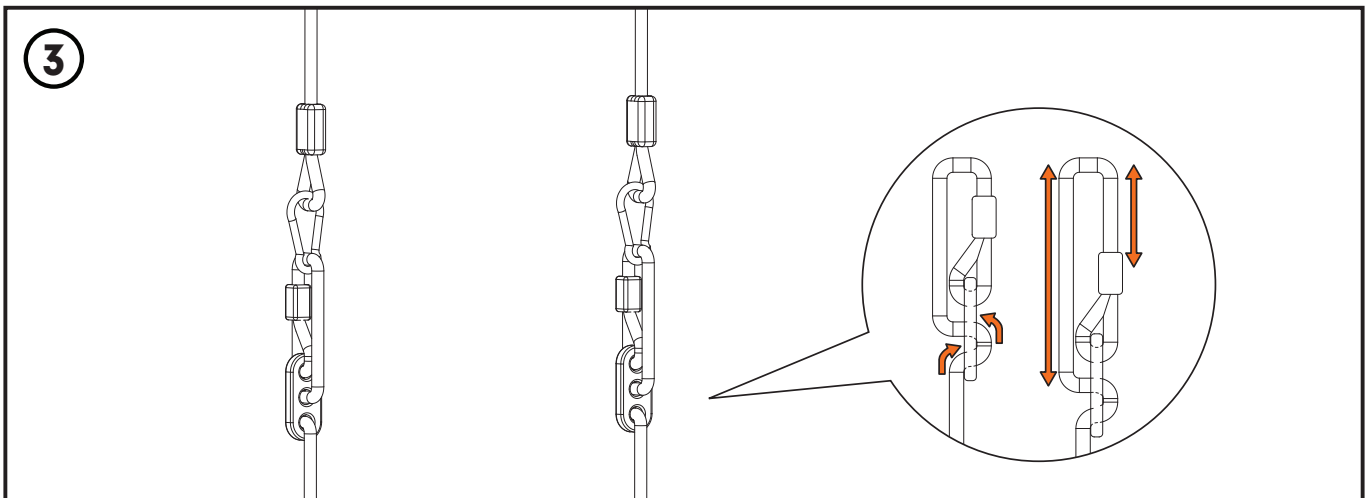
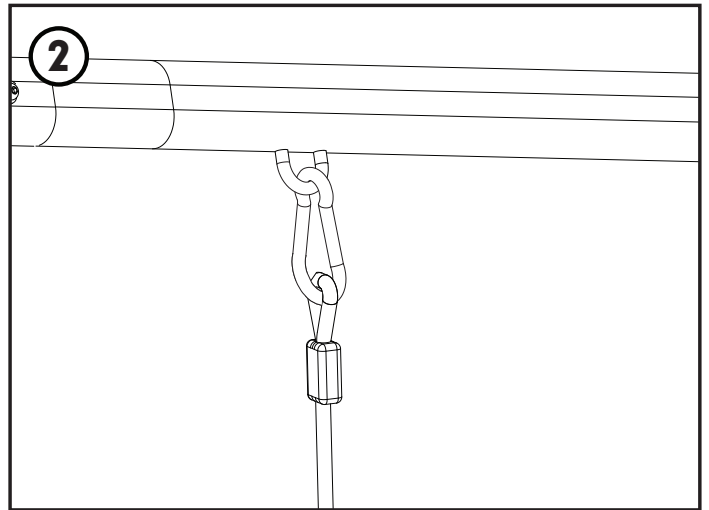
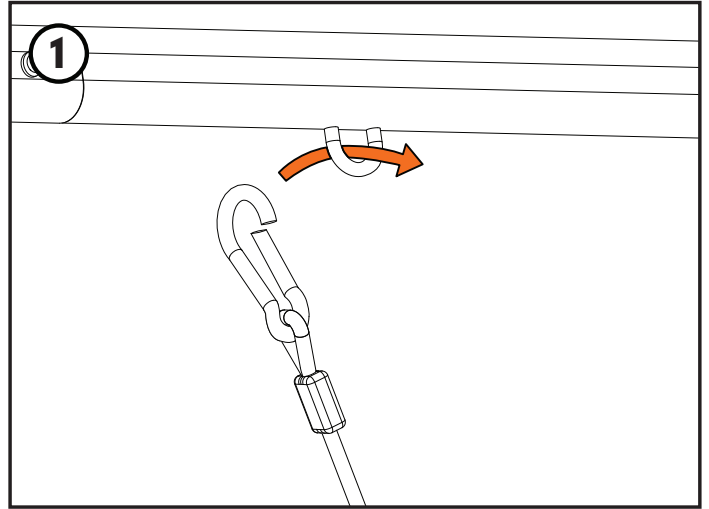
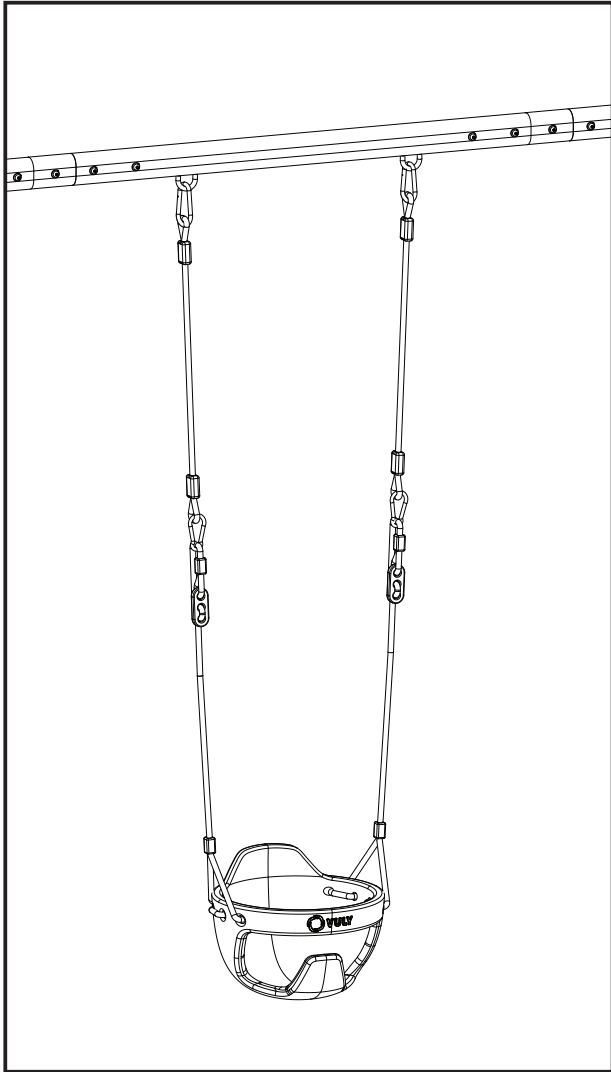

CONGRATULATIONS!

You have attached the Toddler Swing to your 360 Max Pro Swing Set.

Quest



WARNING: Only one Carabina per connection point. **DO NOT** attach multiple Carabina together!

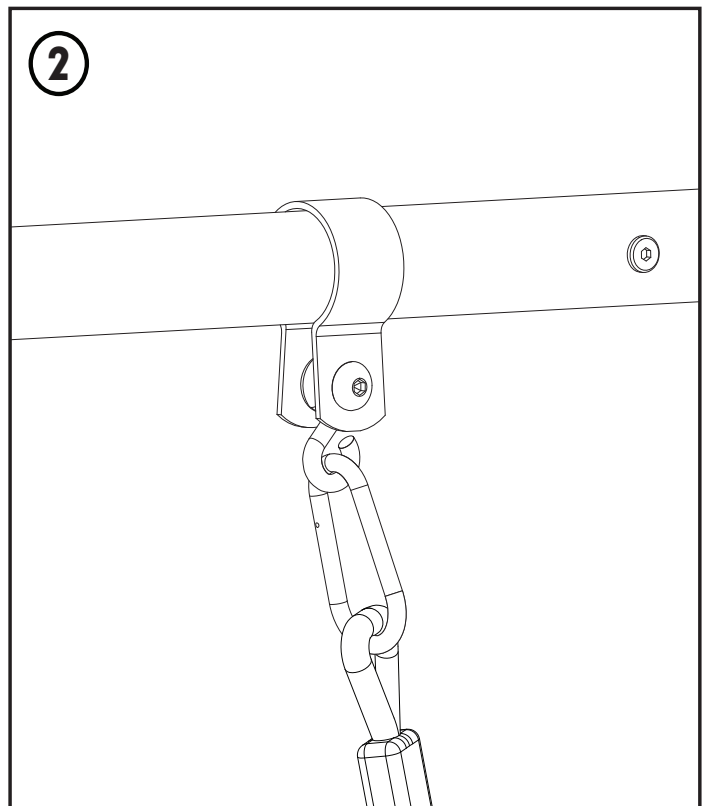
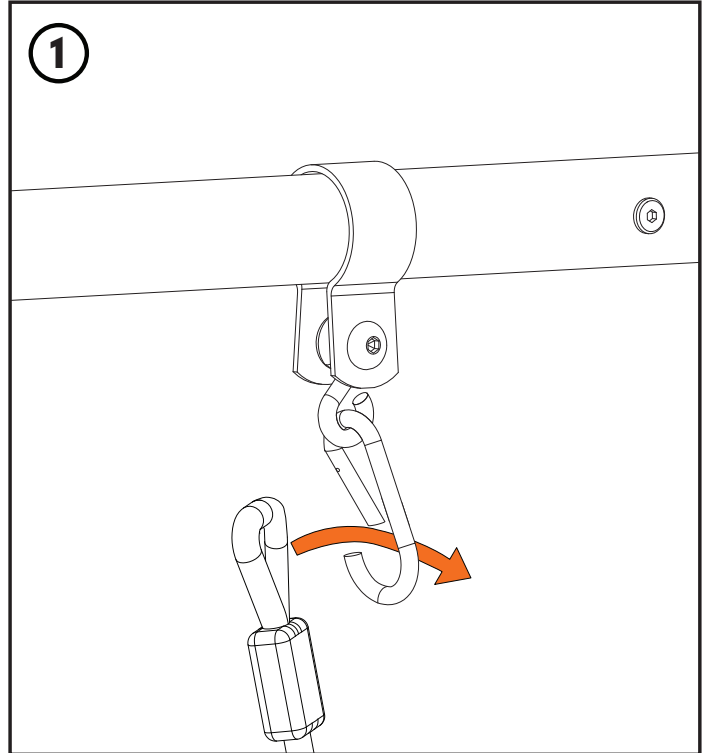
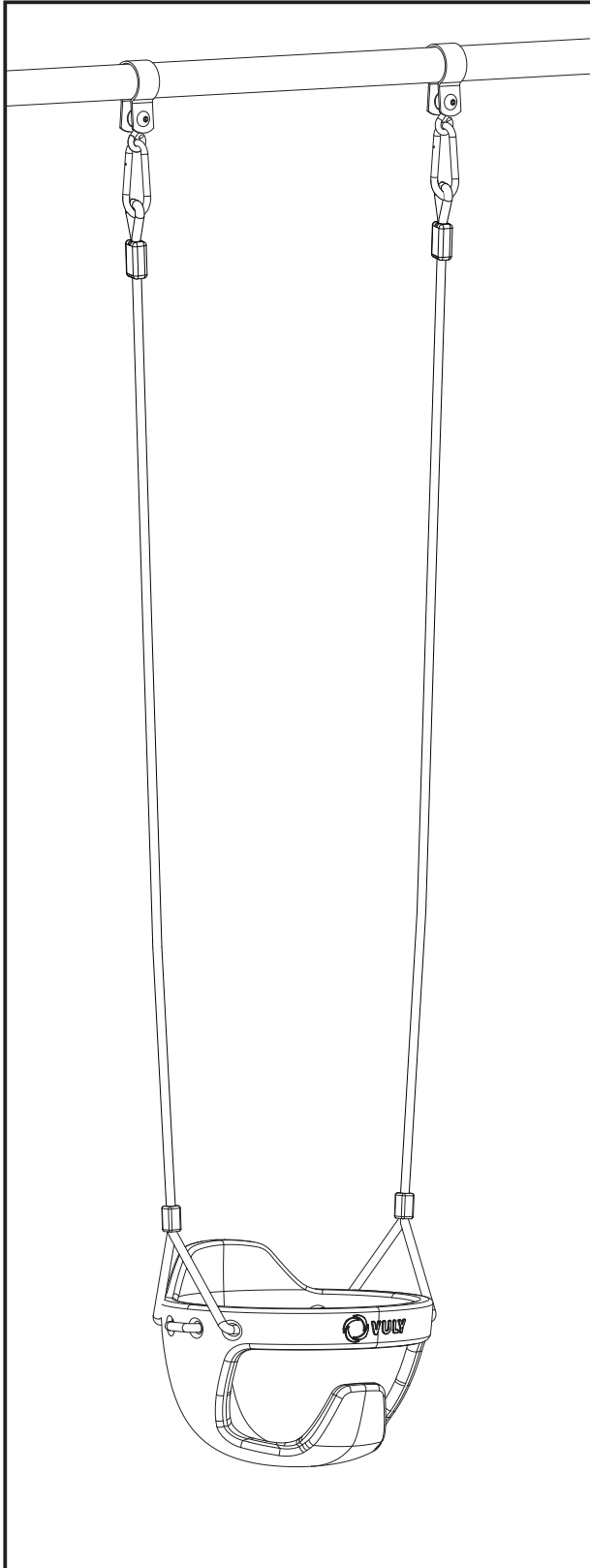

CONGRATULATIONS!

You have attached the Toddler Swing to your Quest.



See [VulyPlay.com/Terms](https://www.vuly.com/terms) for the most recent Vuly warranty policies, terms and conditions.