

INSTALLATION

PARTS LIST

- 1x Goal Mat
- 2x L-Tube
- 2x Side Tube
- 1x Bottom Tube

STEP | 1

Slide the Mid Tube of your swing set through the loops at the top of your Goal Mat.

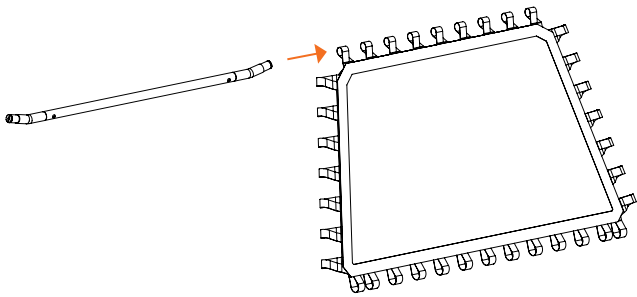

STEP | 2

Attach and secure the Mid Tube to your swing set, as per the Vuly Max Manual.

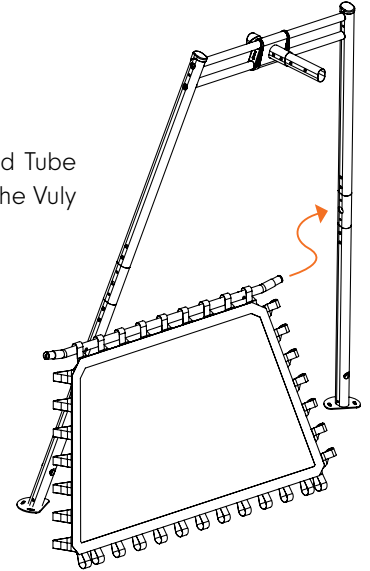

STEP | 3

Insert the Bottom Tube into the end of one L-Tube. Slide an L-Tube through either side of the loops at the bottom of your Goal Mat.

Note: Ensure that the small holes at the bend of the L-Tubes are facing upwards.

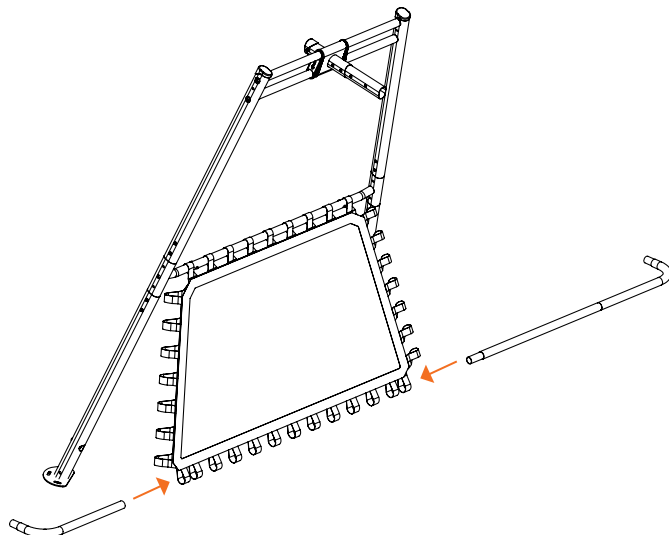

STEP | 4

Slide a Side Tube through the loops on either the side of your Goal Mat.

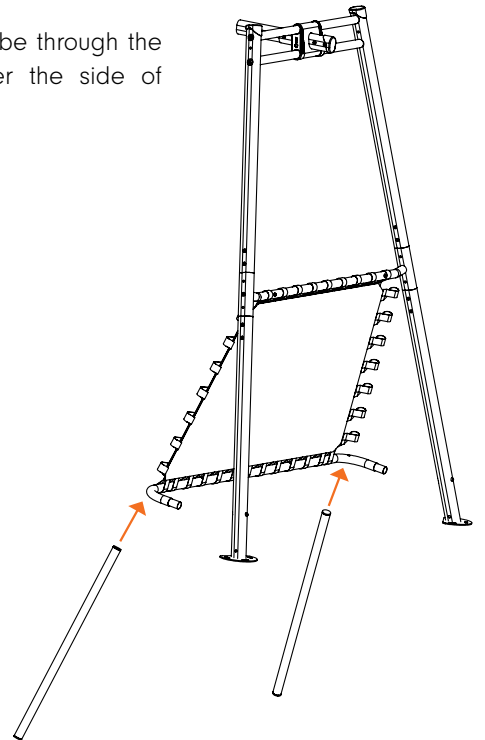

STEP | 5

- A. Push the pins at the tops of the Side Tubes through the holes in the Mid Joiners on your Vuly Max.

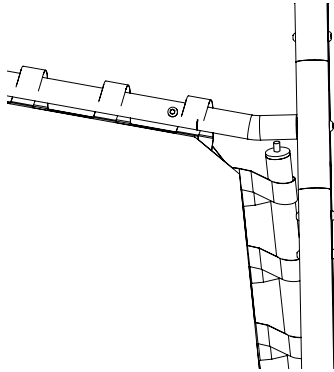

- B. Push the pins on the bottoms of the Side Tubes through the holes in the corner of the L-Tubes.

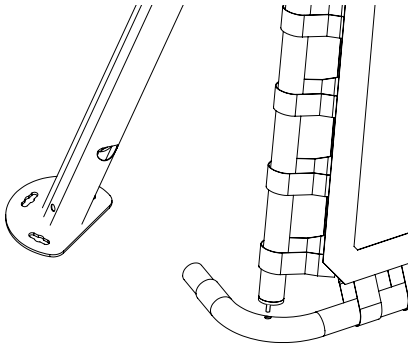

STEP | 6

Insert the ends of the L-Tubes into the holes in the Leg Tubes on your Vuly Max. Secure with bolts.

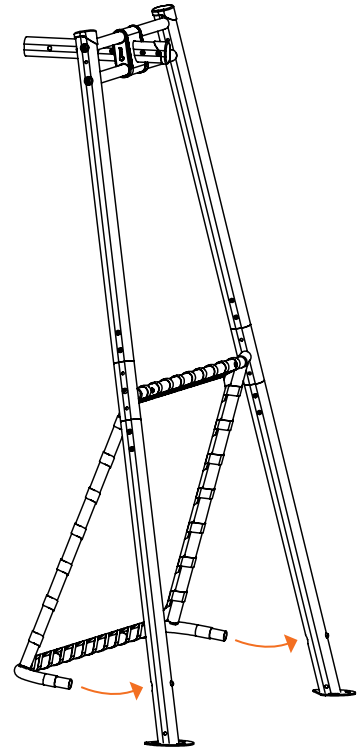

CONGRATULATIONS!

You have attached the Soccer Goal to your Vuly Max.

DISCLAIMER

ATTENTION!

Safety information, installation and use instructions. Read prior to installing and using the swings.

See [VulyPlay.com/support](https://www.vulyplay.com/support) for any updates to these instructions.

WARNING!

- Minimum user age - 6 years. Only for domestic and outdoor use.
- Maximum user weight per swing station - 80 kg (175 lb) [65 kg (132 lb) on Spin Swing].
- Maximum combined user weight per swing set section - 150 kg (330 lb).
- Adult assembly required. Adult supervision required at all times.
- Ensure that the Swing Set is secured with anchors or bolts before use.



ADULT SUPERVISION IS REQUIRED AT ALL TIMES WHILST EQUIPMENT IS IN USE.
VULY CARES ABOUT SAFETY.